

**KONRAD
TOOLS**

www.konradtools.com



Milling Catalogue

Fräsen Katalog

2	Inserts Wendeschneidplatten <ul style="list-style-type: none"> Grade Overview Sortenübersicht 5 Grade Description Milling Sortenbeschreibung Fräsen 6 Designation System Bezeichnungssystem 10 ISO Indexable Insert Designation ISO Wendeschneidplattenbezeichnung 12 Indexable Inserts Wendeschneidplatten 14 	19	Milling Cutters Fräswerkzeuge <ul style="list-style-type: none"> Shoulder Milling Cutters Eckfräser 21 Face Milling Cutters 75° Planfräser 75° 30 Face Milling Cutters 45° Planfräser 45° 31 Helical Roughing End Mill Schaftschruppfräser 34 Cutting Speed Recommendations Schnittgeschwindigkeit 36 Cutting parameters universal grade Schnittwerte universal sorte 38 Technical Hints Technische Hinweise 49 	57	Minimill Minifräsen <ul style="list-style-type: none"> Milling Cut for Chamfering 30°, 45°, 60° Fräser zum Fasen 30°, 45°, 60° 59 Milling Cutters for Chamfering 45° Fräser zum Fasen 45° 59 Milling Cutters for Chamfering-Flaring 10° to 80° Fasenfräser, Winkelverstellbar von 10° bis 80° 60 T Slot Milling Cutter Fräser für T-nuten 61 Drilling Endmill Bohrnutfräser 62 Spot Facing and Boring Milling Cutters Senkfräserund Ausbohrer 63 180° Spot-Facing End Mills Senkfräser 180° 64 180° Back Facing Milling Cutters Rückwärtssenker 180° 65 Adjustement Boring Bars Einstellbare Feinbohrstangen 66 Chamfering Milling Cutters Fasenfräser 67
69	Solid Carbide Tools Vollhartmetall Werkzeuge <ul style="list-style-type: none"> Solid Carbide Milling Cutters Vollhartmetall Fräswerkzeuge 71 Solid Carbide Drills Vollhartmetall-Bohrer 86 	96	Technical Hints Technische Hinweise <ul style="list-style-type: none"> Ramping Rampe eintauchen 96 Formulas Formeln 96 Calculation of Approach Angle ϕ_s Berechnung des Eingriffswinkels ϕ_s 97 	98	Attachment Anhang <ul style="list-style-type: none"> Dimensions, units and application formulas Maße, Einheiten, Anwendungsformeln 98 Solutions of Problems in Milling Lösungen von Problemen beim Fräsen 99 Material Comparison Chart Werkstoffe – Vergleichstabelle 100

Inserts

Wendeschneidplatten



<p>5</p> <p>Grade Overview Sortenübersicht</p>	<p>6</p> <p>Grade Description Milling Sortenbeschreibung Fräsen</p>	<p>10</p> <p>Designation System Bezeichnungssystem</p> <p>Cutter designation system Fräserbezeichnung 10</p> <p>Cutting materials, designation system Schneidstoffsorten, Bezeichnung 11</p> <p>Symbols for milling operations Symbolerklärung für Fräsoperationen 11</p>
<p>12</p> <p>ISO Indexable Insert Designation ISO Wendeschneidplattenbezeichnung</p>	<p>14</p> <p>Indexable Inserts Wendeschneidplatten</p> <p>APKT ...; LNMX ...; ONMU ... 14</p> <p>SDHT ...; SEGT, SEHT, SEKT ...; SEKN, SEKR ... 15</p> <p>SNEX, SNMX ...; SPMT ...; WNEU ... 16</p> <p>CCMT ...; SCMT ...; TCMT ... 17</p>	

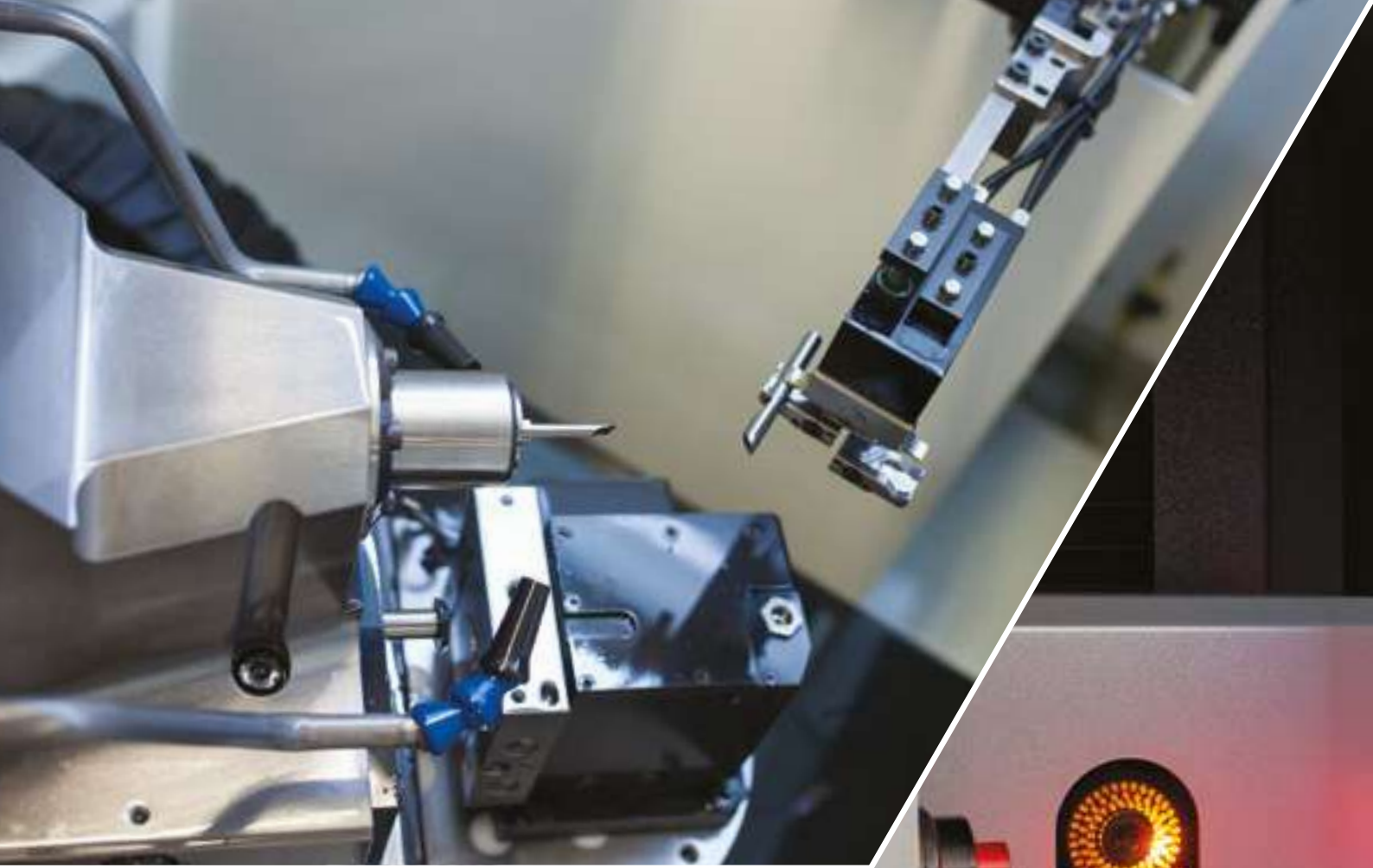

Grade Sorte	ISO ISO	Application Range Anwendungsbereich	Material Group Werkstoffgruppe						Application Bearbeitungsverfahren				Color guide for inserts depending on coating Farbliche Darstellung der WSP je nach Beschichtung	
			P Steel Stahl	M Stainless Rostfrei	K Grey cast iron Schmelzguss	N Nonferrous metals Nichtferre Metalle	S High temperature materials Hochwarmfest	H Hard materials Harte Werkstoffe	T Turning Drehen	M Milling Fräsen	D Drilling Bohren	S Threading Gewindebearbeitung		
A6M-A2	HC-P30													
A4M-A1	HC-P20													
A5M-B1	HC-P25													
	HC-M25													
	HC-K25													
A6M-C1	HC-P30													
A7M-D1	HC-P35													
	HC-M35													
A8M-E1	HC-P40													
	HC-M45													
B7M-F1	HC-M35													
	HC-S35													
B8M-G1	HC-M40													
C3M-H1	HC-K15													
C4M-I1	HC-K20													
	HC-P10													
D1M-B2	HW-P05													
D2M-J1	HC-N10													
	HC-S20													
D3M-K1	HC-N15													
D2M-K1	HW-N10													

Application peak
Anwendungsschwerpunkt

Full range to ISO 513
Gesamtbereich nach ISO 513

■ Main application
Hauptanwendung

□ Further applications
Weitere Anwendung

● Standard grade
Standardsorte

Grades for milling inserts

- A6M-A2 (HC-P30)

Super universal grade for milling steel, stainless steel, cast iron, non ferrous material, super alloys and hard materials.

- A4M-A1 (HC-P20) TERAspeed 2.0

Harder alternative to the A5M-B1 grade, with HR-CVD; high resistance to abrasive wear. Perfectly suited for face milling of steel materials at higher cutting speed under stable conditions.

- A5M-B1 (HC-P25/M25) Goldlox

Multi purpose grade for milling unalloyed, low alloyed, high alloyed and stainless steel. The PVD coated grade is especially suitable for high cutting speeds on dry / wet machining under stable conditions.

- A6M-C1 (HC-P30) TERAspeed 2.0

Universal steel milling grade especially for plain milling. The very tough carbide substrate guarantees high machining security on a wide range of steel materials. A modern HR-CVD coating ensures economic dry machining on high cutting speeds.

- A7M-D1 (HC-P35/M35) Goldlox

Universal steel milling grade in combination with 90° approach angle. A PVD layer and a tough carbide grade for milling of the most usual steel qualities. Especially good suitable for dry milling at low to medium cutting speeds under difficult conditions.

- A8M-E1 (HC-P40/M45) Goldlox

A PVD-layer plus heavy-duty carbide grade for roughing of mainly tool, heat-treated and case-hardened steel, as well as austenitic, stainless materials.

- B7M-F1 (HC-M35/S35)

Wear-resistant PVD coating, fine-grain grade for machining stainless and austenitic stainless materials; suitable for wet and dry machining.

- B8M-G1 (HC-M40)

Extremely tough, relative fine grained carbide substrate with thin, smooth PVD coating. Ideal grade for milling of austenitic stainless steels and materials from the Duplex group with low to medium cutting speeds. Also for wet machining, although minimum coolant supply is recommended.

- C3M-H1 (HC-K15) TERAspeed 2.0

Selected raw materials for optimised K15 carbide substrate with a particularly hard and wear-resistant HR-CVD multi-layer coating. Ideal for dry machining of grey cast iron (GJL), spheroidal graphite cast iron (GJS), tempered cast iron and alloyed cast iron.

- C4M-I1 (HC-K20/P10)

Tough K20 substrate and a thick PVD coating for the machining of cast materials. Also suited as finishing grade for steel cutting and the machining of cold work steels of 54 HRC.

- D1M-B2 (HW-P05)

Universal grade for non-ferrous material and super alloys.

- D2M-J1 (HC-N10/S20)

Ideal grade for machining aluminium materials and other non ferrous metals. Due to the ultra-thin PVD TiAlN layer perfectly well suited for finishing stainless steels and grey cast iron.

- D3M-K1 (HC-N15)

Grade for aluminium machining. With our new „TiBN“ CVD coating. The layer has not only a big layer hardness but also a smooth surface.

- D2M-K1 (HW-N10)

Uncoated grade for the machining of non ferrous metals and aluminium.

Sorte für fräsen Wendeschneidplatten

- A6M-A2 (HC-P30)

Universelle sorte für Fräsen Stahl, rostfreien Stahl und Guss.

- A4M-A1 (HC-P20) TERASpeed 2.0

Härtere Alternative mit HR-CVD zur Sorte A5M-B1, mit hohem Widerstand gegen Abrasivverschleiß. Ausgezeichnet geeignet für die Planfräsbearbeitung von Stahlmaterialien mit erhöhter Schnittgeschwindigkeit, unter stabilen Bedingungen.

- A5M-B1 (HC-P25/M25) Goldlox

Mehrbereichssorte zum Fräsen von unlegiertem, niedrig legiertem, hoch legiertem und rostfreiem Stahl. Die PVD beschichtete Sorte eignet sich besonders für hohe Schnittgeschwindigkeiten bei der Trockenbearbeitung / Nassbearbeitung unter stabilen Bedingungen.

- A6M-C1 (HC-P30) TERASpeed 2.0

Universelle Stahlfräsorte vor allem zum Planfräsen. Hohe Bearbeitungssicherheit auf einem breiten Stahlwerkstoffspektrum wird durch das besonders zähe Hartmetallsubstrat garantiert. Eine moderne HR-CVD Beschichtung bietet wirtschaftliche Trockenbearbeitung bei hohen Schnittgeschwindigkeiten.

- A7M-D1 (HC-P35/M35) Goldlox

Universelle Stahlfräsorte in Kombination mit Anstellwinkel 90°. Eine PVD Schicht und eine zähe Hartmetallsorte zum Fräsen von den gängigen Stahlsorten. Besonders gut geeignet zum Trockenfräsen bei niedrigen bis mittleren Schnittgeschwindigkeiten unter schwierigen Bedingungen.

- A8M-E1 (HC-P40/M45) Goldlox

Eine PVD Schicht und zähe Hartmetallsorte zum Schruppen von vor allem Werkzeug-, Vergütungs-, Einsatzstählen und austenitisch, rostfreien Materialien.

- B7M-F1 (HC-M35/S35)

Verschleißfeste PVD-Beschichtung, Feinkornsorte zur Bearbeitung von rostfreien und austenitisch rostfreien Materialien, zur Nass- und Trockenbearbeitung geeignet.

- B8M-G1 (HC-M40)

Extrem zähes, relativ feinkörniges Hartmetallsubstrat mit dünner, glatter PVD Beschichtung. Ideale Sorte zum Fräsen von austenitisch rostfreien Stählen und Werkstoffen aus der Duplexgruppe mit niedrigen bis mittleren Schnittgeschwindigkeiten. Auch für die Nassbearbeitung, jedoch wird Minimalmengenschmierung empfohlen.

- C3M-H1 (HC-K15) TERASpeed 2.0

Ausgesuchte Rohstoffe für ein optimiertes K15-Hartmetallsubstrat mit einer extrem harten und verschleißfesten HR-CVD Mehrlagen-beschichtung. Ideal geeignet für die Trockenbearbeitung von Grauguss (GJL), Kugelgraphitguss (GJS), Temperguss und legiertem Guss.

- C4M-I1 (HC-K20/P10)

Zähes K20 – Substrat und eine dicke PVD-Beschichtung für die Bearbeitung von Gussmaterialien. Auch als Schlichtsorte für die Stahlzerspanung und für die Bearbeitung von Kaltarbeitsstählen härter als 54 HRC geeignet.

- D1M-B2 (HW-P05)

Universelle sorte für NE-Metallen materialien.

- D2M-J1 (HC-N10/S20)

Ideale Sorte für die Bearbeitung von Aluminiumwerkstoffen und weiteren NE-Metallen. Durch eine hauchdünne PVD TiAlN-Schicht ebenfalls hervorragend für die Schlichtzerspanung von rostfreien Stählen und Grauguss geeignet.

- D3M-K1 (HC-N15)

Sorte für die Aluminiumbearbeitung, mit unserer neuen "TiBN" CVD Beschichtung. Die Schicht besitzt neben einer hohen Schichthärte auch eine sehr glatte Oberfläche.

- D2M-K1 (HW-N10)

Unbeschichtete Sorte für die Bearbeitung von NE-Metallen sowie Aluminium.

Grades for CCMT ..., SCMT ... and TCMT ..., coated

- HS A31-A1 (HC-P15, HC-K15)

Wear resistant steel grade for not interrupted cut for high cutting speeds up to 300 m/min. As secondary application also for machining of cast iron.

- A51-B1 (HC-P25, HC-M25)

(Universal turning grade)

Main grade for machining steel materials and easily machinable stainless steels at medium cutting speeds, including interrupted cutting work. This general purpose grade is characterised by the properties of high durability and excellent toughness across a wide range of applications.

- IC A81-C1 (HC-P40, HC-M40)

The IC A81-C1 Steeltec steel turning grade guarantees maximum performance in heavy interrupted cutting thanks to the combination of an extremely tough carbide with the "Nanolock yellow MT-CVD layer".

- B41-D1 (HC-M20, HC-S20)

Turning grade for machining of austenitic materials in the high cutting speed area of 170–220 m/min.

- B51-E1 (HC-M25, HC-P30)

Turning grade for austenitic stainless steels in medium and high cutting speed area.

- B81-F1 (HC-M40, HC-P40)

Very tough stainless grade for low cutting speeds suitable, also as alternative applicable on steel.

- B71-G1 (HC-M35, HC-P35)

Main grade for turning of austenitic stainless steels at medium cutting speeds. Applicable also for super alloys.

- HS C31-J1 (HC-K15)

Cast iron turning grade for the area K15. Optimal for machining GG and GGG materials. Possible cutting speeds for GG up to 400 m/min.

Grade for CCMT ..., SCMT ... and TCMT ..., uncoated

- C21-Q1 (K05-K15)

For turning chilled iron casting, grey cast iron with spheroidal graphite and alloyed grey cast iron as well as for aluminium and aluminium alloys. Turning high grade and hardened steels, also for austenitic manganese steels.

Sorten für CCMT ..., SCMT ... und TCMT ..., beschichtet

- HS A31-A1 (HC-P15, HC-K15)
Verschleißfeste Stahlsorte für den nichtunterbrochenen Schnitt für hohe Schnittgeschwindigkeiten bis 300 m/min. Als Nebenanwendung auch für die Bearbeitung von Guss geeignet.
- A51-B1 (HC-P25, HC-M25)
(Universelle Drehsorte)
Hauptsorte zum Drehen von Stahlwerkstoffen und leicht zerspanbarem rostbeständigem Stahl bei mittleren Schnittgeschwindigkeiten, auch bei unterbrochenem Schnitt. Diese Mehrbereichssorte zeichnet sich durch hohe Verschleiß-festigkeit und ausgezeichnete Zähigkeitseigenschaften in einem breiten Einsatzspektrum aus.
- IC A81-C1 (HC-P40, HC-M40)
Die Stahldrehsorte Steeltec LC240F gewährleistet durch das Zusammenspiel eines extrem zähen Hartmetalls mit der „Nanolock gelb MT-CVD-Schicht“ höchste Performance im stark unterbrochenen Schnitt.
- B41-D1 (HC-M20, HC-S20)
Drehsorte für die Bearbeitung von austenitischen Werkstoffen im hohen Schnittgeschwindigkeitsbereich von 170–220 m/min.
- B51-E1 (HC-M25, HC-P30)
Drehsorte für austenitische rostfreie Stähle im mittleren bis hohen Schnittgeschwindigkeitsbereich.
- B81-F1 (HC-M40, HC-P40)
Sehr zähe Rostfreisorte für niedrige Schnittgeschwindigkeiten geeignet, auch als Alternative auf Stahl einsetzbar.
- B71-G1 (HC-M35, HC-P35)
Hauptsorte zu Drehen von austenitischen rostfreien Stählen bei mittleren Schnittgeschwindigkeiten. Erweiterte Anwendung für Superlegierungen.
- HS C31-J1 (HC-K15)
Gussdrehsorte im Bereich K15, optimal für die Bearbeitung von GG- und GGG- Materialien. Schnittgeschwindigkeiten bis 400 m/min. auf GG möglich.

Sorte für CCMT ..., SCMT ... und TCMT ..., unbeschichtet

- C21-Q1 (K05-K15)
Zum Drehen von Hartguss, Grauguss mit Kugelgraphit und legiertem Grauguss sowie für Aluminium und Aluminiumlegierungen. Drehen von hochvergüteten und gehärteten Stählen, auch für Manganhartstähle.

Cutter designation system

Fräserbezeichnung

SE	1	050	(L)	02	45	06	0	0	1
----	---	-----	-----	----	----	----	---	---	---

Type Typ	Model Modell	Diameter Durchmesser [mm]		Z	Angle Winkel [°]	Insert size Wendeschneid- platten Größe	Internal code Intern Code
SE Shoulders End mill Schaft-Eckfräser		050 080 150 230	DC Different Construction Andere Konstruktion	02 03 06 08	30 45 60 90	06 08 09 10 11 15 16 22 27 33 44	
SS Shoulders Shell Aufsteckfräser			NC No Cooling Ohne Kühlung				
FE Face End mill Plan- Schaftfräser			L Long Lange				
FS Face Shell Planfräser			F Finishing Schlicht				
HE Helical End mill Schrauben- Schaftschrupp- fräser							
HS Helical Shell Schrauben- Aufsteckfräser							
CH Chamfering Fasfräser							
TS T-slot T-Nuten							
DE Drilling End mill Bohrnutfräser							
SF Spot Facing Senkungsfräser							
AB Adjust Bar Feinbohrstangen							

Cutting materials, designation system

Schneidstoffsorten, Bezeichnung

MF		HF		B	4	M	A	1	1
CHIP BREAKER SPANFORMER			INSERT WEDNESCHNEIDEPLATTEN						
Operation Betrieb	Special sign Sonderzeichen		Grade Sorte			Internal code Intern Code			
R Roughing Schruppen	AL Aluminium Aluminium		P = A	10 = 2	M Milling Fräsen				
MR Medium Roughing Mittlere- Schruppen	HF High Feed Hoch Vorschub		M = B	15 = 3					
M Medium Mittlere	CH Chipbreaker Spanformer		K = C	20 = 4					
MF Medium Finishing Mittlere-Schlichten	W Wiper Wiper		N = D	25 = 5					
F Finishing Schlichten			S = E	30 = 6					
			H = F	35 = 7					
			Cermet = G	40 = 8					
			CBN = H	45 = 9					
			PCD = I	50 = 0					

Symbols for milling operations

Symbolerklärung für Fräsoperationen

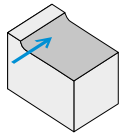

Face milling
Planfräsen

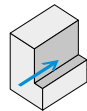

Trimming
Besäumen

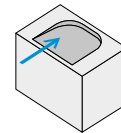

Linear ramping
Rampe eintauchen

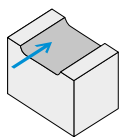

Pocket milling
Gassenfräsen

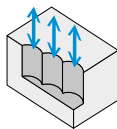

Plunge milling
Tauchfräsen

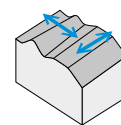

Copy milling
Kopierfräsen

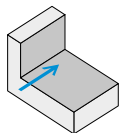

Edge milling
Eckfräsen

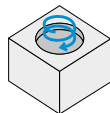

Helical ramping
Zirkularfräsen

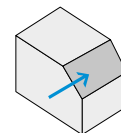

Chamfering
Fasen

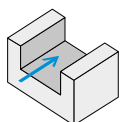

Slot milling
Nutfräsen

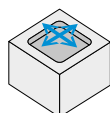

Pocketing
Taschenfräsen

S
Insert shape
Grundform

A		85°
B		82°
C		80°
D		55°
E		75°
H		120°
K		55°
L		90°
M		86°
O		135°
P		108°
R		-
S		90°
T		60°
V		35°
W		80°

The corner angle is in the case of not equiangular basic forms always the smaller angle. Der Eckenwinkel ist bei ungleichwinkligen Grundformen immer der kleinere Winkel.

N
Clearance angle
Freiwinkel

A	3°
B	5°
C	7°
D	15°
E	20°
F	25°
G	30°
N	0°
P	11°
O	

Normal clearance angles, which require a special description. Normalfreiwinkel, die eine besondere Beschreibung erfordern.

M
Tolerances
Toleranzen

	m	s	d
A	±0,005	±0,025	±0,025
C	±0,013	±0,025	±0,025
E	±0,025	±0,025	±0,025
F	±0,005	±0,025	±0,013
G	±0,025	±0,130	±0,025
H	±0,013	±0,025	±0,013
J	±0,005	±0,025	See Siehe Tab. 1
K	±0,013	±0,025	See Siehe Tab. 1
L	±0,025	±0,025	See Siehe Tab. 1
M	See Siehe Tab. 2	±0,130	See Siehe Tab. 1
N	See Siehe Tab. 2	±0,025	See Siehe Tab. 1
U	See Siehe Tab. 2	±0,130	See Siehe Tab. 1

Tab. 1 d

d over – up to über – bis	J, K, L, M	U
3,9 – 10,0	±0,05	±0,08
10,0 – 15,0	±0,08	±0,13
15,0 – 20,0	±0,10	±0,18
20,0 – 26,0	±0,13	±0,25
26,0 – 32,0	±0,15	±0,25

Tab. 2 m

d over – up to über – bis	M, N	U
3,9 – 10,0	±0,08	±0,13
10,0 – 15,0	±0,13	±0,20
15,0 – 20,0	±0,15	±0,27
20,0 – 26,0	±0,18	±0,38
26,0 – 32,0	±0,20	±0,38

Corner rounding uneven number of sides
Eckenrundung, ungerade Seitenzahl

Corner rounding, even number of sides
Eckenrundung, gerade Seitenzahl

Chamfered inserts
Fasenplatten

X
Chip breaker, fixation
Spanformer, Befestigung

A	
B	
C	
F	
G	
H	
J	
M	
N	
Q	
R	
T	
U	
W	

X With special feature according to drawing
Mit Besonderheit nach Zeichnung

() Cone angle for screw
Kegelwinkel für Schraube

12
Cutting edge length
Schneidenlänge

	l
06	6,350
07	7,938
09	9,525
11	11,000
12	12,700
15	15,875
16	16,500
19	19,050
22	22,000
25	25,400
31	31,750
38	38,100

06
Thickness
Dicke

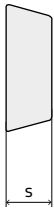

	s
02	2,38
03	3,18
T3	3,97
04	4,76
05	5,56
06	6,35
07	7,94
08	8,00
09	9,52

Dimensions in mm
Abmessungen in mm

AN
Cutting edge corner
Schneidenecke

For radius inserts
Für Radiusplatten

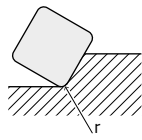

	Corner radius Eckradius r
00	sharp-edged scharfkantig
02	0,2
04	0,4
08	0,8
12	1,2
16	1,6
20	2,0
	etc. usw.

For chamfered inserts face milling
Für Fasenplatten
Planschneiden

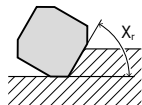

	Approach angle Anstellwinkel Xr
A	45°
D	60°
E	75°
F	85°
P	90°
Z	Special Sonder
	Clearance angle of face milling edge Freiwinkel der Planschneide αn
A	3°
B	5°
C	7°
D	15°
E	20°
F	25°
G	30°
N	0°
P	11°
Z	Special Sonder

MO Round insert metric
Rundwende platte
metrisch

OO Round insert Inch
Rundwende platte
Zoll

S
Cutting edge type¹⁾
Schneidenaus-
führung¹⁾

Sharp-edged
Scharfkantig

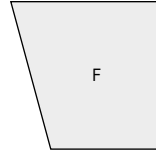

Rounded
Gerundet

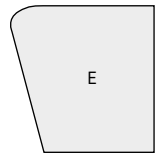

Chamfered
Gefast

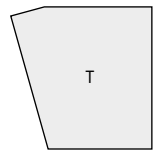

Chamfered and
rounded Gefast
und gerundet

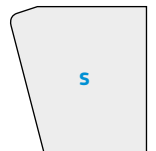

Double chamfered
Doppelgefast

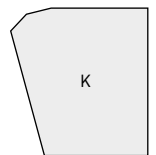

Double chamfered
and rounded
Doppelgefast und
gerundet

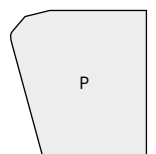

N
Direction of cut¹⁾
Schneidrichtung¹⁾

R

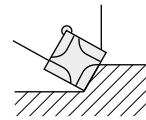

Right hand cut only
Nur rechtsschneidend

L

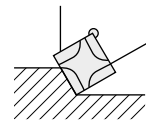

Left hand cut only
Nur linksschneidend

N

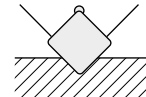

Right and left hand cut
Rechts- und links-
schneidend

¹⁾ The use of these
reference letters is
optional.
Die Anwendung
dieser Kennbuch-
staben ist freigestellt.

MM1
Geometry
Geometrie

MM1	Geometry for medium steel machining Geometrie für mittlere Stahlbearbeitung
M-HF1	High feed geometry for medium steel machining Hochvorschub, f. mittlere Stahlbearbeitung
R1	Geometry for roughing of steel Geometrie für Schruppbearbeitung – Stahl
R-HF1	High feed geometry for roughing of steel Hochvorschub, für Schrubbearbeitung – Stahl
R-CH	Geometry for roughing of steel with chip breaker Geom. für Schruppbearb. Stahl mit Spanteiler
MM2	Geometry for medium stainless machining Geometrie für mittlere Bearb. Rostfrei
M-HF2	High feed geometry for medium stainless machining Hochvorschub Geometrie für mittlere Bearb. Rostfrei
M3	Geometry for medium cast iron machining Geometrie für mittlere Gussbearbeitung
R2	Geometry for roughing of cast iron Geometrie für Schruppbearbeitung Guss
R-HF2	High feed geometry for medium roughing of cast iron Hochvorschub Geometrie für Schruppbearb. Guss
M-W	Geometry for wide finishing (Wiper) Geometrie für Breitschichten (Wiper)
M-AL	Geometry for aluminium Geometrie für Aluminium
M1	Geometry for steel machining Geometrie für Bearbeitung Stahl

Example Beispiel

#	S	N	M	X	12	06	AN	S	N-MM1
1									
2									
3									
4									
5									
6									
7									
8									
9									
10									

1	Basic form Grundform	square quadratisch
2	Clearance angle Freiwinkel	0°
3	Tolerances Toleranzen	m ± 0,013 s ± 0,025 d ± 0,13
4	Fixing cutting face Befestigung Spanfläche	with special feature according to drawing mit Besonderheit nach Zeichnung
5	Length of cutting edge Schneidenslänge	12,7
6	Thickness Dicke	5,56
7	Cutting edge corner Schneidenecke	45° chamfer 45° Fase
8	Cutting edge Schneidenkante	rounded gerundet
9	Direction of cut Schneidrichtung	right- and lefthand rechts- und linksschneidend
10	Internal designation Interne Bezeichnung	TR = Geometry Spanflächentopographie

Indexable insert designation
Wendeschneidplattenbezeichnung
ISO 1832.2 DIN 4987

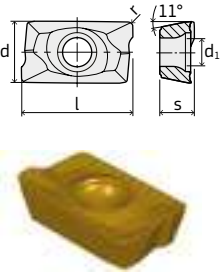
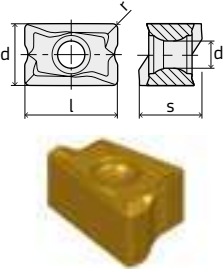
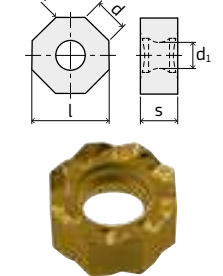
	Ordering Code Bestellbezeichnung	l	d	s	d ₁	r	Cutting materials Schneidstoffsorten																		
							A6M-A2	A4M-A1	A5M-B1	A6M-C1	A7M-D1	A8M-E1	B7M-F1	B8M-G1	C3M-H1	C4M-I1	D1M-B2	D2M-J1	D2M-K1						
APKT ... 	APKT 060204 PDTR-M	6,00	3,66	2,16	2,06	0,40	●																		
	APKT 1003 PDSR-M1	10,00	6,70	3,50	2,80	0,50			●	●	●					●	●								
	APKT 1003 PDSR-M2	10,00	6,70	3,50	2,80	0,50								●											
	APKT 1003 PDTR-M	10,39		3,53		0,80	●																		
	APKT 100304 PDTR-M	10,39		3,53		0,40	●																		
	APKT 100304 SR-MM2	10,00	6,70	3,50	2,80	0,50			●		●														
	APKT 100304 SR-MM3	10,00	6,70	3,50	2,80	0,50								●											
	APKT 100304 SR-R3	10,00	6,70	3,50	2,80	0,50										●	●								
	APKT 100304 SR-RR2	10,00	6,70	3,50	2,80	0,50				●	●	●													
	APKT 100312 PDTR-M	10,39		3,53		1,20	●																		
	APKT 100316 PDTR-M	10,39		3,53		1,60	●																		
	APKT 100332 PDTR-M	10,39		3,53		4,00	●																		
	APKT 100340 PDTR-M	10,39		3,53		4,00	●																		
	APKT 1604 PDSR-M1	16,00	9,52	5,26	4,50	0,80			●	●	●						●								
	APKT 1604 PDSR-M2	16,00	9,52	5,26	4,50	0,80										●									
	APKT 1604 PDTR-M	15,30		4,76		0,80	●																		
	APKT 160408 SR-MM2	16,00	9,52	5,26	4,50	0,80			●		●														
	APKT 160408 SR-MM3	16,00	9,52	5,26	4,50	0,80										●									
	APKT 160408 SR-R3	16,00	9,52	5,26	4,50	0,80												●							
	APKT 160408 SR-RR2	16,00	9,52	5,26	4,50	0,80				●	●	●													
	APKT 160416 SR-M1	16,00	9,52	5,26	4,50	0,80				●															
	APKT 160424 ER-M	15,30		4,76		2,40	●																		
	APKT 160424 PDTR-M	15,30		4,76		2,40	●																		
	APKT 160424 SR-M1	16,00	9,52	5,26	4,50	0,80				●															
APKT 160432 SR-M1	16,00	9,52	5,26	4,50	0,80				●																
LNMX ... 	LNMX 100605 SR-R1	10,00	6,60	6,35	2,80	0,50			●		●	●													
	LNMX 100605 SR-R2	10,00	6,60	6,35	2,80	0,50											●	●							
	LNMX 151008 SR-R1	15,00	9,52	10,00	4,50	0,80			●		●	●													
	LNMX 151008 SR-R2	15,00	9,52	10,00	4,50	0,80											●	●							
ONMU ... 	ONMU 1205 ANN-M	12,70	4,80	6,00	5,20	0,50		●		●													●		

Order Example: 10 pieces APKT 1003 PDSR-M1 A5M-B1
 Bestellbeispiel: 10 Stück APKT 1003 PDSR-M1 A5M-B1

Colours of the original indexable inserts may deviate from the illustration!
 Farbliche Abbildung der WSP müssen nicht dem Original entsprechen!

● Available from stock Verfügbar ab Lager

Description of grades page Sortenbeschreibung Seite 5-7

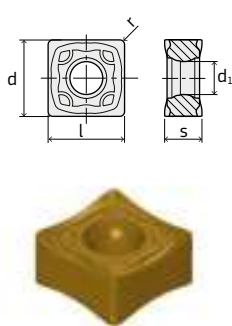
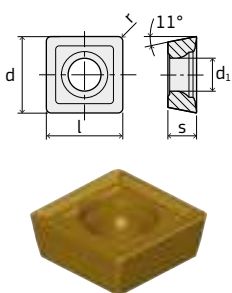
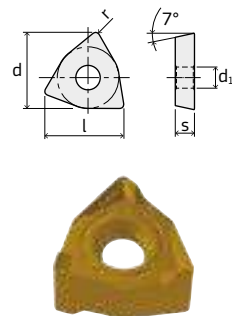
	Ordering Code Bestellbezeichnung	l	d	s	d ₁	r	Cutting materials Schneidstoffsorten													
							A6M-A2	A4M-A1	A5M-B1	A6M-C1	A7M-D1	A8M-E1	B7M-F1	B8M-G1	C3M-H1	C4M-I1	D1M-B2	D2M-J1	D2M-K1	
SNEX, SNMX ... 	SNEX 1206-M-W	12,70	12,70	6,35	5,20	-							●							
	SNMX 1206 ANSN-MM1	12,70	12,70	6,35	5,20	-	●	●	●	●										
	SNMX 1206 ANSN-MM2	12,70	12,70	6,35	5,20	-						●	●							
	SNMX 1206 ANSN-M3	12,70	12,70	6,35	5,20	-								●	●					
	SNMX 120608 SN-MM1	12,70	12,70	6,35	5,20	-			●	●										
	SNMX 120608 SN-MM2	12,70	12,70	6,35	5,20	-						●								
	SNMX 120608 SN-M3	12,70	12,70	6,35	5,20	-								●	●					
	SNMX 120612 SN-MM1	12,70	12,70	6,35	5,20	-			●	●					●	●				
	SNMX 120612 SN-M3	12,70	12,70	6,35	5,20	-									●	●				
SPMT ... 	SPMT 060304 TN-M	6,35		3,20		0,40	●													
	SPMT 09T308 TN-M	9,53		3,71		0,80	●													
	SPMT 120408 TN-M	13,29		4,80		0,80	●													
WNEU ... 	WNEU 080608-M	7,50	12,50	6,56	0,50	0,80	●		●										●	

Order Example: 10 pieces SNMX 1206 ANSN-MM1 A4M-A1
Bestellbeispiel: 10 Stück APKT 1003 PDSR-M1 A5M-B1

Colours of the original indexable inserts may deviate from the illustration!
Farbliche Abbildung der WSP müssen nicht dem Original entsprechen!

● Available from stock Verfügbar ab Lager

Description of grades page Sortenbeschreibung Seite 5-7



Milling Cutters

Fräswerkzeuge

<p>21</p> <p>Shoulder Milling Cutters Eckfräser</p> <p>SE1-... 21 SE2-... 21 SS1-... 22 SS2-... 22 SE3-... 23 SE5-... 26 SS5-... 24 SE6-... 25 SE35-... 26 SS36-... 26 SS37-... 27 SS6-... 28 SE7-... 28 SS7-... 29 SS8-... 29</p>	<p>30</p> <p>Face Milling Cutters 75° Planfräser 75°</p> <p>SE9-... 30 SS9-... 30 SS10-... 30</p>	<p>31</p> <p>Face Milling Cutters 45° Planfräser 45°</p> <p>SS11-... 31 SE12-... 32 SS12-... 32 SS13-... 33 SS16-... 33</p>
<p>34</p> <p>Helical Roughing End Mill Schaftschruppfräser</p> <p>SE17-... 34 SS17-... 34 SE18-... 35 SS18-... 35</p>	<p>36</p> <p>Cutting Speed Recommendations Schnittgeschwindigkeit</p> <p>Cutting Speed Recommendations for Milling Cutter 45° and 90° Schnittgeschwindigkeit für Fräser 45° und 90° 36</p>	<p>38</p> <p>Cutting parameters universal grade Schnittwerte universal sorte</p> <p>APKT 1003 PDTR-M A6M-A2 38 APKT 100304 PDTR-M A6M-A2 39 APKT 100312 PDTR-M A6M-A2, APKT 100316 PDTR-M A6M-A2 40 APKT 100332 PDTR-M A6M-A2 41 APKT 100340 PDTR-M A6M-A2 42 APKT 1604 PDTR-M A6M-A2 43 APKT 160416 PDTR-M A6M-A2 44 SEKN 1203 AFTN-M A6M-A2, SEKR 1203 AFTN-M A6M-A2, SEKT 1203 AFTN-M A6M-A2 45 SPMT 060304TN-M A6M-A2 46 SPMT 09T308 TN-M A6M-A2 47 SPMT 120408 TN-M A6M-A2 48 SEGT 1204 AFEN-M A6M-A2 48</p>
<p>49</p> <p>Technical Hints Technische Hinweise</p> <p>Cutting data recommendations Schnittwertempfehlungen für Drehen 49</p>		

SE1-...

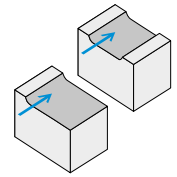
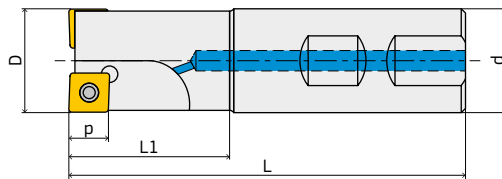

Ordering Code Bestellbezeichnung	Dimensions [mm] Abmessungen [mm]						Weight [kg] Gewicht [kg]	Spare Parts Ersatzteile		
	D	d	L	L1	p	z				
SE1-010.01.89.06.2-0	10	16	80	24	6	1	0,100	SPMT 060304 ...	VT25	BT08
SE1-012.01.89.06.2-0	12	16	80	24	6	1	0,120			
SE1-016.02.89.06.2-0	16	16	85	25	6	2	0,130			
SE1-020.03.89.06.2-0	20	20	90	25	6	3	0,200			
SE1-025.04.89.06.2-0	25	25	95	25	6	4	0,340			
SE1-032.05.89.06.2-0	32	25	95	26	6	5	0,380			
Long models Lange Ausführung										
SE1-016L.02.89.06.2-0	16	16	150	100	6	2	0,210	SPMT 060304 ...	VT25	BT08
SE1-020L.03.89.06.2-0	20	20	150	100	6	3	0,330			
SE1-025L.04.89.06.2-0	25	20	150	25	6	4	0,350			
SE1-032L.05.89.06.2-0	32	25	150	30	6	5	0,560			

SE2-...

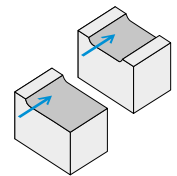
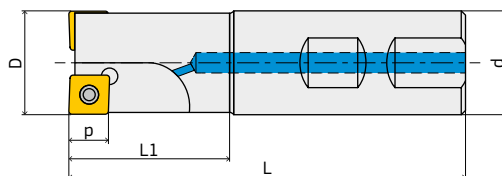



Ordering Code Bestellbezeichnung	Dimensions [mm] Abmessungen [mm]						Weight [kg] Gewicht [kg]	Spare Parts Ersatzteile		
	D	d	L	L1	p	z				
SE2-025.02.89.09.2-0	25	25	100	44	9	2	0,380	SPMT 09T308 ...	VT355	BT15
SE2-032.03.89.09.2-0	32	32	110	50	9	3	0,640			
SE2-040.04.89.09.2-0	40	32	115	45	9	4	0,760			

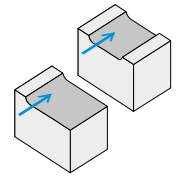
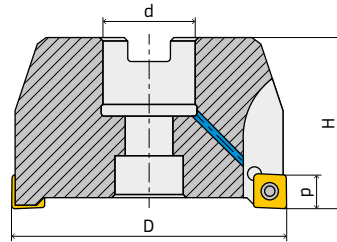

Without coolant Trockenbearbeitung

With coolant Nassbearbeitung

SS1-...

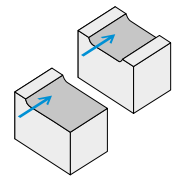
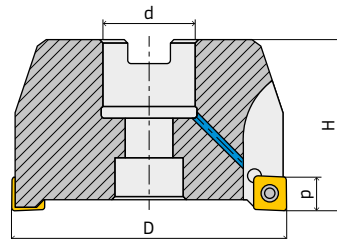
Ordering Code Bestellbezeichnung	Dimensions [mm] Abmessungen [mm]						Weight [kg] Gewicht [kg]	Spare Parts Ersatzteile		
	D	d	H	p	z					
SS1-040.06.89.06.2-0	40	16	40	6	6	0,270	SPMT 060304 ...	VT25	BT08	
SS1-050.07.89.06.2-0	50	22	40	6	7	0,430				
SS1-063.08.89.06.2-0	63	22	40	6	8	0,610				

SS2-...

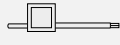
Ordering Code Bestellbezeichnung	Dimensions [mm] Abmessungen [mm]						Weight [kg] Gewicht [kg]	Spare Parts Ersatzteile		
	D	d	H	p	z					
SS2-040.04.89.09.2-0	40	16	40	9	4	0,210	SPMT 09T308 ...	VT355	BT15	
SS2-050.05.89.09.2-0	50	22	40	9	5	0,290				
SS2-063.06.89.09.2-0	63	22	40	9	6	0,530				
SS2-080.07.89.09.2-0	80	27	50	9	7	1,180				
SS2-100.08.89.09.2-0	100	32	50	9	8	1,670				





Without coolant Trockenbearbeitung



With coolant Nassbearbeitung

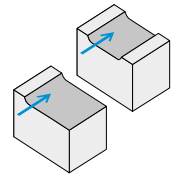
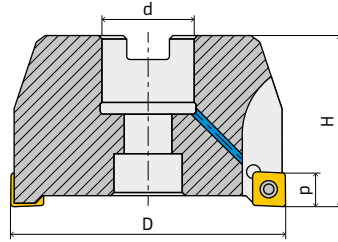

SE3-...

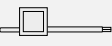

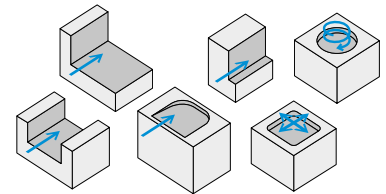
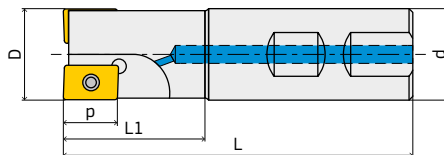

Ordering Code Bestellbezeichnung	Dimensions [mm] Abmessungen [mm]						Weight [kg] Gewicht [kg]	Spare Parts Ersatzteile		
	D	d	H	p	z					
SS3-050.05.89.12.2-0	50	22	40	12	5	0,280	SPMT 120408 ...	VT50	BT20	
SS3-063.06.89.12.2-0	63	22	40	12	6	0,600				
SS3-080.06.89.12.2-0	80	27	50	12	6	0,980				
SS3-100.08.89.12.2-0	100	32	50	12	8	1,540				
SS3-125.09.89.12.2-0	125	40	63	12	9	3,280				

SE5-...

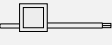





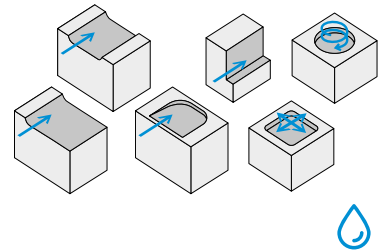
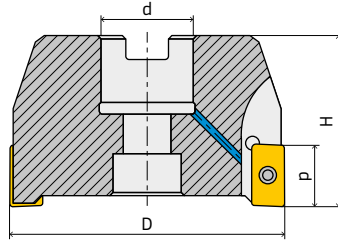

Ordering Code Bestellbezeichnung	Dimensions [mm] Abmessungen [mm]						Weight [kg] Gewicht [kg]	Spare Parts Ersatzteile		
	D	d	L	L1	p	z				
SE5-025.02.90.16.2-0.1	25	25	100	44	17	2	0,380	APKT 1604 ...	VT40	BT15
SE5-032.03.90.16.2-0.1	32	32	110	50	17	3	0,640			
SE5-040.04.90.16.2-0.1	40	32	115	45	17	4	0,760			
Long models Lange Ausführung										
SE5-022L.02.90.16.2-01	22	20	200	60	17	2	0,440	APKT 1604 ...	VT40	BT15
SE5-025L.02.90.16.2-0.1	25	25	200	60	17	2	0,640			
SE5-032L.03.90.16.2-0.1	32	32	200	60	17	3	1,120			
SE5-040L.04.90.16.2-0.1	40	32	200	60	17	4	1,300			

 Without coolant Trockenbearbeitung

 With coolant Nassbearbeitung

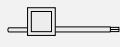
SS5-...



Ordering Code Bestellbezeichnung	Dimensions [mm] Abmessungen [mm]					Weight [kg] Gewicht [kg]	Spare Parts Ersatzteile		
	D	d	H	p	z				
SS5-040.04.90.16.2-0.1	40	16	40	17	4	0,210	APKT 1604 ...	VT40	BT15
SS5-050.05.90.16.2-0.1	50	22	40	17	5	0,290			
SS5-063.06.90.16.2-0.1	63	22	40	17	6	0,530			
SS5-080.07.90.16.2-0.1	80	27	50	17	7	1,180			
SS5-100.08.90.16.2-0.1	100	32	50	17	8	1,670			
SS5-125.09.90.16.2-0.1	125	40	63	17	9	3,110			
SS5-160NC.10.90.16.2-0.1 	160	40	63	17	10	5,280			
SS5-200NC.13.90.16.2-0.1 	200	60	63	17	13	10,200			
SS5-250NC.06.90.16.2-0.1 	250	60	63	17	16	13,810			

SE6-...

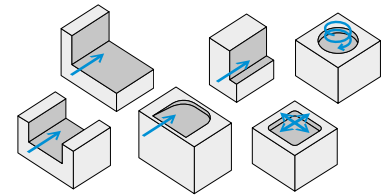
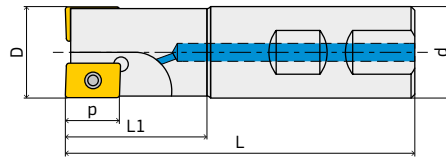

Ordering Code Bestellbezeichnung	Dimensions [mm] Abmessungen [mm]						Weight [kg] Gewicht [kg]	Spare Parts Ersatzteile		
	D	d	L	L1	p	z				
SE6-010.01.90.10.2-0.1	10	16	80	24	10	1	0,100	APKT 1003 ...	VT25	BT08
SE6-011.01.90.10.2-0.1	11	16	80	24	10	1	0,100			
SE6-012.01.90.10.2-0.1	12	16	80	24	10	1	0,120			
SE6-013.01.90.10.2-0.1	13	16	80	24	10	1	0,120			
SE6-014.01.90.10.2-0.1	14	16	80	24	10	1	0,120			
SE6-015.02.90.10.2-0.1	15	16	85	25	10	2	0,120			
SE6-0157.02.90.10.2-0.1	15,7	16	85	25	10	2	0,120			
SE6-016.02.90.10.2-0.1	16	16	85	25	10	2	0,130			
SE6-017.02.90.10.2-0.1	17	16	85	25	10	2	0,130			
SE6-018.02.90.10.2-0.1	18	20	85	25	10	2	0,170			
SE6-0195.03.90.10.2-0.1	19,5	20	90	25	10	3	0,180			
SE6-0197.03.90.10.2-0.1	19,7	20	90	25	10	3	0,180			
SE6-020.03.90.10.2-0.1	20	20	90	25	10	3	0,200			
SE6-022.03.90.10.2-0.1	22	25	95	25	10	3	0,220			
SE6-0247.04.90.10.2-0.1	24,7	25	95	25	10	4	0,320			
SE6-025.03.90.10.2-0.1	25	25	95	25	10	3	0,320			
SE6-025.04.90.10.2-0.1	25	25	95	25	10	4	0,340			
SE6-028.04.90.10.2-0.1	28	25	95	25	10	4	0,340			
SE6-030.04.90.10.2-0.1	30	25	95	25	10	4	0,340			
SE6-0317.05.90.10.2-0.1	31,7	25	95	26	10	5	0,360			
SE6-032.05.90.10.2-0.1	32	25	95	26	10	5	0,380			
Long models Lange Ausführung										
SE6-010L.01.90.10.2-0.1	10	16	150	24	10	1	0,200	APKT 1003 ...	VT25	BT08
SE6-012L.01.90.10.2-0.1	12	16	150	24	10	1	0,200			
SE6-016L.02.90.10.2-0.1	16	16	150	100	10	2	0,210			
SE6-018L.02.90.10.2-0.1	18	16	150	25	10	2	0,330			
SE6-020L.03.90.10.2-0.1	20	20	150	100	10	3	0,330			
SE6-025L.04.90.10.2-0.1	25	20	150	25	10	4	0,350			
SE6-032L.05.90.10.2-0.1	32	25	150	25	10	5	0,560			



Without coolant Trockenbearbeitung



With coolant Nassbearbeitung

SE35-...

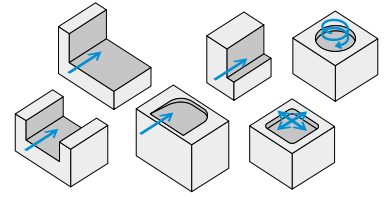
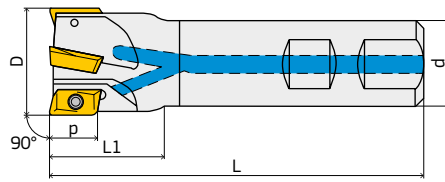

Ordering Code Bestellbezeichnung	Dimensions [mm] Abmessungen [mm]						Weight [kg] Gewicht [kg]	Spare Parts Ersatzteile		
	D	d	L	L1	p	z				
SE35-010.02.90.06.2-0.2	10	10	100	28	5,2	2	0,060	APKT 0602 ...	VT18 06	BT06
SE35-012.03.90.06.2-0.2	12	12	100	30	5,2	3	0,080			
SE35-014.03.90.06.2-0.2	14	12	120	32	5,2	3	0,120			
SE35-016.04.90.06.2-0.2	16	16	120	32	5,2	4	0,160			
SE35-018.04.90.06.2-0.2	18	16	120	32	5,2	4	0,170			
SE35-020.05.90.06.2-0.2	20	20	150	35	5,2	5	0,300			
SE35-025.07.90.06.2-0.2	25	20	150	35	5,2	7	0,320			
SE35-032.08.90.06.2-0.2	32	25	150	35	5,2	8	0,560			

SS36-...

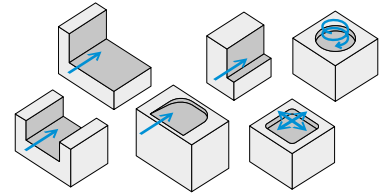
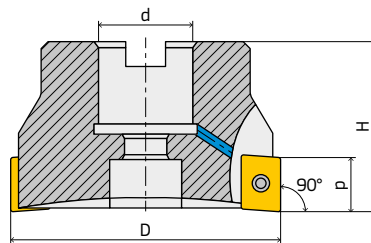



Ordering Code Bestellbezeichnung	Dimensions [mm] Abmessungen [mm]					Weight [kg] Gewicht [kg]	Spare Parts Ersatzteile		
	D	d	H	p	z				
SS36-032.08.90.06.2-0.2	32	16	40	5,2	8	0,250	APKT 0602 ...	VT18 06	BT06
SS36-032.10.90.06.2-0.2	40	16	40	5,2	10	0,270			
SS36-032.11.90.06.2-0.2	50	22	40	5,2	11	0,430			

Without coolant Trockenbearbeitung

With coolant Nassbearbeitung

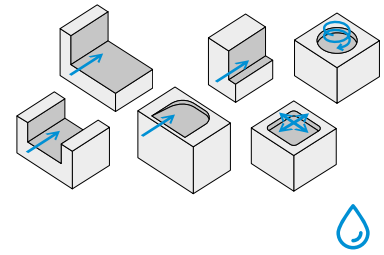
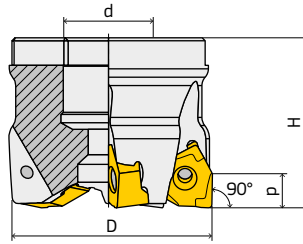

SS37-...

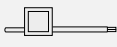

Ordering Code Bestellbezeichnung	Dimensions [mm] Abmessungen [mm]					Weight [kg] Gewicht [kg]	Spare Parts Ersatzteile		
	D	d	H	p	z				
SS37-050.05.90.08.2-2	50	22	40	7	5	0,336	WNEU 080608-M ...	VT40 835	BT15
SS37-063.06.90.08.2-2	63	22	40	7	6	0,476			
SS37-080.07.90.08.2-2	80	27	50	7	7	1,084			
SS37-100.08.90.08.2-2	100	32	50	7	8	1,525			
SS37-125.10.90.08.2-2	125	40	63	7	10	3,110			
SS37-160.11.90.08.2-2	160	40	63	7	11	5,280			

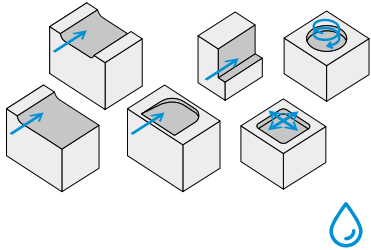
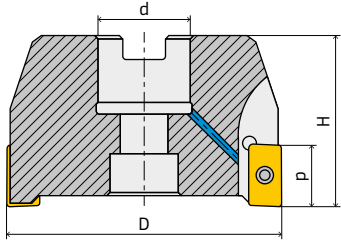

SS6-...



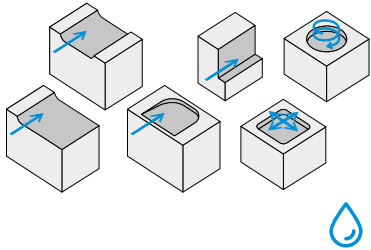
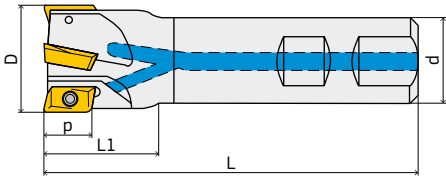
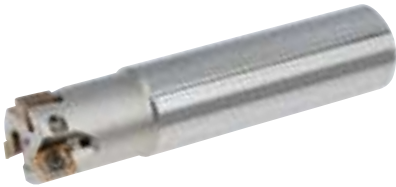

Ordering Code Bestellbezeichnung	Dimensions [mm] Abmessungen [mm]						Weight [kg] Gewicht [kg]	Spare Parts Ersatzteile		
	D	d	H	p	z					
SS6-040.06.90.10.2-0.1	40	16	40	10	6	0,270	APKT 1003 ...	VT25	BT08	
SS6-050.07.90.10.2-0.1	50	22	40	10	7	0,430				
SS6-063.08.90.10.2-0.1	63	22	40	10	8	0,610				
SS6-080.11.90.10.2-0.1	80	27	50	10	11	1,220				
SS6-100.12.90.10.2-0.1	100	32	50	10	12	1,980				

SE7-...

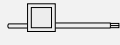





Ordering Code Bestellbezeichnung	Dimensions [mm] Abmessungen [mm]						Weight [kg] Gewicht [kg]	Spare Parts Ersatzteile		
	D	d	L	L1	p	z				
SE7-020.03.90.10.2-1	20	20	100	30	9	3	0,220	LNMX 1006 ...	VT30 745	BT09
SE7-025.03.90.10.2-1	25	25	115	35	9	3	0,400			
SE7-032.04.90.10.2-1	32	25	125	40	9	4	0,520			
Long models Lange Ausführung										
SE7-020L.03.90.10.2-1	20	20	150	50	9	3	0,340	LNMX 1006 ...	VT30 745	BT09
SE7-025L.03.90.10.2-1	25	25	150	50	9	3	0,520			
SE7-032L.04.90.10.2-1	32	32	200	60	9	4	1,160			

 Without coolant Trockenbearbeitung

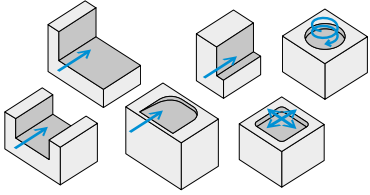
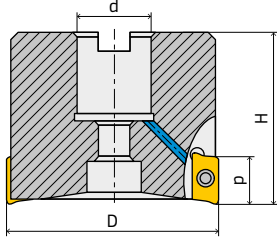
 With coolant Nassbearbeitung



SS7-...

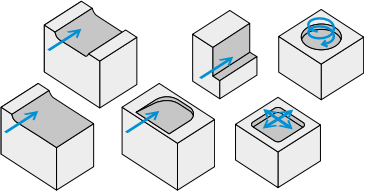
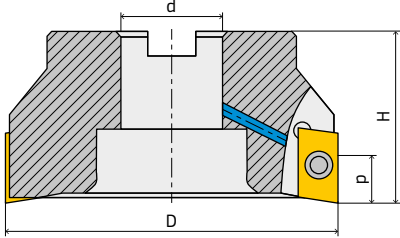

Ordering Code Bestellbezeichnung	Dimensions [mm] Abmessungen [mm]					Weight [kg] Gewicht [kg]	Spare Parts Ersatzteile		
	D	d	H	p	z				
SS7-040.05.90.10.2-1	40	16	40	9	5	0,260	LNMX 1006 ...	VT30 745	BT09
SS7-050.07.90.10.2-1	50	22	40	9	7	0,380			
SS7-063.09.90.10.2-1	63	22	40	9	9	0,600			

SS8-...



Ordering Code Bestellbezeichnung	Dimensions [mm] Abmessungen [mm]					Weight [kg] Gewicht [kg]	Spare Parts Ersatzteile		
	D	d	H	p	z				
SS8-050.05.90.15.2-1	50	22	40	14	5	0,320	LNMX 1510 ...	VT40 735	BT15
SS8-060.06.90.15.2-1	63	22	40	14	6	0,520			
SS8-080.07.90.15.2-1	80	27	50	14	7	1,120			
SS8-100.08.90.15.2-1	100	32	50	14	8	1,830			
SS8-125.10.90.15.2-1	125	40	63	14	10	3,520			
SS8-160.11.90.15.2-1	160	40	63	14	11	5,280			



Without coolant Trockenbearbeitung



With coolant Nassbearbeitung

SE9-...

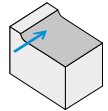
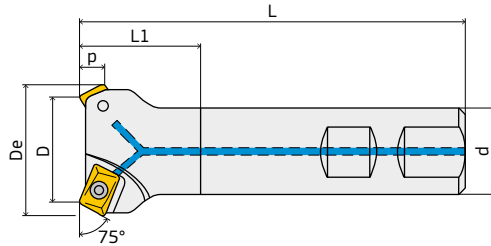

Ordering Code Bestellbezeichnung	Dimensions [mm] Abmessungen [mm]							Weight [kg] Gewicht [kg]	Spare Parts Ersatzteile		
	D	De	d	L	L1	p	z				
SE9-025.02.75.10.2-0.1	25	28,6	20	95	25	4	2	0,220	APKT 1003 ...	VT25	BT08
SE9-032.03.75.10.2-0.1	32	35,6	25	95	25	4	3	0,320			
SE9-040.04.75.10.2-0.1	40	43,6	25	100	25	4	4	0,400			

SS9-...

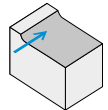
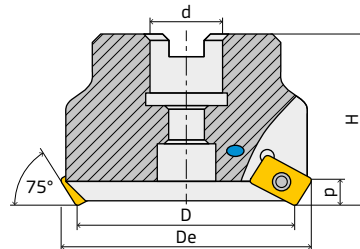

Ordering Code Bestellbezeichnung	Dimensions [mm] Abmessungen [mm]						Weight [kg] Gewicht [kg]	Spare Parts Ersatzteile		
	D	De	d	H	p	z				
SS9-050.05.75.10.2-0.1	50	54	22	40	6,5	5	0,360	APKT 1003 ...	VT25	BT08
SS9-063.06.75.10.2-0.1	63	67	22	40	6,5	6	0,600			

SS10-...

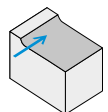
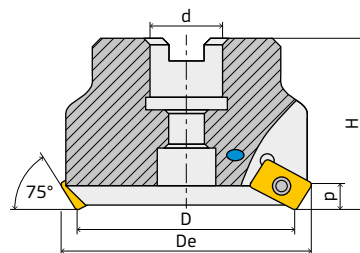

Ordering Code Bestellbezeichnung	Dimensions [mm] Abmessungen [mm]						Weight [kg] Gewicht [kg]	Spare Parts Ersatzteile		
	D	De	d	H	p	z				
SS10-050.03.75.16.2-0.1	50	54	16	40	6,5	3	0,310	APKT 1604 ...	VT40	BT15
SS10-063.04.75.16.2-0.1	63	67	22	40	6,5	4	0,540			
SS10-080.05.75.16.2-0.1	80	84	27	50	6,5	5	1,150			
SS10-100.06.75.16.2-0.1	100	104	32	50	6,5	6	1,800			
SS10-125.07.75.16.2-0.1	125	129	40	63	6,5	7	3,140			





Without coolant Trockenbearbeitung

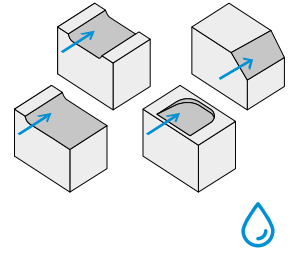
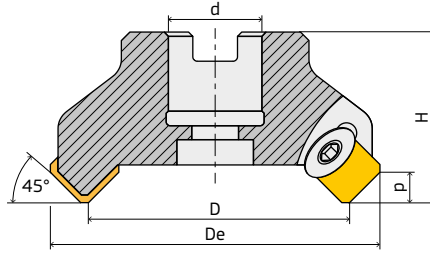

With coolant Nassbearbeitung

SS11-...



Ordering Code Bestellbezeichnung	Dimensions [mm] Abmessungen [mm]											Weight [kg] Gewicht [kg]	Spare Parts Ersatzteile
	D	De	d	d1	c	e	a	b	H	p	z		
SS11-050.04.45.12.2-0.1	50	63	22	-	17	21	10,4	6,3	48	6	4	0,600	SEKN 1203 ... SEKR 1203 ...
SS11-063.05.45.12.2-0.1	63	76	22	-	19	21	10,4	6,3	40	6	5	0,690	
SS11-080.06.45.12.2-0.1	80	93	27	-	38	24	12,4	7	50	6	6	1,370	
SS11-100.06.45.12.2-0.1	100	113	32	-	45	26	14,4	8	50	6	6	2,000	
SS11-125.07.45.12.2-0.1	125	138	40	-	56	32	16,4	9	63	6	7	3,900	
SS11-160DC.07.45.12.2-0.1	160	173	40	66,7	86	32	16,4	9	63	6	7	5,900	
SS11-200DC.10.45.12.2-0.1	200	213	60	101,7	129	32	25,7	14	63	6	10	15,000	
SS11-250DC.13.45.12.2-0.1	250	263	60	101,7	178	32	25,7	14	63	6	13	15,000	

Spare Parts Ersatzteile				
 Support Unterlagplatte	 Insert locking screw Spannschraube WSP	 Screw support Schraube für Unterlagplatte	 Key Schlüssel	 Key Schlüssel
AKE12,4	CVB55	VF4	BT25 – TORX PLUS	BT 08

SE12-...

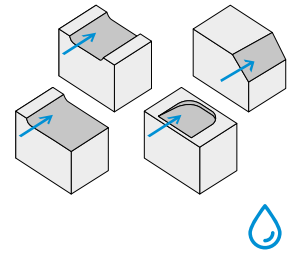
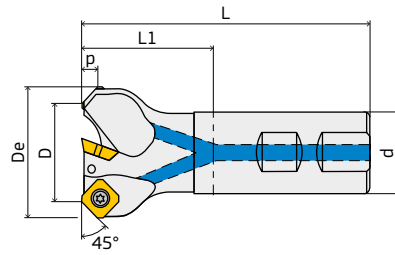

Ordering Code Bestellbezeichnung	Dimensions [mm] Abmessungen [mm]								Weight [kg] Gewicht [kg]	Spare Parts Ersatzteile		
	D	De	d	L	L1	p	z					
SE12-025.02.45.12.2-0.1	25	38	25	100	44	6	2	0,370	SEHT 1204 ... SEKT 1204 ...	VT50	BT20	
SE12-032.03.45.12.2-0.1	32	45	25	110	54	6	3	0,420				
SE12-040.04.45.12.2-0.1	40	53	32	115	55	6	4	0,780				

SS12-...

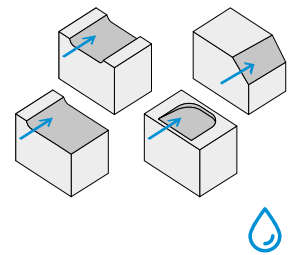
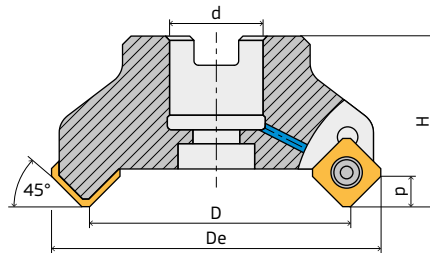

Ordering Code Bestellbezeichnung	Dimensions [mm] Abmessungen [mm]							Weight [kg] Gewicht [kg]	Spare Parts Ersatzteile		
	D	De	d	H	p	z					
SS12-040.03.45.12.2-0.1	40	53	16	40	6	3	0,270	SEHT 1204 ... SEKT 1204 ...	VT50	BT20	
SS12-050.04.45.12.2-0.1	50	63	22	48	6	4	0,480				
SS12-063.05.45.12.2-0.1	63	76	22	48	6	5	0,760				
SS12-080.06.45.12.2-0.1	80	93	27	50	6	6	1,270				
SS12-100.06.45.12.2-0.1	100	113	32	50	6	6	1,790				
SS12-125.07.45.12.2-0.1	125	138	40	63	6	7	3,470				
SS12-160.08.45.12.2-0.1	160	173	40	63	6	8	5,280				
SS12-200NC.12.45.12.2-0.1	200	213	60	63	6	12	7,800				
SS12-250NC.16.45.12.2-0.1	250	263	60	63	6	16	11,100				
SS12-040F.04.45.12.2-0.1	40	53	16	40	6	4	0,270				
SS12-050F.05.45.12.2-0.1	50	63	22	48	6	5	0,480				
SS12-063F.06.45.12.2-0.1	63	76	22	48	6	6	0,760				
SS12-080F.07.45.12.2-0.1	80	93	27	50	6	7	1,270				
SS12-100F.08.45.12.2-0.1	100	113	32	50	6	8	1,790				
SS12-125F.09.45.12.2-0.1	125	138	40	63	6	9	3,470				
SS12-160F.10.45.12.2-0.1	160	173	40	63	6	10	5,280				

Without coolant Trockenbearbeitung

With coolant Nassbearbeitung

SS13-...

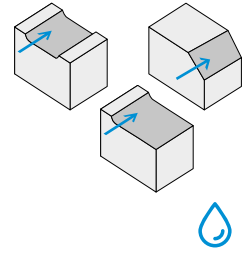
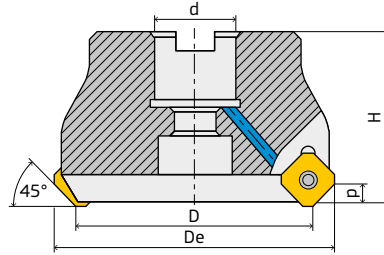

Ordering Code Bestellbezeichnung	Dimensions [mm] Abmessungen [mm]							Weight [kg] Gewicht [kg]	Spare Parts Ersatzteile		
	D	De	d	H	p	z					
SS13-050.04.45.12.2-1	50	63	22	48	6	4	0,520	SDHT 1204 ...	VT45P	BT20	
SS13-063.05.45.12.2-1	63	76	22	48	6	5	0,800				
SS13-080.06.45.12.2-1	80	93	27	50	6	6	1,300				
SS13-100.06.45.12.2-1	100	113	32	50	6	6	1,770				
SS13-125.07.45.12.2-1	125	138	40	63	6	7	3,700				
SS13-160.08.45.12.2-1	160	173	40	63	6	8	5,280				
SS13-200NC.12.45.12.2-1	200	213	60	63	6	12	14,000				
SS13-250NC.16.45.12.2-1	250	263	60	63	6	16	14,000				

SS16-...

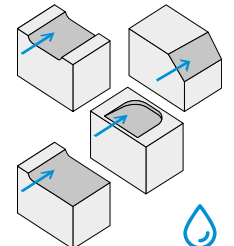
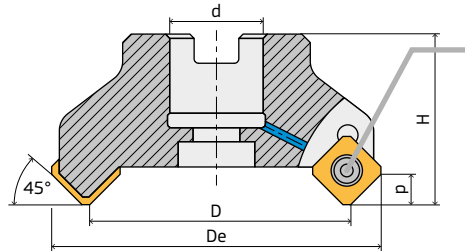

Ordering Code Bestellbezeichnung	Dimensions [mm] Abmessungen [mm]							Weight [kg] Gewicht [kg]	Spare Parts Ersatzteile			
	D	De	d	H	p	z						
SS16-050.04.45.12.2-1	50	63	22	40	6	4	0,520	SNEX 1206 ... SNMX 1206 ...	ONMU 1205 ...	VT40S	BT20	
SS16-063.06.45.12.2-1	63	76	22	40	6	6	0,640					
SS16-080.07.45.12.2-1	80	93	27	50	6	7	1,250					
SS16-100.08.45.12.2-1	100	113	32	50	6	8	1,830					
SS16-125.10.45.12.2-1	125	138	40	63	6	10	3,920					
SS16-160.12.45.12.2-1	160	173	40	63	6	12	5,280					
SS16-200NC.14.45.12.2-1	200	213	60	63	6	14	10,200					
SS16-250NC.16.45.12.2-1	250	263	60	63	6	16	13,900					
SS16-050F.06.45.12.2-1	50	63	22	40	6	6	0,520					
SS16-063F.08.45.12.2-1	63	76	22	40	6	8	0,640					
SS16-080F.10.45.12.2-1	80	93	27	50	6	10	1,250					
SS16-100F.12.45.12.2-1	100	113	32	50	6	12	1,830					
SS16-125F.16.45.12.2-1	125	138	40	63	6	16	3,920					
SS16-160F.20.45.12.2-1	160	173	40	63	6	20	5,280					

Without coolant Trockenbearbeitung

With coolant Nassbearbeitung

SE17-...

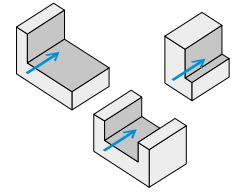
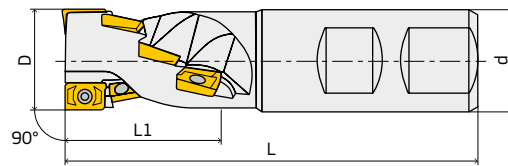

Ordering Code Bestellbezeichnung	Dimensions [mm] Abmessungen [mm]							Weight [kg] Gewicht [kg]	Spare Parts Ersatzteile		
	D	d	L	L1	p	K	z				
SE17-025.02.90.16.2-0.1	25	25	105	29	17	1	2	0,320	APKT 1604 ...	VT40	BT15
SE17-032.06.90.16.2-0.1	32	32	115	44	17	2	6	0,520			
SE17-040.08.90.16.2-0.1	40	32	130	58	17	2	8	0,760			

K Forward feed factor Vorschubfaktor

Shell type roughing cutter Aufsteckschruppfräser

SS17-...

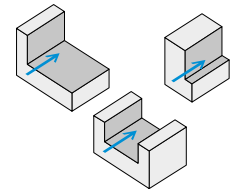
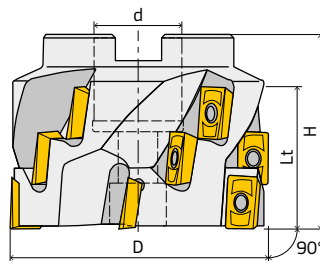

Ordering Code Bestellbezeichnung	Dimensions [mm] Abmessungen [mm]							Weight [kg] Gewicht [kg]	Spare Parts Ersatzteile		
	D	d	H	Lt	p	K	z				
SS17-050.06.90.16.2-0.1	50	27	50	30	16	3	6	0,460	APKT 1604 ...	VT40	BT15
SS17-063.12.90.16.2-0.1	63	27	60	44	16	4	12	0,820			
SS17-080.15.90.16.2-0.1	80	32	60	44	16	5	15	1,380			
SS17-100.18.90.16.2-0.1	100	40	60	44	16	6	18	1,730			

K Forward feed factor Vorschubfaktor



Without coolant Trockenbearbeitung



With coolant Nassbearbeitung

SE18-...

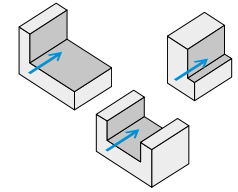
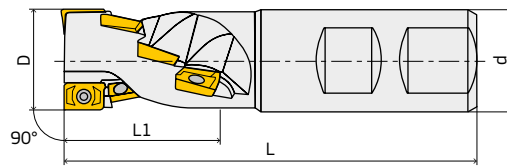

Ordering Code Bestellbezeichnung	Dimensions [mm] Abmessungen [mm]							Weight [kg] Gewicht [kg]	Spare Parts Ersatzteile		
	D	d	L	L1	p	K	z				
SE18-020.04.90.10.2-0.1	20	20	87	28	10	1	4	0,200	APKT 1003 ...	VT25	BT08
SE18-025.08.90.10.2-0.1	25	25	105	37	10	2	8	0,360			
SE18-032.10.90.10.2-0.1	32	32	115	46	10	2	10	0,600			
SE18-032.15.90.10.2-0.1	32	32	115	46	10	3	15	0,600			
SE18-040.18.90.10.2-0.1	40	32	130	55	10	3	18	0,780			

K Forward feed factor Vorschubfaktor

Shell type roughing cutter Aufsteckschruppfräser

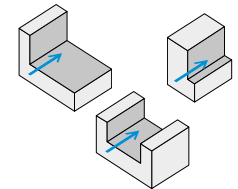
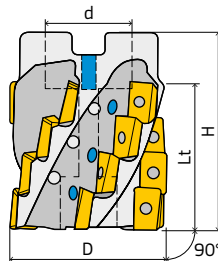

SS18-...



Ordering Code Bestellbezeichnung	Dimensions [mm] Abmessungen [mm]							Weight [kg] Gewicht [kg]	Spare Parts Ersatzteile		
	D	d	H	Lt	p	K	Z				
SS18-040.12.90.10.2-0.1	40	16	50	37	10	3	12	0,250	APKT 1003 ...	VT25	BT08
SS18-050.15.90.10.2-0.1	50	22	60	46	10	3	15	0,510			
SS18-063.20.90.10.2-0.1	63	27	60	46	10	4	20	0,940			

Without coolant Trockenbearbeitung

With coolant Nassbearbeitung

Material group Werkstoffgruppe	Insert grade WSP – Sorte		Without coolant Trockenbe- arbeitung	With coolant Nassbe- arbeitung	A4M-A1	A5M-B1	A6M-C1
	ISO Code				P20	P25	P30
	Material Werkstoff						
P	Structural steel Baustahl		●	○	190–290	175–265	160–240
	Heat treated steel Vergütungsstahl		●	○	160–230	145–215	140–190
	Tool steel Werkzeugstahl		●	○	145–210	130–190	120–175
	Hardened steel Gehärteter Stahl		●	○	110–170		100–160
M	Stainless steel Nichtrostender Stahl	Austenitic Austenitisch	●	○		90–150	
		Austenitic hardened Austenitisch gehärtet	●	○		60–110	
K	Grey cast iron Grauguss		●	○		140–300	
	Nodular graphite cast iron Gusseisen mit Kugelgraphit		●	○		100–160	
N	Aluminium Aluminium		●	○			
	Copper and copper alloys Kupfer und Kupferlegierungen		●	○			
S	Heat resistant alloys Warmfeste Legierungen		○	●			
	Titanium alloys Titanlegierungen		○	●			

● Recommended application Empfohlene Anwendung

○ Alternative application reduced by 30–50% reduced Alternative Anwendung um 30–50% reduzieren

A7M-D1	A8M-E1	B7M-F1	B8M-G1	C3M-H1	C4M-I1	D2M-J1	D3M-K1
P35	P40	M35	M40	K15	K20	N10	N15
150-230	100-220				200-300		
130-180	145-215				180-250		
110-160	130-190				160-220		
					120-180		
80-140	70-130	110-180	100-160				
		80-130	70-120				
				180-360	150-320		
				140-250	110-180		
						400-2500	500-3000
						120-400	160-500
			30-70			25-80	
			30-80			30-80	

APKT 1003 PDTR-M A6M-A2

Material group Werkstoffgruppe	Material Werkstoff	Gr. N°	VDI Group VDI Gruppe	Material Examples Material Beispiel	Hardness Härte	D.O.C. [mm]		Feed Vorschub [mm/rev]		Vc [m/min]		Suggested Starting Parameters Empfohlene Beginnend Parameter		
						min	max	min	max	min	max	D.O.C.	Feed	Vc
P	Non alloyed Unlegiert	1	1	C35, Ck45, 1020,	125 HB	0,5	9	0,13	0,26	190	330	2	0,17	250
			2	1045, 1060,	190 HB	0,5	9	0,13	0,26	190	300	2	0,17	220
			3	28Mn6	250 HB	0,5	9	0,13	0,26	190	250	2	0,17	200
	Low alloyed Niedrig legiert	2	6	42CrMo4, St50,	180 HB	0,5	9	0,11	0,21	150	240	2	0,15	200
			4,6	Ck60, 4140, 4340,	230 HB	0,5	9	0,11	0,21	150	210	2	0,15	180
			5,7	100Cr6	280 HB	0,5	9	0,11	0,18	130	190	2	0,13	150
			8		350 HB	0,5	9	0,11	0,18	130	170	2	0,13	140
	High alloyed Hoch legiert	3	10	X40CrMoV5, H13,	220 HB	0,5	6,4	0,08	0,18	90	150	1,5	0,13	130
			10	M42, D3, S6-5-2,	280 HB	0,5	6,4	0,08	0,18	90	130	1,5	0,13	120
			11	12Ni19	320 HB	0,5	6,4	0,08	0,15	60	110	1,5	0,12	100
11				350 HB	0,5	6,4	0,08	0,15	60	90	1,5	0,12	80	
M	Austenitic Austenitisch	4	14	304, 316,	180 HB	0,5	9	0,11	0,21	190	250	2	0,15	220
			14	X5CrNi18-19	240 HB	0,5	9	0,08	0,18	160	210	2	0,15	190
	Duplex Duplex	5	14	X2CrNi23-4,	290 HB	0,5	6,4	0,08	0,15	70	130	1,5	0,12	100
			14	S31500	310 HB	0,5	6,4	0,08	0,15	70	120	1,5	0,12	90
Austenitic hardened Austenitisch gehärtet	6	12	410, X6Cr17,	200 HB	0,5	9	0,11	0,21	150	210	2	0,15	190	
		13	17-4 PH, 430	42 HRc	0,5	6,4	0,11	0,16	90	150	1,5	0,12	130	
K	Grey cast iron Grauguss	7	15	GG20, GG40,	150 HB	0,5	9	0,13	0,26	150	240	2	0,17	200
			15	EN-GJL-250,	200 HB	0,5	9	0,13	0,26	150	220	2	0,17	180
			16	No30B	250 HB	0,5	9	0,13	0,26	150	190	2	0,17	160
	Nodular graphite cast iron Gusseisen mit Kugelgraphit	8	17,19	GGG40, GGG70,	150 HB	0,5	9	0,11	0,23	100	200	2	0,15	180
			17,19	50005	200 HB	0,5	9	0,11	0,23	100	180	2	0,15	150
			18,20		250 HB	0,5	9	0,11	0,23	100	150	2	0,15	130
N	Al (>8% Si)	12	25	AlSi12	130 HB	0,5	9	0,13	0,26	200	400	2	0,18	280
S	Heat resistant alloys Warmfeste Legierungen	9	31,32	Incoloy 800	240 HB	0,5	6,4	0,08	0,15	25	45	1,5	0,12	32
			33	Inconel 700	250 HB	0,5	6,4	0,08	0,15	25	45	1,5	0,12	30
			34	Stellite 21	350 HB	0,5	6,4	0,08	0,15	25	45	1,5	0,12	30
	Titanium alloys Titanlegierungen	10	36	TiAl6V4	-	0,5	6,4	0,08	0,16	40	65	1,5	0,13	55
37			T40	-	0,5	6,4	0,08	0,15	30	55	1,5	0,12	40	
H	Steel Stahl	11	38	X100CrMo13,	45 HRc	0,5	3,2	0,07	0,15	40	80	1	0,1	60
			38	440C,	50 HRc	0,5	1,9	0,07	0,13	40	70	0,8	0,09	55
			38	G-X260NiCr42	55 HRc	0,5	1	0,07	0,11	40	60	0,5	0,09	50
	Chilled cast iron Hartguss	11	40	Ni-Hard 2	400 HB	0,5	2,6	0,07	0,15	40	80	0,8	0,1	50
			41	G-X300CrMo15	55 HRc	0,5	1	0,07	0,11	30	60	0,5	0,09	40
	White cast iron Weißguss													

APKT 100304 PDTR-M A6M-A2

Material group Werkstoffgruppe	Material Werkstoff	Gr. N°	VDI Group VDI Gruppe	Material Examples Material Beispiel	Hardness Härte	D.O.C. [mm]		Feed Vorschub [mm/rev]		Vc [m/min]		Suggested Starting Parameters Empfohlene Beginnend Parameter		
						min	max	min	max	min	max	D.O.C.	Feed	Vc
P	Non alloyed Unlegiert	1	1	C35, Ck45, 1020,	125 HB	0,5	9	0,11	0,2	190	330	2	0,14	250
			2	1045, 1060,	190 HB	0,5	9	0,11	0,2	190	300	2	0,14	220
			3	28Mn6	250 HB	0,5	9	0,11	0,2	190	250	2	0,14	200
	Low alloyed Niedrig legiert	2	6	42CrMo4, St50,	180 HB	0,5	9	0,09	0,16	150	240	2	0,12	200
			4,6	Ck60, 4140, 4340,	230 HB	0,5	9	0,09	0,16	150	210	2	0,12	180
			5,7	100Cr6	280 HB	0,5	9	0,09	0,14	130	190	2	0,11	150
			8		350 HB	0,5	9	0,09	0,14	130	170	2	0,11	140
	High alloyed Hoch legiert	3	10	X40CrMoV5, H13,	220 HB	0,5	6,4	0,07	0,14	90	150	1,5	0,11	130
			10	M42, D3, S6-5-2,	280 HB	0,5	6,4	0,07	0,14	90	130	1,5	0,11	120
			11	12Ni19	320 HB	0,5	6,4	0,07	0,11	60	110	1,5	0,1	100
11				350 HB	0,5	6,4	0,07	0,11	60	90	1,5	0,1	80	
M	Austenitic Austenitisch	4	14	304, 316,	180 HB	0,5	9	0,09	0,16	190	250	2	0,12	220
			14	X5CrNi18-19	240 HB	0,5	9	0,07	0,14	160	210	2	0,12	190
	Duplex Duplex	5	14	X2CrNi23-4,	290 HB	0,5	6,4	0,07	0,11	70	130	1,5	0,1	100
			14	S31500	310 HB	0,5	6,4	0,07	0,11	70	120	1,5	0,1	90
Austenitic hardened Austenitisch gehärtet	6	12	410, X6Cr17,	200 HB	0,5	9	0,09	0,16	150	210	2	0,12	190	
		13	17-4 PH, 430	42 HRc	0,5	6,4	0,09	0,12	90	150	1,5	0,1	130	
K	Grey cast iron Grauguss	7	15	GG20, GG40,	150 HB	0,5	9	0,11	0,2	150	240	2	0,14	200
			15	EN-GJL-250,	200 HB	0,5	9	0,11	0,2	150	220	2	0,14	180
			16	No30B	250 HB	0,5	9	0,11	0,2	150	190	2	0,14	160
	Nodular graphite cast iron Gusseisen mit Kugelgraphit	8	17,19	GGG40, GGG70,	150 HB	0,5	9	0,09	0,17	100	200	2	0,12	180
			17,19	50005	200 HB	0,5	9	0,09	0,17	100	180	2	0,12	150
			18,20		250 HB	0,5	9	0,09	0,17	100	150	2	0,12	130
N	Al (>8% Si)	12	25	AlSi12	130 HB	0,5	9	0,11	0,2	200	400	2	0,16	280
S	Heat resistant alloys Warmfeste Legierungen	9	31,32	Incoloy 800	240 HB	0,5	6,4	0,07	0,11	25	45	1,5	0,1	32
			33	Inconel 700	250 HB	0,5	6,4	0,07	0,11	25	45	1,5	0,1	30
			34	Stellite 21	350 HB	0,5	6,4	0,07	0,11	25	45	1,5	0,1	30
	Titanium alloys Titanlegierungen	10	36	TiAl6V4	-	0,5	6,4	0,07	0,12	40	65	1,5	0,11	55
37			T40	-	0,5	6,4	0,07	0,11	30	55	1,5	0,1	40	
H	Steel Stahl	11	38	X100CrMo13,	45 HRc	0,5	3,2	0,06	0,11	40	80	1	0,09	60
			38	440C,	50 HRc	0,5	1,9	0,06	0,1	40	70	0,8	0,08	55
			38	G-X260NiCr42	55 HRc	0,5	1	0,06	0,09	40	60	0,5	0,07	50
	Chilled cast iron Hartguss	11	40	Ni-Hard 2	400 HB	0,5	2,6	0,06	0,11	40	80	0,8	0,09	50
			41	G-X300CrMo15	55 HRc	0,5	1	0,06	0,09	30	60	0,5	0,07	40
	White cast iron Weißguss													

APKT 100312 PDTR-M A6M-A2, APKT 100316 PDTR-M A6M-A2

Material group Werkstoffgruppe	Material Werkstoff	Gr. N°	VDI Group VDI Gruppe	Material Examples Material Beispiel	Hardness Härte	D.O.C. [mm]		Feed Vorschub [mm/rev]		Vc [m/min]		Suggested Starting Parameters Empfohlene Beginnend Parameter		
						min	max	min	max	min	max	D.O.C.	Feed	Vc
P	Non alloyed Unlegiert	1	1	C35, Ck45, 1020,	125 HB	0,5	9	0,13	0,28	190	330	2	0,2	250
			2	1045, 1060,	190 HB	0,5	9	0,13	0,28	190	300	2	0,2	220
			3	28Mn6	250 HB	0,5	9	0,13	0,28	190	250	2	0,2	200
	Low alloyed Niedrig legiert	2	6	42CrMo4, St50,	180 HB	0,5	9	0,11	0,22	150	240	2	0,18	200
			4,6	Ck60, 4140, 4340,	230 HB	0,5	9	0,11	0,22	150	210	2	0,18	180
			5,7	100Cr6	280 HB	0,5	9	0,11	0,19	130	190	2	0,16	150
			8		350 HB	0,5	9	0,11	0,19	130	170	2	0,16	140
	High alloyed Hoch legiert	3	10	X40CrMoV5, H13,	220 HB	0,5	6,4	0,08	0,19	90	150	1,5	0,16	130
			10	M42, D3, S6-5-2,	280 HB	0,5	6,4	0,08	0,19	90	130	1,5	0,16	120
			11	12Ni19	320 HB	0,5	6,4	0,08	0,16	60	110	1,5	0,14	100
11				350 HB	0,5	6,4	0,08	0,16	60	90	1,5	0,14	80	
M	Austenitic Austenitisch	4	14	304, 316,	180 HB	0,5	9	0,11	0,22	190	250	2	0,18	220
			14	X5CrNi18-19	240 HB	0,5	9	0,08	0,19	160	210	2	0,18	190
	Duplex Duplex	5	14	X2CrNi23-4,	290 HB	0,5	6,4	0,08	0,16	70	130	1,5	0,14	100
			14	S31500	310 HB	0,5	6,4	0,08	0,16	70	120	1,5	0,14	90
Austenitic hardened Austenitisch gehärtet	6	12	410, X6Cr17,	200 HB	0,5	9	0,11	0,22	150	210	2	0,18	190	
		13	17-4 PH, 430	42 HRc	0,5	6,4	0,11	0,18	90	150	1,5	0,14	130	
K	Grey cast iron Grauguss	7	15	GG20, GG40,	150 HB	0,5	9	0,13	0,28	150	240	2	0,2	200
			15	EN-GJL-250,	200 HB	0,5	9	0,13	0,28	150	220	2	0,2	180
			16	No30B	250 HB	0,5	9	0,13	0,28	150	190	2	0,2	160
	Nodular graphite cast iron Gusseisen mit Kugelgraphit	8	17,19	GGG40, GGG70,	150 HB	0,5	9	0,11	0,25	100	200	2	0,18	180
			17,19	50005	200 HB	0,5	9	0,11	0,25	100	180	2	0,18	150
			18,20		250 HB	0,5	9	0,11	0,25	100	150	2	0,18	130
N	Al (>8% Si)	12	25	AlSi12	130 HB	0,5	9	0,13	0,28	200	400	2	0,22	280
S	Heat resistant alloys Warmfeste Legierungen	9	31,32	Incoloy 800	240 HB	0,5	6,4	0,08	0,16	25	45	1,5	0,14	32
			33	Inconel 700	250 HB	0,5	6,4	0,08	0,16	25	45	1,5	0,14	30
			34	Stellite 21	350 HB	0,5	6,4	0,08	0,16	25	45	1,5	0,14	30
	Titanium alloys Titanlegierungen	10	36	TiAl6V4	-	0,5	6,4	0,08	0,18	40	65	1,5	0,16	55
37			T40	-	0,5	6,4	0,08	0,16	30	55	1,5	0,14	40	
H	Steel Stahl	11	38	X100CrMo13,	45 HRc	0,5	3,2	0,07	0,16	40	80	1	0,12	60
			38	440C,	50 HRc	0,5	1,9	0,07	0,14	40	70	0,8	0,11	55
			38	G-X260NiCr42	55 HRc	0,5	1	0,07	0,12	40	60	0,5	0,11	50
	Chilled cast iron Hartguss	11	40	Ni-Hard 2	400 HB	0,5	2,6	0,07	0,16	40	80	0,8	0,12	50
			41	G-X300CrMo15	55 HRc	0,5	1	0,07	0,12	30	60	0,5	0,11	40
	White cast iron Weißguss													

APKT 100332 PDTR-M A6M-A2

Material group Werkstoffgruppe	Material Werkstoff	Gr. N°	VDI Group VDI Gruppe	Material Examples Material Beispiel	Hardness Härte	D.O.C. [mm]		Feed Vorschub [mm/rev]		Vc [m/min]		Suggested Starting Parameters Empfohlene Beginnend Parameter		
						min	max	min	max	min	max	D.O.C.	Feed	Vc
P	Non alloyed Unlegiert	1	1	C35, Ck45, 1020,	125 HB	0,5	9	0,13	0,28	190	330	1	0,29	250
			2	1045, 1060,	190 HB	0,5	9	0,13	0,28	190	300	1	0,29	220
			3	28Mn6	250 HB	0,5	9	0,13	0,28	190	250	1	0,29	200
	Low alloyed Niedrig legiert	2	6	42CrMo4, St50,	180 HB	0,5	9	0,11	0,22	150	240	1	0,25	200
			4,6	Ck60, 4140, 4340,	230 HB	0,5	9	0,11	0,22	150	210	1	0,25	180
			5,7	100Cr6	280 HB	0,5	9	0,11	0,19	130	190	1	0,22	150
			8		350 HB	0,5	9	0,11	0,19	130	170	1	0,22	140
	High alloyed Hoch legiert	3	10	X40CrMoV5, H13,	220 HB	0,5	6,4	0,08	0,19	90	150	1	0,22	130
			10	M42, D3, S6-5-2,	280 HB	0,5	6,4	0,08	0,19	90	130	1	0,22	120
			11	12Ni19	320 HB	0,5	6,4	0,08	0,16	60	110	1	0,2	100
11				350 HB	0,5	6,4	0,08	0,16	60	90	1	0,2	80	
M	Austenitic Austenitisch	4	14	304, 316,	180 HB	0,5	9	0,11	0,22	190	250	1	0,25	220
			14	X5CrNi18-19	240 HB	0,5	9	0,08	0,19	160	210	1	0,25	190
	Duplex Duplex	5	14	X2CrNi23-4,	290 HB	0,5	6,4	0,08	0,16	70	130	1	0,2	100
			14	S31500	310 HB	0,5	6,4	0,08	0,16	70	120	1	0,2	90
Austenitic hardened Austenitisch gehärtet	6	12	410, X6Cr17,	200 HB	0,5	9	0,11	0,22	150	210	1	0,25	190	
		13	17-4 PH, 430	42 HRc	0,5	6,4	0,11	0,18	90	150	1	0,2	130	
K	Grey cast iron Grauguss	7	15	GG20, GG40,	150 HB	0,5	9	0,13	0,28	150	240	1	0,29	200
			15	EN-GJL-250,	200 HB	0,5	9	0,13	0,28	150	220	1	0,29	180
			16	No30B	250 HB	0,5	9	0,13	0,28	150	190	1	0,29	160
	Nodular graphite cast iron Gusseisen mit Kugelgraphit	8	17,19	GGG40, GGG70,	150 HB	0,5	9	0,11	0,25	100	200	1	0,25	180
			17,19	50005	200 HB	0,5	9	0,11	0,25	100	180	1	0,25	150
			18,20		250 HB	0,5	9	0,11	0,25	100	150	1	0,25	130
N	Al (>8% Si)	12	25	AlSi12	130 HB	0,5	9	0,13	0,28	200	400	1	0,31	280
S	Heat resistant alloys Warmfeste Legierungen	9	31,32	Incoloy 800	240 HB	0,5	6,4	0,08	0,16	25	45	1	0,2	32
			33	Inconel 700	250 HB	0,5	6,4	0,08	0,16	25	45	1	0,2	30
			34	Stellite 21	350 HB	0,5	6,4	0,08	0,16	25	45	1	0,2	30
	Titanium alloys Titanlegierungen	10	36	TiAl6V4	-	0,5	6,4	0,08	0,18	40	65	1	0,22	55
37			T40	-	0,5	6,4	0,08	0,16	30	55	1	0,2	40	
H	Steel Stahl	11	38	X100CrMo13,	45 HRc	0,5	3,2	0,07	0,16	40	80	0,7	0,17	60
			38	440C,	50 HRc	0,5	1,9	0,07	0,14	40	70	0,7	0,16	55
			38	G-X260NiCr42	55 HRc	0,5	1	0,07	0,12	40	60	0,7	0,15	50
	Chilled cast iron Hartguss	11	40	Ni-Hard 2	400 HB	0,5	2,6	0,07	0,16	40	80	0,7	0,17	50
			41	G-X300CrMo15	55 HRc	0,5	1	0,07	0,12	30	60	0,7	0,15	40
	White cast iron Weißguss													

APKT 100340 PDTR-M A6M-A2

Material group Werkstoffgruppe	Material Werkstoff	Gr. N°	VDI Group VDI Gruppe	Material Examples Material Beispiel	Hardness Härte	D.O.C. [mm]		Feed Vorschub [mm/rev]		Vc [m/min]		Suggested Starting Parameters Empfohlene Beginnend Parameter		
						min	max	min	max	min	max	D.O.C.	Feed	Vc
P	Non alloyed Unlegiert	1	1	C35, Ck45, 1020,	125 HB	0,5	9	0,13	0,46	190	330	1	0,35	250
			2	1045, 1060,	190 HB	0,5	9	0,13	0,46	190	300	1	0,35	220
			3	28Mn6	250 HB	0,5	9	0,13	0,46	190	250	1	0,35	200
	Low alloyed Niedrig legiert	2	6	42CrMo4, St50,	180 HB	0,5	9	0,11	0,36	150	240	1	0,3	200
			4,6	Ck60, 4140, 4340,	230 HB	0,5	9	0,11	0,36	150	210	1	0,3	180
			5,7	100Cr6	280 HB	0,5	9	0,11	0,32	130	190	1	0,27	150
			8		350 HB	0,5	9	0,11	0,32	130	170	1	0,27	140
	High alloyed Hoch legiert	3	10	X40CrMoV5, H13,	220 HB	0,5	6,4	0,08	0,32	90	150	1	0,27	130
			10	M42, D3, S6-5-2,	280 HB	0,5	6,4	0,08	0,32	90	130	1	0,27	120
			11	12Ni19	320 HB	0,5	6,4	0,08	0,26	60	110	1	0,24	100
11				350 HB	0,5	6,4	0,08	0,26	60	90	1	0,24	80	
M	Austenitic Austenitisch	4	14	304, 316,	180 HB	0,5	9	0,11	0,36	190	250	1	0,3	220
			14	X5CrNi18-19	240 HB	0,5	9	0,08	0,32	160	210	1	0,3	190
	Duplex Duplex	5	14	X2CrNi23-4,	290 HB	0,5	6,4	0,08	0,26	70	130	1	0,24	100
			14	S31500	310 HB	0,5	6,4	0,08	0,26	70	120	1	0,24	90
Austenitic hardened Austenitisch gehärtet	6	12	410, X6Cr17,	200 HB	0,5	9	0,11	0,36	150	210	1	0,3	190	
		13	17-4 PH, 430	42 HRc	0,5	6,4	0,11	0,29	90	150	1	0,24	130	
K	Grey cast iron Grauguss	7	15	GG20, GG40,	150 HB	0,5	9	0,13	0,46	150	240	1	0,35	200
			15	EN-GJL-250,	200 HB	0,5	9	0,13	0,46	150	220	1	0,35	180
			16	No30B	250 HB	0,5	9	0,13	0,46	150	190	1	0,35	160
	Nodular graphite cast iron Gusseisen mit Kugelgraphit	8	17,19	GGG40, GGG70,	150 HB	0,5	9	0,11	0,41	100	200	1	0,3	180
			17,19	50005	200 HB	0,5	9	0,11	0,41	100	180	1	0,3	150
			18,20		250 HB	0,5	9	0,11	0,41	100	150	1	0,3	130
N	Al (>8% Si)	12	25	AlSi12	130 HB	0,5	9	0,13	0,46	200	400	1	0,38	280
S	Heat resistant alloys Warmfeste Legierungen	9	31,32	Incoloy 800	240 HB	0,5	6,4	0,08	0,26	25	45	1	0,24	32
			33	Inconel 700	250 HB	0,5	6,4	0,08	0,26	25	45	1	0,24	30
			34	Stellite 21	350 HB	0,5	6,4	0,08	0,26	25	45	1	0,24	30
	Titanium alloys Titanlegierungen	10	36	TiAl6V4	-	0,5	6,4	0,08	0,29	40	65	1	0,27	55
37			T40	-	0,5	6,4	0,08	0,26	30	55	1	0,24	40	
H	Steel Stahl	11	38	X100CrMo13,	45 HRc	0,5	3,2	0,07	0,26	40	80	0,7	0,21	60
			38	440C,	50 HRc	0,5	1,9	0,07	0,23	40	70	0,7	0,2	55
			38	G-X260NiCr42	55 HRc	0,5	1	0,07	0,2	40	60	0,7	0,18	50
	Chilled cast iron Hartguss	11	40	Ni-Hard 2	400 HB	0,5	2,6	0,07	0,26	40	80	0,7	0,21	50
			41	G-X300CrMo15	55 HRc	0,5	1	0,07	0,2	30	60	0,7	0,18	40
	White cast iron Weißguss													

APKT 1604 PDTR-M A6M-A2

Material group Werkstoffgruppe	Material Werkstoff	Gr. N°	VDI Group VDI Gruppe	Material Examples Material Beispiel	Hardness Härte	D.O.C. [mm]		Feed Vorschub [mm/rev]		Vc [m/min]		Suggested Starting Parameters Empfohlene Beginnend Parameter		
						min	max	min	max	min	max	D.O.C.	Feed	Vc
P	Non alloyed Unlegiert	1	1	C35, Ck45, 1020,	125 HB	0,5	15	0,18	0,32	190	330	4	0,23	250
			2	1045, 1060,	190 HB	0,5	15	0,18	0,32	190	300	4	0,23	220
			3	28Mn6	250 HB	0,5	15	0,18	0,32	190	250	4	0,23	200
	Low alloyed Niedrig legiert	2	6	42CrMo4, St50,	180 HB	0,5	15	0,15	0,25	150	240	4	0,2	200
			4,6	Ck60, 4140, 4340,	230 HB	0,5	15	0,15	0,25	150	210	4	0,2	180
			5,7	100Cr6	280 HB	0,5	15	0,15	0,22	130	190	4	0,18	150
			8		350 HB	0,5	15	0,15	0,22	130	170	4	0,18	140
	High alloyed Hoch legiert	3	10	X40CrMoV5, H13,	220 HB	0,5	10,7	0,12	0,22	90	150	3	0,18	130
			10	M42, D3, S6-5-2,	280 HB	0,5	10,7	0,12	0,22	90	130	3	0,18	120
			11	12Ni19	320 HB	0,5	10,7	0,12	0,18	60	110	3	0,16	100
			11		350 HB	0,5	10,7	0,12	0,18	60	90	3	0,16	80
M	Austenitic Austenitisch	4	14	304, 316,	180 HB	0,5	15	0,15	0,25	190	250	4	0,2	220
			14	X5CrNi18-19	240 HB	0,5	15	0,12	0,22	160	210	4	0,2	190
	Duplex Duplex	5	14	X2CrNi23-4,	290 HB	0,5	10,7	0,12	0,18	70	130	3	0,16	100
			14	S31500	310 HB	0,5	10,7	0,12	0,18	70	120	3	0,16	90
Austenitic hardened Austenitisch gehärtet	6	12	410, X6Cr17,	200 HB	0,5	15	0,15	0,25	150	210	4	0,2	190	
		13	17-4 PH, 430	42 HRc	0,5	10,7	0,15	0,2	90	150	3	0,16	130	
K	Grey cast iron Grauguss	7	15	GG20, GG40,	150 HB	0,5	15	0,18	0,32	150	240	4	0,23	200
			15	EN-GJL-250,	200 HB	0,5	15	0,18	0,32	150	220	4	0,23	180
			16	No30B	250 HB	0,5	15	0,18	0,32	150	190	4	0,23	160
	Nodular graphite cast iron Gusseisen mit Kugelgraphit	8	17,19	GGG40, GGG70,	150 HB	0,5	15	0,15	0,28	100	200	4	0,2	180
			17,19	50005	200 HB	0,5	15	0,15	0,28	100	180	4	0,2	150
			18,20		250 HB	0,5	15	0,15	0,28	100	150	4	0,2	130
N	Al (>8% Si)	12	25	AlSi12	130 HB	0,5	15	0,18	0,32	200	400	4	0,25	280
S	Heat resistant alloys Warmfeste Legierungen	9	31,32	Incoloy 800	240 HB	0,5	10,7	0,12	0,18	25	45	3	0,16	32
			33	Inconel 700	250 HB	0,5	10,7	0,12	0,18	25	45	3	0,16	30
			34	Stellite 21	350 HB	0,5	10,7	0,12	0,18	25	45	3	0,16	30
	Titanium alloys Titanlegierungen	10	36	TiAl6V4	-	0,5	10,7	0,12	0,2	40	65	3	0,18	55
37			T40	-	0,5	10,7	0,12	0,18	30	55	3	0,16	40	
H	Steel Stahl	11	38	X100CrMo13,	45 HRc	0,5	5,4	0,1	0,18	40	80	2	0,14	60
			38	440C,	50 HRc	0,5	3,2	0,1	0,16	40	70	1,5	0,13	55
			38	G-X260NiCr42	55 HRc	0,5	1,6	0,1	0,14	40	60	1	0,12	50
	Chilled cast iron Hartguss	11	40	Ni-Hard 2	400 HB	0,5	4,3	0,1	0,18	40	80	1,5	0,14	50
			41	G-X300CrMo15	55 HRc	0,5	1,6	0,1	0,14	30	60	1	0,12	40
	White cast iron Weißguss													

APKT 160416 PDTR-M A6M-A2

Material group Werkstoffgruppe	Material Werkstoff	Gr. N°	VDI Group VDI Gruppe	Material Examples Material Beispiel	Hardness Härte	D.O.C. [mm]		Feed Vorschub [mm/rev]		Vc [m/min]		Suggested Starting Parameters Empfohlene Beginnend Parameter		
						min	max	min	max	min	max	D.O.C.	Feed	Vc
P	Non alloyed Unlegiert	1	1	C35, Ck45, 1020,	125 HB	0,5	15	0,18	0,32	190	330	5	0,23	250
			2	1045, 1060,	190 HB	0,5	15	0,18	0,32	190	300	5	0,23	220
			3	28Mn6	250 HB	0,5	15	0,18	0,32	190	250	5	0,23	200
	Low alloyed Niedrig legiert	2	6	42CrMo4, St50,	180 HB	0,5	15	0,15	0,25	150	240	5	0,2	200
			4,6	Ck60, 4140, 4340,	230 HB	0,5	15	0,15	0,25	150	210	5	0,2	180
			5,7	100Cr6	280 HB	0,5	15	0,15	0,22	130	190	5	0,18	150
			8		350 HB	0,5	15	0,15	0,22	130	170	5	0,18	140
	High alloyed Hoch legiert	3	10	X40CrMoV5, H13,	220 HB	0,5	10,7	0,12	0,22	90	150	3,8	0,18	130
			10	M42, D3, S6-5-2,	280 HB	0,5	10,7	0,12	0,22	90	130	3,8	0,18	120
			11	12Ni19	320 HB	0,5	10,7	0,12	0,18	60	110	3,8	0,16	100
11				350 HB	0,5	10,7	0,12	0,18	60	90	3,8	0,16	80	
M	Austenitic Austenitisch	4	14	304, 316,	180 HB	0,5	15	0,15	0,25	190	250	5	0,2	220
			14	X5CrNi18-19	240 HB	0,5	15	0,12	0,22	160	210	5	0,2	190
	Duplex Duplex	5	14	X2CrNi23-4,	290 HB	0,5	10,7	0,12	0,18	70	130	3,8	0,16	100
			14	S31500	310 HB	0,5	10,7	0,12	0,18	70	120	3,8	0,16	90
Austenitic hardened Austenitisch gehärtet	6	12	410, X6Cr17,	200 HB	0,5	15	0,15	0,25	150	210	5	0,2	190	
		13	17-4 PH, 430	42 HRc	0,5	10,7	0,15	0,2	90	150	3,8	0,16	130	
K	Grey cast iron Grauguss	7	15	GG20, GG40,	150 HB	0,5	15	0,18	0,32	150	240	5	0,23	200
			15	EN-GJL-250,	200 HB	0,5	15	0,18	0,32	150	220	5	0,23	180
			16	No30B	250 HB	0,5	15	0,18	0,32	150	190	5	0,23	160
	Nodular graphite cast iron Gusseisen mit Kugelgraphit	8	17,19	GGG40, GGG70,	150 HB	0,5	15	0,15	0,28	100	200	5	0,2	180
			17,19	50005	200 HB	0,5	15	0,15	0,28	100	180	5	0,2	150
			18,20		250 HB	0,5	15	0,15	0,28	100	150	5	0,2	130
N	Al (>8% Si)	12	25	AlSi12	130 HB	0,5	15	0,18	0,32	200	400	5	0,25	280
S	Heat resistant alloys Warmfeste Legierungen	9	31,32	Incoloy 800	240 HB	0,5	10,7	0,12	0,18	25	45	3,8	0,16	32
			33	Inconel 700	250 HB	0,5	10,7	0,12	0,18	25	45	3,8	0,16	30
			34	Stellite 21	350 HB	0,5	10,7	0,12	0,18	25	45	3,8	0,16	30
	Titanium alloys Titanlegierungen	10	36	TiAl6V4	-	0,5	10,7	0,12	0,2	40	65	3,8	0,18	55
37			T40	-	0,5	10,7	0,12	0,18	30	55	3,8	0,16	40	
H	Steel Stahl	11	38	X100CrMo13,	45 HRc	0,5	5,4	0,1	0,18	40	80	2,5	0,14	60
			38	440C,	50 HRc	0,5	3,2	0,1	0,16	40	70	1,9	0,13	55
			38	G-X260NiCr42	55 HRc	0,5	1,6	0,1	0,14	40	60	1,3	0,12	50
	Chilled cast iron Hartguss	11	40	Ni-Hard 2	400 HB	0,5	4,3	0,1	0,18	40	80	1,9	0,14	50
			41	G-X300CrMo15	55 HRc	0,5	1,6	0,1	0,14	30	60	1,3	0,12	40
	White cast iron Weißguss													

SEKN 1203 AFTN-M A6M-A2, SEKR 1203 AFTN-M A6M-A2, SEKT 1203 AFTN-M A6M-A2

Material group Werkstoffgruppe	Material Werkstoff	Gr. N°	VDI Group VDI Gruppe	Material Examples Material Beispiel	Hardness Härte	D.O.C. [mm]		Feed Vorschub [mm/rev]		Vc [m/min]		Suggested Starting Parameters Empfohlene Beginnend Parameter		
						min	max	min	max	min	max	D.O.C.	Feed	Vc
P	Non alloyed Unlegiert	1	1	C35, Ck45, 1020,	125 HB	0,5	7	0,18	0,46	190	330	3	0,34	250
			2	1045, 1060,	190 HB	0,5	7	0,18	0,46	190	300	3	0,34	220
			3	28Mn6	250 HB	0,5	7	0,18	0,46	190	250	3	0,34	200
	Low alloyed Niedrig legiert	2	6	42CrMo4, St50,	180 HB	0,5	7	0,15	0,36	150	240	3	0,3	200
			4,6	Ck60, 4140, 4340,	230 HB	0,5	7	0,15	0,36	150	210	3	0,3	180
			5,7	100Cr6	280 HB	0,5	7	0,15	0,32	130	190	3	0,27	150
			8		350 HB	0,5	7	0,15	0,32	130	170	3	0,27	140
	High alloyed Hoch legiert	3	10	X40CrMoV5, H13,	220 HB	0,5	5	0,12	0,32	90	150	2,3	0,27	130
			10	M42, D3, S6-5-2,	280 HB	0,5	5	0,12	0,32	90	130	2,3	0,27	120
			11	12Ni19	320 HB	0,5	5	0,12	0,26	60	110	2,3	0,24	100
11				350 HB	0,5	5	0,12	0,26	60	90	2,3	0,24	80	
M	Austenitic Austenitisch	4	14	304, 316,	180 HB	0,5	7	0,15	0,32	190	250	3	0,27	220
			14	X5CrNi18-19	240 HB	0,5	7	0,12	0,29	160	210	3	0,27	190
	Duplex Duplex	5	14	X2CrNi23-4,	290 HB	0,5	5	0,12	0,26	70	130	2,3	0,24	100
			14	S31500	310 HB	0,5	5	0,12	0,26	70	120	2,3	0,24	90
Austenitic hardened Austenitisch gehärtet	6	12	410, X6Cr17,	200 HB	0,5	7	0,15	0,32	150	210	3	0,27	190	
		13	17-4 PH, 430	42 HRc	0,5	5	0,15	0,26	90	150	2,3	0,24	130	
K	Grey cast iron Grauguss	7	15	GG20, GG40,	150 HB	0,5	7	0,18	0,46	150	240	3	0,34	200
			15	EN-GJL-250,	200 HB	0,5	7	0,18	0,46	150	220	3	0,34	180
			16	No30B	250 HB	0,5	7	0,18	0,46	150	190	3	0,34	160
	Nodular graphite cast iron Gusseisen mit Kugelgraphit	8	17,19	GGG40, GGG70,	150 HB	0,5	7	0,15	0,41	100	200	3	0,3	180
			17,19	50005	200 HB	0,5	7	0,15	0,41	100	180	3	0,3	150
			18,20		250 HB	0,5	7	0,15	0,41	100	150	3	0,3	130
N	Al (>8% Si)	12	25	AlSi12	130 HB	0,5	7	0,18	0,46	200	400	3	0,37	280
S	Heat resistant alloys Warmfeste Legierungen	9	31,32	Incoloy 800	240 HB	0,5	5	0,12	0,26	25	45	2,3	0,24	32
			33	Inconel 700	250 HB	0,5	5	0,12	0,26	25	45	2,3	0,24	30
			34	Stellite 21	350 HB	0,5	5	0,12	0,26	25	45	2,3	0,24	30
	Titanium alloys Titanlegierungen	10	36	TiAl6V4	-	0,5	5	0,12	0,29	40	65	2,3	0,27	55
37			T40	-	0,5	5	0,12	0,26	30	55	2,3	0,24	40	
H	Steel Stahl	11	38	X100CrMo13,	45 HRc	0,5	2,5	0,1	0,26	40	80	1,5	0,21	60
			38	440C,	50 HRc	0,5	1,8	0,1	0,23	40	70	1,1	0,19	55
			38	G-X260NiCr42	55 HRc	0,5	1,5	0,1	0,2	40	60	0,8	0,18	50
	Chilled cast iron Hartguss	11	40	Ni-Hard 2	400 HB	0,5	2	0,1	0,26	40	80	1,1	0,21	50
			41	G-X300CrMo15	55 HRc	0,5	1,5	0,1	0,2	30	60	0,8	0,18	40
	White cast iron Weißguss													

SPMT 060304TN-M A6M-A2

Material group Werkstoffgruppe	Material Werkstoff	Gr. N°	VDI Group VDI Gruppe	Material Examples Material Beispiel	Hardness Härte	D.O.C. [mm]		Feed Vorschub [mm/rev]		Vc [m/min]		Suggested Starting Parameters Empfohlene Beginnend Parameter		
						min	max	min	max	min	max	D.O.C.	Feed	Vc
P	Non alloyed Unlegiert	1	1	C35, Ck45, 1020,	125 HB	0,3	6	0,06	0,12	190	330	2,4	0,1	250
			2	1045, 1060,	190 HB	0,3	6	0,06	0,1	190	300	2,4	0,08	220
			3	28Mn6	250 HB	0,3	6	0,06	0,1	190	250	2,4	0,08	200
	Low alloyed Niedrig legiert	2	6	42CrMo4, St50,	180 HB	0,3	6	0,06	0,12	150	240	2,4	0,1	200
			4,6	Ck60, 4140, 4340,	230 HB	0,3	6	0,06	0,1	150	210	2,4	0,08	180
			5,7	100Cr6	280 HB	0,3	6	0,05	0,1	130	190	2,4	0,08	150
			8		350 HB	0,3	6	0,05	0,1	130	170	2,4	0,08	140
	High alloyed Hoch legiert	3	10	X40CrMoV5, H13,	220 HB	0,3	4,3	0,06	0,08	90	150	1,8	0,07	130
			10	M42, D3, S6-5-2,	280 HB	0,3	4,3	0,05	0,1	90	130	1,8	0,08	120
			11	12Ni19	320 HB	0,3	4,3	0,05	0,08	60	110	1,8	0,06	100
			11		350 HB	0,3	4,3	0,05	0,08	60	90	1,8	0,06	80
M	Austenitic Austenitisch	4	14	304, 316,	180 HB	0,3	6	0,06	0,08	190	250	2,4	0,07	220
			14	X5CrNi18-19	240 HB	0,3	6	0,05	0,08	160	210	2,4	0,07	190
	Duplex Duplex	5	14	X2CrNi23-4,	290 HB	0,3	4,3	0,05	0,08	70	130	1,8	0,07	100
			14	S31500	310 HB	0,3	4,3	0,05	0,07	70	120	1,8	0,06	90
Austenitic hardened Austenitisch gehärtet	6	12	410, X6Cr17,	200 HB	0,3	6	0,05	0,08	150	210	2,4	0,07	190	
		13	17-4 PH, 430	42 HRc	0,3	4,3	0,05	0,07	90	150	1,8	0,06	130	
K	Grey cast iron Grauguss	7	15	GG20, GG40,	150 HB	0,3	6	0,05	0,14	150	240	2,4	0,12	200
			15	EN-GJL-250,	200 HB	0,3	6	0,05	0,12	150	220	2,4	0,1	180
			16	No30B	250 HB	0,3	6	0,05	0,12	150	190	2,4	0,1	160
	Nodular graphite cast iron Gusseisen mit Kugelgraphit	8	17,19	GGG40, GGG70,	150 HB	0,3	6	0,05	0,14	100	200	2,4	0,12	180
			17,19	50005	200 HB	0,3	6	0,05	0,12	100	180	2,4	0,1	150
			18,20		250 HB	0,3	6	0,05	0,12	100	150	2,4	0,1	130
N	Al (>8% Si)	12	25	AlSi12	130 HB	0,3	6	0,08	0,14	200	400	2,4	0,12	280
S	Heat resistant alloys Warmfeste Legierungen	9	31,32	Incoloy 800	240 HB	0,3	4,3	0,04	0,08	25	45	1,8	0,06	32
			33	Inconel 700	250 HB	0,3	4,3	0,04	0,08	25	45	1,8	0,06	30
			34	Stellite 21	350 HB	0,3	4,3	0,04	0,08	25	45	1,8	0,06	30
	Titanium alloys Titanlegierungen	10	36	TiAl6V4	-	0,3	4,3	0,04	0,08	40	65	1,8	0,06	55
37			T40	-	0,3	4,3	0,04	0,08	30	55	1,8	0,06	40	
H	Steel Stahl	11	38	X100CrMo13,	45 HRc	0,3	2,1	0,04	0,1	40	80	1,2	0,08	60
			38	440C,	50 HRc	0,3	1,3	0,04	0,08	40	70	0,9	0,06	55
			38	G-X260NiCr42	55 HRc	0,3	0,9	0,04	0,06	40	60	0,6	0,05	50
	Chilled cast iron Hartguss	11	40	Ni-Hard 2	400 HB	0,3	1,7	0,04	0,06	40	80	0,9	0,05	50
			41	G-X300CrMo15	55 HRc	0,3	0,9	0,04	0,06	30	60	0,6	0,05	40
	White cast iron Weißguss													

SPMT 09T308 TN-M A6M-A2

Material group Werkstoffgruppe	Material Werkstoff	Gr. N°	VDI Group VDI Gruppe	Material Examples Material Beispiel	Hardness Härte	D.O.C. [mm]		Feed Vorschub [mm/rev]		Vc [m/min]		Suggested Starting Parameters Empfohlene Beginnend Parameter		
						min	max	min	max	min	max	D.O.C.	Feed	Vc
P	Non alloyed Unlegiert	1	1	C35, Ck45, 1020,	125 HB	0,5	9	0,07	0,17	190	330	2,4	0,15	250
			2	1045, 1060,	190 HB	0,5	9	0,06	0,15	190	300	2,4	0,13	220
			3	28Mn6	250 HB	0,5	9	0,06	0,15	190	250	2,4	0,13	200
	Low alloyed Niedrig legiert	2	6	42CrMo4, St50,	180 HB	0,5	9	0,07	0,17	150	240	2,4	0,15	200
			4,6	Ck60, 4140, 4340,	230 HB	0,5	9	0,06	0,15	150	210	2,4	0,13	180
			5,7	100Cr6	280 HB	0,5	9	0,05	0,13	130	190	2,4	0,11	150
			8		350 HB	0,5	9	0,05	0,13	130	170	2,4	0,11	140
	High alloyed Hoch legiert	3	10	X40CrMoV5, H13,	220 HB	0,5	6,5	0,07	0,15	90	150	1,8	0,13	130
			10	M42, D3, S6-5-2,	280 HB	0,5	6,5	0,05	0,13	90	130	1,8	0,11	120
			11	12Ni19	320 HB	0,5	6,5	0,05	0,1	60	110	1,8	0,08	100
11				350 HB	0,5	6,5	0,05	0,1	60	90	1,8	0,08	80	
M	Austenitic Austenitisch	4	14	304, 316,	180 HB	0,5	9	0,07	0,12	190	250	2,4	0,1	220
			14	X5CrNi18-19	240 HB	0,5	9	0,05	0,1	160	210	2,4	0,08	190
	Duplex Duplex	5	14	X2CrNi23-4,	290 HB	0,5	6,5	0,05	0,1	70	130	1,8	0,08	100
			14	S31500	310 HB	0,5	6,5	0,05	0,08	70	120	1,8	0,07	90
Austenitic hardened Austenitisch gehärtet	6	12	410, X6Cr17,	200 HB	0,5	9	0,05	0,08	150	210	2,4	0,07	190	
		13	17-4 PH, 430	42 HRc	0,5	6,5	0,05	0,08	90	150	1,8	0,07	130	
K	Grey cast iron Grauguss	7	15	GG20, GG40,	150 HB	0,5	9	0,06	0,22	150	240	2,4	0,18	200
			15	EN-GJL-250,	200 HB	0,5	9	0,06	0,22	150	220	2,4	0,18	180
			16	No30B	250 HB	0,5	9	0,06	0,2	150	190	2,4	0,16	160
	Nodular graphite cast iron Gusseisen mit Kugelgraphit	8	17,19	GGG40, GGG70,	150 HB	0,5	9	0,06	0,22	100	200	2,4	0,18	180
			17,19	50005	200 HB	0,5	9	0,05	0,22	100	180	2,4	0,18	150
			18,20		250 HB	0,5	9	0,05	0,2	100	150	2,4	0,16	130
N	Al (>8% Si)	12	25	AlSi12	130 HB	0,5	9	0,08	0,16	200	400	2,4	0,13	280
S	Heat resistant alloys Warmfeste Legierungen	9	31,32	Incoloy 800	240 HB	0,5	6,5	0,04	0,12	25	45	1,8	0,1	32
			33	Inconel 700	250 HB	0,5	6,5	0,04	0,12	25	45	1,8	0,1	30
			34	Stellite 21	350 HB	0,5	6,5	0,04	0,12	25	45	1,8	0,1	30
	Titanium alloys Titanlegierungen	10	36	TiAl6V4	-	0,5	6,5	0,04	0,12	40	65	1,8	0,1	55
37			T40	-	0,5	6,5	0,04	0,12	30	55	1,8	0,1	40	
H	Steel Stahl	11	38	X100CrMo13,	45 HRc	0,5	3,2	0,04	0,12	40	80	1,2	0,1	60
			38	440C,	50 HRc	0,5	1,9	0,04	0,1	40	70	0,9	0,08	55
			38	G-X260NiCr42	55 HRc	0,5	1,3	0,04	0,08	40	60	0,6	0,06	50
	Chilled cast iron Hartguss	11	40	Ni-Hard 2	400 HB	0,5	2,6	0,04	0,08	40	80	0,9	0,06	50
			41	G-X300CrMo15	55 HRc	0,5	1,3	0,04	0,08	30	60	0,6	0,06	40
	White cast iron Weißguss													





SPMT 120408 TN-M A6M-A2

Material group Werkstoffgruppe	Material Werkstoff	Gr. N°	VDI Group VDI Gruppe	Material Examples Material Beispiel	Hardness Härte	D.O.C. [mm]		Feed Vorschub [mm/rev]		Vc [m/min]		Suggested Starting Parameters Empfohlene Beginnend Parameter		
						min	max	min	max	min	max	D.O.C.	Feed	Vc
P	Non alloyed Unlegiert	1	1	C35, Ck45, 1020,	125 HB	0,5	9	0,13	0,29	190	330	3	0,18	250
			2	1045, 1060,	190 HB	0,5	9	0,13	0,29	190	300	3	0,18	220
			3	28Mn6	250 HB	0,5	9	0,13	0,29	190	250	3	0,18	200
	Low alloyed Niedrig legiert	2	6	42CrMo4, St50,	180 HB	0,5	9	0,11	0,23	150	240	3	0,16	200
			4,6	Ck60, 4140, 4340,	230 HB	0,5	9	0,11	0,23	150	210	3	0,16	180
			5,7	100Cr6	280 HB	0,5	9	0,11	0,2	130	190	3	0,14	150
			8		350 HB	0,5	9	0,11	0,2	130	170	3	0,14	140
	High alloyed Hoch legiert	3	10	X40CrMoV5, H13,	220 HB	0,5	6,5	0,08	0,2	90	150	2,3	0,14	130
			10	M42, D3, S6-5-2,	280 HB	0,5	6,5	0,08	0,2	90	130	2,3	0,14	120
			11	12Ni19	320 HB	0,5	6,5	0,08	0,16	60	110	2,3	0,13	100
11				350 HB	0,5	6,5	0,08	0,16	60	90	2,3	0,13	80	
M	Austenitic Austenitisch	4	14	304, 316,	180 HB	0,5	9	0,11	0,23	190	250	3	0,16	220
			14	X5CrNi18-19	240 HB	0,5	9	0,08	0,2	160	210	3	0,16	190
	Duplex Duplex	5	14	X2CrNi23-4,	290 HB	0,5	6,5	0,08	0,16	70	130	2,3	0,13	100
			14	S31500	310 HB	0,5	6,5	0,08	0,16	70	120	2,3	0,13	90
Austenitic hardened Austenitisch gehärtet	6	12	410, X6Cr17,	200 HB	0,5	9	0,11	0,23	150	210	3	0,16	190	
		13	17-4 PH, 430	42 HRC	0,5	6,5	0,11	0,18	90	150	2,3	0,13	130	
K	Grey cast iron Grauguss	7	15	GG20, GG40,	150 HB	0,5	9	0,13	0,29	150	240	3	0,18	200
			15	EN-GJL-250,	200 HB	0,5	9	0,13	0,29	150	220	3	0,18	180
			16	No30B	250 HB	0,5	9	0,13	0,29	150	190	3	0,18	160
	Nodular graphite cast iron Gusseisen mit Kugelgraphit	8	17,19	GGG40, GGG70,	150 HB	0,5	9	0,11	0,25	100	200	3	0,16	180
			17,19	50005	200 HB	0,5	9	0,11	0,25	100	180	3	0,16	150
			18,20		250 HB	0,5	9	0,11	0,25	100	150	3	0,16	130
N	Al (>8% Si)	12	25	AlSi12	130 HB	0,5	9	0,13	0,29	200	400	3	0,2	280
S	Heat resistant alloys Warmfeste Legierungen	9	31,32	Incoloy 800	240 HB	0,5	6,5	0,08	0,16	25	45	2,3	0,13	32
			33	Inconel 700	250 HB	0,5	6,5	0,08	0,16	25	45	2,3	0,13	30
			34	Stellite 21	350 HB	0,5	6,5	0,08	0,16	25	45	2,3	0,13	30
	Titanium alloys Titanlegierungen	10	36	TiAl6V4	-	0,5	6,5	0,08	0,18	40	65	2,3	0,14	55
37			T40	-	0,5	6,5	0,08	0,16	30	55	2,3	0,13	40	
H	Steel Stahl	11	38	X100CrMo13,	45 HRc	0,5	3,2	0,07	0,16	40	80	1,5	0,11	60
			38	440C,	50 HRc	0,5	1,9	0,07	0,14	40	70	1,1	0,1	55
			38	G-X260NiCr42	55 HRc	0,5	1	0,07	0,13	40	60	0,8	0,1	50
	Chilled cast iron Hartguss	11	40	Ni-Hard 2	400 HB	0,5	2,6	0,07	0,16	40	80	1,1	0,11	50
			41	G-X300CrMo15	55 HRc	0,5	1	0,07	0,13	30	60	0,8	0,1	40

SEGT 1204 AFEN-M D1M-B2

Material group Werkstoffgruppe	Material Werkstoff	Gr. N°	VDI Group VDI Gruppe	Material Examples Material Beispiel	Hardness Härte	D.O.C. [mm]		Feed Vorschub [mm/rev]		Vc [m/min]		Suggested Starting Parameters Empfohlene Beginnend Parameter		
						min	max	min	max	min	max	D.O.C.	Feed	Vc
N	Al (<8% Si)	13	21, 22,	Si < 4%	60 HB	0,3	9	0,12	0,35	400	1200	3	0,25	500
			23, 24	4% < Si < 8%	100 HB	0,3	9	0,1	0,35	250	600	3	0,25	400
	Copper alloys Kupferlegierungen	14	26, 27,	CuZn30	100 HB	0,3	9	0,1	0,35	100	800	3	0,25	300
			28											
Non-metallic Nichtmetallische	15	29	Fiber Plastics	-	0,3	9	0,12	0,35	80	500	3	0,2	200	
		30	Hard Rubber	-	0,3	9	0,12	0,35	80	300	3	0,2	150	
		-	Graphite	-	0,3	9	0,12	0,35	100	200	3	0,2	150	
S	Titanium alloys Titanlegierungen	10	36	Ti 1	-	0,3	5	0,08	0,35	35	60	2	0,2	45
			37	TiAl 6 V4	-	0,3	5	0,08	0,28	28	45	2	0,2	35

Cutting data recommendations for HS A31-A1
 Schnittwertempfehlungen für Drehen HS A31-A1

Material Group Werkstoffgruppe	Material Werkstoff	Brinell Hardness Brinell Härte HB	Cutting speed Schnittgeschwindigkeit v _c [m/min]			
			HS A31-A1			
			f [mm/rev]			
			0,4–0,8	0,25–0,4	0,05–0,25	
						
P	Unalloyed steel ¹⁾ Unlegierter Stahl ¹⁾	≈ 0,15% C annealed gegläht	125	140–200	230–300	290–360
		≈ 0,45% C annealed gegläht	190	110–180	180–260	250–320
		≈ 0,45% C hardened and temp. vergütet	250	90–180	110–180	140–210
		≈ 0,75% C annealed gegläht	270	120–180	170–240	230–300
		≈ 0,75% C hardened and temp. vergütet	300	130–150	80–150	140–210
	Low-alloy steel ¹⁾ Niedrig legierter Stahl ¹⁾	Annealed Geglüht	180	100–170	150–220	220–300
		Hardened and temp. Vergütet	275	100–150	110–180	140–210
		Hardened and temp. Vergütet	300	100–140	100–170	130–200
		Hardened and temp. Vergütet	350	100–140	80–150	110–180
	High-alloy steel and high alloy tool steel ¹⁾ Hochlegierter Stahl und hochlegierter Werkzeugstahl ¹⁾	Annealed Geglüht	200	100–180	80–220	180–260
		Hardened and temp. Vergütet	325	100–160	80–140	100–170
	Stainless steel ¹⁾ Nichtrostender Stahl ¹⁾	Ferritic/martensitic annealed Ferritisch/martensitisch gegläht	200	100–170	130–200	180–260
		Martensitic hardened and temp. Martensitisch vergütet	240	100–140	80–150	150–210
	K	Grey cast iron Grauguss	Perlitic/ferritic Perlitisch/ferritisch	180	100–180	170–240
Perlitic (martensitic) Perlitisch (martensitisch)			260	90–120	80–150	110–180
Nodular graphite cast iron Gusseisen mit Kugelgraphit		Ferritic Ferritisch	160	100–150	110–180	140–210
		Perlitic Perlitisch	250	90–140	90–160	110–180
Malleable cast iron Temperguss		Ferritic Ferritisch	130	90–140	120–190	150–210
		Perlitic Perlitisch	230	90–120	100–150	110–180





¹⁾ and cast steel und Stahlguss

Without coolant Trockenbearbeitung



With coolant Nassbearbeitung

Cutting data recommendations for A51-B1
 Schnittwertempfehlungen für Drehen A51-B1

Material Group Werkstoffgruppe	Material Werkstoff	Brinell Hardness Brinell Härte HB	Cutting speed Schnittgeschwindigkeit v _c [m/min]			
			A51-B1			
			f [mm/rev]			
			0,4–0,8	0,25–0,4	0,05–0,25	
						
P	Unalloyed steel ¹⁾ Unlegierter Stahl ¹⁾	≈ 0,15% C annealed geglüht	125	120–190	170–250	170–250
		≈ 0,45% C annealed geglüht	190	100–180	150–200	150–220
		≈ 0,45% C hardened and temp. vergütet	250	80–150	100–170	120–200
		≈ 0,75% C annealed geglüht	270	100–170	80–140	140–200
		≈ 0,75% C hardened and temp. vergütet	300	70–140	100–160	100–170
	Low-alloy steel ¹⁾ Niedrig legierter Stahl ¹⁾	Annealed Geglüht	180	90–160	140–200	140–200
		Hardened and temp. Vergütet	275	90–140	100–160	100–180
		Hardened and temp. Vergütet	300	85–130	100–150	100–170
		Hardened and temp. Vergütet	350	80–120	80–140	90–170
	High-alloy steel and high alloy tool steel ¹⁾ Hochlegierter Stahl und hochlegierter Werkzeugstahl ¹⁾	Annealed Geglüht	200	90–150	80–170	130–170
		Hardened and temp. Vergütet	325	50–110	70–130	80–130
	Stainless steel ¹⁾ Nichtrostender Stahl ¹⁾	Ferritic/martensitic annealed Ferritisch/martensitisch geglüht	200	90–140	120–180	140–180
		Martensitic hardened and temp. Martensitisch vergütet	240	85–120	80–140	100–140
M	Stainless steel ¹⁾ Nichtrostender Stahl ¹⁾	Austenitic ²⁾ , quenched Austenitisch ²⁾ , abgeschreckt	180	90–110	100–130	100–130

¹⁾ and cast steel und Stahlguss







²⁾ and austenitic/ferritic und austenitische/ferritische

Without coolant Trockenbearbeitung



With coolant Nassbearbeitung

Cutting data recommendations for IC A81-C1
 Schnittwertempfehlungen für Drehen IC A81-C1

Material Group Werkstoffgruppe	Material Werkstoff	Brinell Hardness Brinell Härte HB	Cutting speed Schnittgeschwindigkeit v _c [m/min]					
			IC A81-C1					
			f [mm/rev]					
			0,4–0,8	0,25–0,4	0,05–0,25			
								
P	Unalloyed steel ¹⁾ Unlegierter Stahl ¹⁾	≈ 0,15% C annealed geglüht	125	60–100	70–110	90–170		
		≈ 0,45% C annealed geglüht	190	60–100	70–110	90–170		
		≈ 0,45% C hardened and temp. vergütet	250	60–100	70–110	90–170		
		≈ 0,75% C annealed geglüht	270	60–100	70–110	90–170		
		≈ 0,75% C hardened and temp. vergütet	300	60–100	70–110	90–170		
	Low-alloy steel ¹⁾ Niedrig legierter Stahl ¹⁾	Annealed Geglüht	180	60–100	70–110	90–170		
		Hardened and temp. Vergütet	275	70–110	70–110	90–170		
		Hardened and temp. Vergütet	300	60–100	70–110	90–170		
		Hardened and temp. Vergütet	350	55–80	70–110	90–170		
	High-alloy steel and high alloy tool steel ¹⁾ Hochlegierter Stahl und hochlegierter Werkzeugstahl ¹⁾	Annealed Geglüht	200	80–110	70–110	90–170		
		Hardened and temp. Vergütet	325	60–90	70–110	90–170		
	Stainless steel ¹⁾ Nichtrostender Stahl ¹⁾	Ferritic/martensitic annealed Ferritisch/martensitisch geglüht	200	90–130	70–110	90–170		
		Martensitic hardened and temp. Martensitisch vergütet	240	70–110	70–110	90–170		
	M	Stainless steel ¹⁾ Nichtrostender Stahl ¹⁾	Austenitic ²⁾ , quenched Austenitisch ²⁾ , abgeschreckt	180	70–100	90–140	110–170	

¹⁾ and cast steel und Stahlguss

²⁾ and austenitic/ferritic und austenitische/ferritische

Without coolant Trockenbearbeitung



With coolant Nassbearbeitung

Cutting data recommendations for B41-D1
 Schnittwertempfehlungen für Drehen B41-D1

Material Group Werkstoffgruppe	Material Werkstoff	Brinell Hardness HB	B41-D1										
			Negative indexable inserts Negative Wendepplatten ISO-P-System						Positive indexable inserts Positive Wendepplatten ISO-S-System				
			Geometry Geometrie	Corner radius Eckenradius	Recommended a_p [mm] Empfohlene a_p [mm]	Recommended f_n [mm/rev] Empfohlene f_n [mm/U]	Cutting speed Schnittgeschwindigkeit v_c [m/min]	Geometry Geometrie	Corner radius Eckenradius	Recommended a_p [mm] Empfohlene a_p [mm]	Recommended f_n [mm/rev] Empfohlene f_n [mm/U]	Cutting speed Schnittgeschwindigkeit v_c [m/min]	
M	Ferritic Ferritisch	1.4000, 1.4002, 1.4003, 1.4006, 1.4016, 1.4104, 1.4113, 1.4313, 1.4742, 1.4762	180	M1	08	2	0,20	180–230	M1	04	1	0,15	180–230
					12	3	0,30	180–230		08	2	0,25	180–230
	Martensitic Martensitisch	1.4006, 1.4014, 1.4021, 1.4024, 1.4027, 1.4028, 1.4031, 1.4034, 1.4057, 1.4122, 1.4724	320	M1	08	2	0,20	180–230	M1	04	1	0,15	180–230
					12	3	0,30	180–230		08	2	0,25	180–230
	Austenitic Austenitisch	1.4300, 1.4301, 1.4303, 1.4305, 1.4306, 1.4308, 1.4310, 1.4311	180	M1	08	2	0,2	150–200	M1	04	1	0,15	150–200
					12	3	0,3	150–200		08	2	0,20	150–200
		1.4321, 1.4401, 1.4404, 1.4406, 1.4428, 1.4435, 1.4436, 1.4438, 1.4449, 1.4571	180	M1	08	2	0,2	150–200	M1	04	0,4	1	150–200
					12	3	0,3	150–200		08	0,8	2	150–200

The above recommendations are given for wet machining. For dry machining the recommended values for the cutting speed have to be reduced by approx. 20%.

Die angegebenen Schnittdatenrichtwerte sind Empfehlungen für Anwendungen mit Kühlschmierstoff. Bei Trockenbearbeitung reduzieren Sie die Schnittgeschwindigkeit v_c um ca. 20%.

Cutting data recommendations for B51-E1
 Schnittwertempfehlungen für Drehen B51-E1

Material Group Werkstoffgruppe	Material Werkstoff	Brinell Hardness Brinell Härte HB	B51-E1											
			Negative indexable inserts Negative Wendepplatten ISO-P-System						Positive indexable inserts Positive Wendepplatten ISO-S-System					
			Geometry Geometrie	Corner radius Eckenradius	Recommended a_p [mm] Empfohlene a_p [mm]	Recommended f_n [mm/rev] Empfohlene f_n [mm/U]	Cutting speed Schnittgeschwindigkeit v_c [m/min]	Geometry Geometrie	Corner radius Eckenradius	Recommended a_p [mm] Empfohlene a_p [mm]	Recommended f_n [mm/rev] Empfohlene f_n [mm/U]	Cutting speed Schnittgeschwindigkeit v_c [m/min]		
M	Ferritic Ferritisch	1.4000, 1.4002, 1.4003, 1.4006, 1.4016, 1.4104, 1.4113, 1.4313, 1.4742, 1.4762	180	M1	08	2	0,2	130–200	M1	04	1	0,15	130–200	
					12	3	0,3	130–200		08	2	0,25	130–200	
					16	3,5	0,3	130–200						
				FM	04	1	0,15	130–200						
					08	2,5	0,25	130–200						
					12	3	0,3	130–200						
				M	08	2	0,2	130–200						
					12	3	0,3	130–200						
	Martensitic Martensitisch	1.4006, 1.4014, 1.4021, 1.4024, 1.4027, 1.4028, 1.4031, 1.4034, 1.4057, 1.4122, 1.4724	320	M1	08	2	0,2	130–200	M1	04	1	0,15	130–200	
					12	3	0,3	130–200		08	2	0,25	130–200	
					16	3,5	0,3	130–200						
					FM	04	1	0,15	130–200					
						08	2,5	0,25	130–200					
						12	3	0,3	130–200					
					M	08	2	0,2	130–200					
						12	3	0,3	130–200					
											Cutting			
	Austenitic Austenitisch	1.4300, 1.4301, 1.4303, 1.4305, 1.4306, 1.4308, 1.4310, 1.4311	180	M1	08	2	0,2	100–180	M1	04	1	0,15	100–180	
					12	3	0,3	100–180		08	2	0,20	100–180	
					16	3,5	0,3	100–180						
					FM	04	1	0,15	100–180					
						08	2,5	0,25	100–180					
						12	3	0,3	100–180					
				M	08	2	0,2	100–180						
					12	3	0,3	100–180						
1.4321, 1.4401, 1.4404, 1.4406, 1.4428, 1.4435, 1.4436, 1.4438, 1.4449, 1.4571		180	M1	08	2	0,2	100–180	M1	04	1	0,15	100–180		
				12	3	0,3	100–180		08	2	0,2	100–180		
				16	3,5	0,3	100–180							
				FM	04	1	0,15	100–180						
					08	2,5	0,25	100–180						
					12	3	0,3	100–180						
				M	08	2	0,2	100–180						
	12	3	0,3		100–180									

The above recommendations are given for wet machining. For dry machining the recommended values for the cutting speed have to be reduced by approx. 20%.

Die angegebenen Schnittdatenrichtwerte sind Empfehlungen für Anwendungen mit Kühlschmierstoff. Bei Trockenbearbeitung reduzieren Sie die Schnittgeschwindigkeit v_c um ca. 20%.



Cutting data recommendations for B71-G1
 Schnittwertempfehlungen für Drehen B71-G1

Material Group Werkstoffgruppe	Material Werkstoff	Brinell Hardness HB	B71-G1											
			Negative indexable inserts Negative Wendeplatten ISO-P-System					Positive indexable inserts Positive Wendeplatten ISO-S-System						
			Geometry Geometrie	Corner radius Eckenradius	Recommended a_p [mm] Empfohlene a_p [mm]	Recommended f_n [mm/rev] Empfohlene f_n [mm/U]	Cutting speed Schnittgeschwindigkeit v_c [m/min]	Geometry Geometrie	Corner radius Eckenradius	Recommended a_p [mm] Empfohlene a_p [mm]	Recommended f_n [mm/rev] Empfohlene f_n [mm/U]	Cutting speed Schnittgeschwindigkeit v_c [m/min]		
M	Ferritic Ferritisch	1.4000, 1.4002, 1.4003, 1.4006, 1.4016, 1.4104, 1.4113, 1.4313, 1.4742, 1.4762	180	MF	04	0,5	0,15	150-180						
					08	1	0,20	150-180						
					12	2	0,25	120-180						
			M	08	2	0,25	150-180	MR1	04	0,4	0,15	120-180		
				12	3	0,30	150-180		08	1	0,20	140-180		
				16	4	0,35	120-180							
			MR	08	3	0,35	140-180							
				12	4	0,45	140-180							
				16	5	0,50	120-160							
	Martensitic Martensitisch	1.4006, 1.4014, 1.4021, 1.4024, 1.4027, 1.4028, 1.4031, 1.4034, 1.4057, 1.4122, 1.4724	320	MF	04	0,5	0,15	140-180						
					08	1	0,20	120-180						
					12	2	0,25	110-160						
				M	08	2	0,25	120-180	MR1	04	0,4	0,15	140-180	
					12	3	0,30	110-160		08	1	0,20	120-180	
					16	4	0,35	100-140						
				MR	08	3	0,35	110-160						
					12	4	0,45	100-140						
					16	5	0,50	90-130						
	Austenitic Austenitisch	1.4300, 1.4301, 1.4303, 1.4305, 1.4306, 1.4308, 1.4310, 1.4311	180	MF	04	0,5	0,15	150-180						
					08	1	0,20	150-180						
					12	2	0,25	120-180						
				M	08	2	0,25	120-180	MR1	04	0,4	0,15	120-150	
					12	3	0,30	120-180		08	1	0,20	150-180	
					16	4	0,35	140-180						
MR				08	3	0,35	150-180							
				12	4	0,45	140-180							
				16	5	0,50	120-160							
1.4321, 1.4401, 1.4404, 1.4406, 1.4428, 1.4435, 1.4436, 1.4438, 1.4449		180	MF	04	0,5	0,15	150-180							
				08	1	0,20	140-180							
				12	2	0,25	130-180							
			M	08	2	0,25	140-180	MR1	04	0,4	0,15	150-180		
				12	3	0,30	130-180		08	1	0,20	120-180		
				16	4	0,35	120-160							
MR	08	3	0,35	130-180										
	12	4	0,45	120-160										
	16	5	0,50	100-140										

The above recommendations are given for wet machining. For dry machining the recommended values for the cutting speed have to be reduced by approx. 20%.

Die angegebenen Schnittdatenrichtwerte sind Empfehlungen für Anwendungen mit Kühlschmierstoff. Bei Trockenbearbeitung reduzieren Sie die Schnittgeschwindigkeit v_c um ca. 20%.

Cutting data recommendations for C21-I1 and HS C31-J1
 Schnittwertempfehlungen für Drehen C21-I1 und HS C31-J1

Material Group Werkstoffgruppe	Material Werkstoff		Brinell Hardness Brinell Härte HB	Cutting speed Schnittgeschwindigkeit v_c [m/min]		
				C21-I1, HS C31-J1		
				f [mm/rev]		
				0,4–0,8	0,25–0,4	0,05–0,25
						
K	Grey cast iron Grauguss	Perlitic/ferritic Perlitisch/ferritisch	180	210–300	300–450	350–500
		Perlitic (martensitic) Perlitisch (martensitisch)	260	140–200	170–240	190–270
	Nodular graphite cast iron Gusseisen mit Kugelgraphit	Ferritic Ferritisch	160	150–210	180–260	210–300
		Perlitic Perlitisch	250	110–160	130–190	150–200
	Malleable cast iron Temperguss	Ferritic Ferritisch	130	200–280	220–300	240–330
		Perlitic Perlitisch	230	100–150	140–220	170–240



Without coolant Trockenbearbeitung



With coolant Nassbearbeitung

Minimill

Minifräsen



<p>59</p> <p>Milling Cutters for Chamfering 30°, 45°, 60° Fräser zum Fasen 30°, 45°, 60° CH19-..., CH20-..., CH21-... 59</p>	<p>59</p> <p>Milling Cutters for Chamfering 45° Fräser zum Fasen 45° CH23-... 59</p>	<p>60</p> <p>Milling Cutters for Chamfering-Flaring 10° to 80° Fasenfräser, Winkelverstellbar von 10° bis 80° CH25-... 60</p>
<p>61</p> <p>T Slot Milling Cutter Fräser für T-nuten TS26-... 61</p>	<p>62</p> <p>Drilling Endmill Bohrnutfräser DE27-... 62</p>	<p>63</p> <p>Spot Facing and Boring Milling Cutters Senkfräser und Ausbohrer SF28-... 63</p>
<p>64</p> <p>180° Spot-Facing End Mills Senkfräser 180° SF29-... 64</p>	<p>65</p> <p>180° Back Facing Milling Cutters Rückwärtssenker 180° SF30-... 65</p>	<p>66</p> <p>Adjustement Boring Bars Einstellbare Feinbohrstangen AB31-..., AB32-... 66</p>
<p>67</p> <p>Chamfering Milling Cutters Fasenfräser CH33-... 67 CH34-... 67</p>		

CH19-..., CH20-..., CH21-...

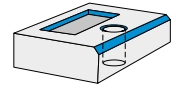
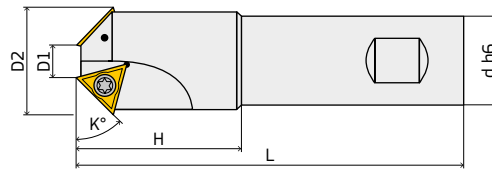

Ordering Code Bestellbezeichnung	Dimensions [mm] Abmessungen [mm]							Weight [kg] Gewicht [kg]	Spare Parts Ersatzteile		
	D1	D2	L	H	dh6	Y°	Z				
45°											
CH19-016.01.45.11.2-0.1	1,2	16	70	20	12	45°	1	0,060	TCMT 1102 ...	VT25	BT08
CH19-021.02.45.11.2-0.1	6,2	21	90	35	20	45°	2	0,180			
CH19-0325.02.45.16.2-0.1	10,4	32,5	100	42	25	45°	2	0,380			
60°											
CH20-016.01.60.11.2-0.1	5,4	16	70	20	12	60°	1	0,060	TCMT 1102 ...	VT25	BT08
CH20-026.02.60.11.2-0.1	15,8	26	90	35	20	60°	2	0,180			
CH20-035.02.60.16.2-0.1	20	35	100	39	25	60°	2	0,380			
30°											
CH21-032.02.30.16.2-0.1	6	32	100	38	25	30°	2	0,380	TCMT 16T3 ...	VT40	BT15

Milling Cutters for Chamfering 45°

Fräser zum Fasen 45°

CH23-...

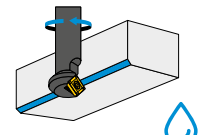
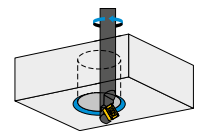
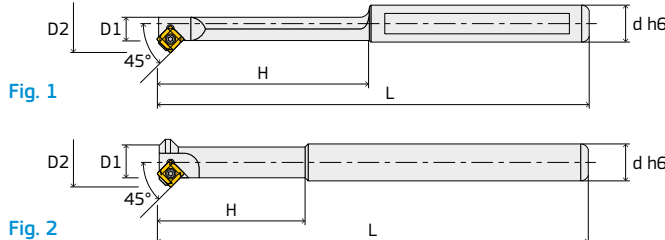

Ordering Code Bestellbezeichnung	Dimensions [mm] Abmessungen [mm]							Weight [kg] Gewicht [kg]	Spare Parts Ersatzteile		
	Fig.	D1	D2	L	H	dh6	Z				
CH23-004.01.45.06.2-0.1	1	4	10	80	28	12	1	0,060	SCMT 0602 ...	VT25	BT08
CH23-011.02.45.06.2-0.1	2	11	20	80	32	12	2	0,070			
CH23-012.01.45.09.2-0.1	1	12	23,7	100	37	20	1	0,190	SCMT 09T3 ...	VT40	BT15
CH23-016.02.45.09.2-0.1	2	16	28,8	100	32	16	2	0,150			
CH23-025.03.45.09.2-0.1	2	30	42,3	100	32	20	3	0,270			
Long models Lange Ausführung											
CH23-012L.01.45.09.2-0.1	1	12	23,7	200	37	20	1	0,420	SCMT 09T3 ...	VT40	BT15
CH23-016L.02.45.09.2-0.1	2	16	28,8	200	32	16	2	0,300			
CH23-025L.03.45.09.2-0.1	2	30	42,3	200	32	20	3	0,480			



Without coolant Trockenbearbeitung



With coolant Nassbearbeitung

CH25-...



Fig. 1

With poket TCMT 16T3 ...
Mit Kassette TCMT 16T3 ...

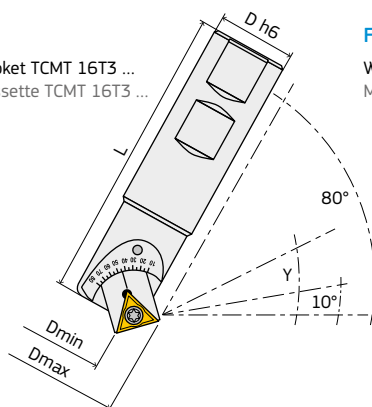
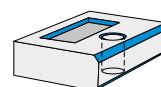
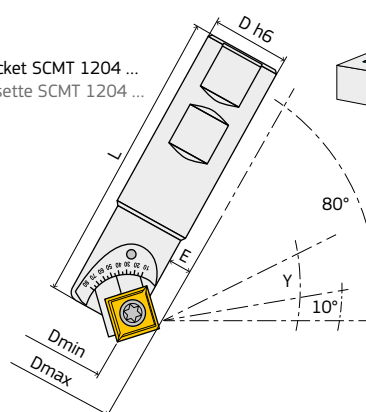

Fig. 2

With pocket SCMT 1204 ...
Mit Kassette SCMT 1204 ...



Ordering Code Bestellbezeichnung	Dimensions [mm] Abmessungen [mm]								Weight [kg] Gewicht [kg]
	D h6	L	Y	Fig. 1		Fig. 2			
				Dmin	Dmax	Dmin	Dmax	E	
CH25-020.01.1080.XX.2-0.1	20	95	-	-	-	-	-	-	0,320
CH25-025.01.1080.XX.2-0.1	25	95	10°	5	32	7,5	30	2,7	0,330
			20°	6	33	10	32	3,6	
			30°	7	34	13	32,5	4,3	
			40°	10	33	16,5	33,5	4,5	
			45°	11	33	17,5	33,5	4,6	
			50°	13	32	19	33,5	4,6	
			60°	16	31	22	33,5	4,3	
			70°	19	29	24,5	33,5	3,8	
80°	23	27	27	31	3				
CH25-025L.01.1080.XX.2-0.1	25	145	-	-	-	-	-	-	0,530
CH25-025XL.01.1080.XX.2-0.1	25	195	-	-	-	-	-	-	0,720

Spare Parts Ersatzteile

Pocket Plattensitz	Insert Wendeschneidplatte	Insert screw Spannschraube	Pocket screw Plattensitz Schraube	Key Schlüssel
T16NEW	TCMT16T3 ...	VT40	M6-16	BT15

Spare Parts Ersatzteile

Pocket Plattensitz	Insert Wendeschneidplatte	Insert screw Spannschraube	Pocket screw Plattensitz Schraube	Key Schlüssel
S12NEW	SCMT1204 ...	VT40S	M6-16	BT20

Without coolant Trockenbearbeitung

With coolant Nassbearbeitung

TS26-...

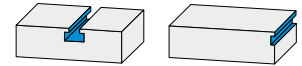
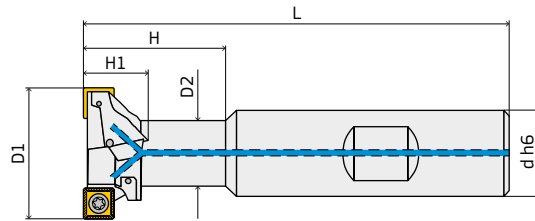

NOTE

For "T" slot cutters according to
DIN 650-UNI4788-ISO 299 norms
Für „T“ Nuten nach DIN 650-
-UNI4788-ISO 299 Normen



Ordering Code Bestellbezeichnung	Dimensions [mm] Abmessungen [mm]								Weight [kg] Gewicht [kg]	Spare Parts Ersatzteile		
	D1	D2	L	H	H1	dh6	K	Z				
TS26-021.02.90.06.2-0	21	11	76	26	9	16	1	2	0,100	SPMT 060304	VT25	BT08
TS26-025.04.90.06.2-0	25	13	82	31	11	16	2	4	0,100			
TS26-032.04.90.09.2-0	32	17	88	38	14	20	2	4	0,200	SPMT 09T308	VT35S	BT15
TS26-040.04.90.09.2-0	40	21	108	50	17	25	2	4	0,400			
TS26-050.04.90.12.2-0	50	27	120	56	22	32	2	4	0,670	SPMT 120408	VT50	BT20

ae/D	1 100%	0,5 50%	0,2 20%	0,1 10%	0,05 5%	0,02 2%
K_{ae}	1	1	1,5	2,1	3	4,8

- v_c [m/min] Cutting speed Schnittgeschwindigkeit
- n [rev/min] Number of revolutions Spindelgeschwindigkeit
- f_z [mm] Tooth feed Zahn Vorschub
- f_n [mm] Feed / Revolution Vorschub / Umdrehung
- v_f [mm/min] Feed speed Vorschub Geschwindigkeit
- K_{ae}** Correction factor Korrektur faktor
- F** Finishing, light machining Schlichten Bearbeitung
- M** Medium machining, generic Mittlere Bearbeitung
- R** Roughing, heavy machining Schruppen Bearbeitung
- Z** Number of flutes Schraubenzahl
- K** Factor of feed Vorschubfaktor
- a_e Radial cutting depth Eingriffsberite



ae/D	0,5-1 50-100%	0,2 20%	0,1 10%	0,05 5%
v_c	v_c (min) ————— v_c (max)			
	R ————— M ————— F			

Without coolant Trockenbearbeitung

With coolant Nassbearbeitung

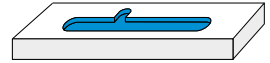
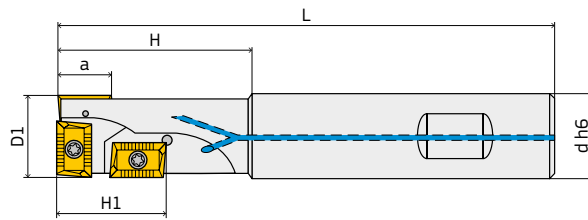
DE27-...







Ordering Code Bestellbezeichnung	Dimensions [mm] Abmessungen [mm]							Weight [kg] Gewicht [kg]	Spare Parts Ersatzteile		
	D1	dh6	L	H	H1	a	Z				
DE27-020.03.90.10.2-1	20	20	90	35	17	9	3	0,200	APKT 1003 ...	VT25	BT08
DE27-025.03.90.10.2-1	25	25	110	50	19	9	3	0,360			
DE27-032.03.90.16.2-1	32	32	130	50	30	15	3	0,720	APKT 1604 ...	VT40	BT15
Long models Lange Ausführung											
DE27-020L.03.90.10.2-1	20	20	150	30	17	9	3	0,320	APKT 1003 ...	VT25	BT08
DE27-025L.03.90.10.2-1	25	25	150	50	19	9	3	0,500			
Long models Lange Ausführung											
DE27-020XL.03.90.10.2-1	20	20	180	30	17	9	3	0,390	APKT 1003 ...	VT25	BT08
DE27-025XL.03.90.10.2-1	25	25	200	50	19	9	3	0,680			
DE27-032XL.03.90.16.2-1	32	32	220	50	30	15	3	1,250	APKT 1604 ...	VT40	BT15

 Without coolant Trockenbearbeitung

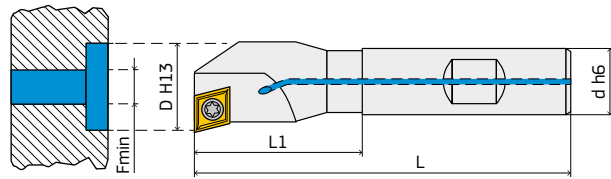
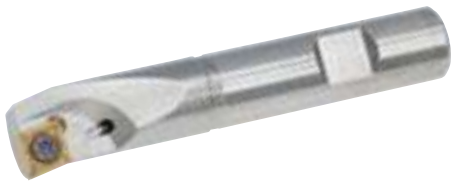
 With coolant Nassbearbeitung

SF28-...



Ordering Code Bestellbezeichnung	Dimensions [mm] Abmessungen [mm]						Weight [kg] Gewicht [kg]	Spare Parts Ersatzteile					
	D	L	L1	dh6	Fmin	Z							
SF28-010.01.90.06.2-0.1	10	85	15	12	4	1	0,060	CCMT 060204	VT25	BT08			
SF28-011.01.90.06.2-0.1	11	85	15	12	4	1	0,060						
SF28-012.01.90.06.2-0.1	12	85	18	12	4	1	0,070						
SF28-013.01.90.06.2-0.1	13	85	23	12	5	1	0,070						
SF28-014.01.90.06.2-0.1	14	85	23	12	5	1	0,070						
SF28-015.01.90.06.2-0.1	15	85	30	12	5	1	0,070						
SF28-016.01.90.09.2-0.1	16	85	30	12	5	1	0,070						
SF28-017.01.90.09.2-0.1	17	95	30	16	6	1	0,120				CCMT 09T304	VT40	BT15
SF28-018.01.90.09.2-0.1	18	95	40	16	6	1	0,120						
SF28-019.01.90.09.2-0.1	19	95	40	16	6	1	0,130						
SF28-020.01.90.09.2-0.1	20	95	40	16	5	1	0,140						
SF28-021.01.90.09.2-0.1	21	95	42	16	5	1	0,140						
SF28-022.01.90.09.2-0.1	22	95	42	16	6	1	0,140						
SF28-023.01.90.09.2-0.1	23	95	42	16	6	1	0,170						
SF28-024.01.90.09.2-0.1	24	95	42	16	6	1	0,280						
SF28-025.01.90.09.2-0.1	25	95	42	16	8	1	0,300						
SF28-026.01.90.09.2-0.1	26	120	56	20	8	1	0,300						
SF28-027.01.90.09.2-0.1	27	120	56	20	8	1	0,310						
SF28-028.01.90.09.2-0.1	28	120	56	20	10	1	0,320						
SF28-029.01.90.09.2-0.1	29	120	56	20	10	1	0,320						
SF28-030.01.90.09.2-0.1	30	120	56	20	10	1	0,340						
SF28-031.01.90.09.2-0.1	31	120	56	20	12	1	0,360						
SF28-032.01.90.09.2-0.1	32	120	56	20	12	1	0,360						
SF28-033.01.90.09.2-0.1	33	120	56	20	12	1	0,360						







Without coolant Trockenbearbeitung

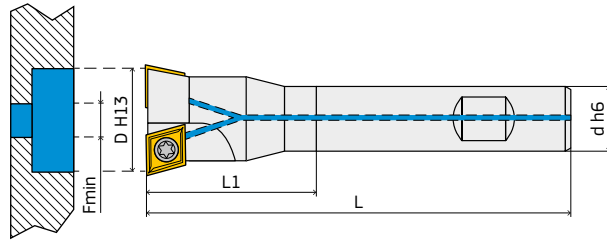

With coolant Nassbearbeitung

SF29-...



Ordering Code Bestellbezeichnung	Dimensions [mm] Abmessungen [mm]							Weight [kg] Gewicht [kg]	Spare Parts Ersatzteile				
	D	L	L1	dh6	Fmin	Z							
SF29-015.02.180.06.2-0.1	15	92	30	12	5	2	0,070	CCMT 060204	VT25	BT08			
SF29-016.02.180.06.2-0.1	16	92	30	12	5	2	0,070						
SF29-017.02.180.06.2-0.1	17	94	32	16	6	2	0,120						
SF29-0175.02.180.06.2-0.1	17,5	96	40	16	6,5	2	0,120						
SF29-018.02.180.06.2-0.1	18	97	41	16	7	2	0,120						
SF29-019.02.180.06.2-0.1	19	100	41	16	8	2	0,130						
SF29-020.02.180.06.2-0.1	20	102	41	16	9	2	0,140						
SF29-021.02.180.06.2-0.1	21	105	41	16	10	2	0,150						
SF29-022.02.180.06.2-0.1	22	110	41	16	11	2	0,160						
SF29-023.02.180.06.2-0.1	23	112	41	16	12	2	0,170						
SF29-024.02.180.06.2-0.1	24	115	41	16	13	2	0,180						
SF29-025.02.180.09.2-0.1	25	120	40	16	8	2	0,180				CCMT 09T304	VT40	BT15
SF29-026.02.180.09.2-0.1	26	125	55	20	9	2	0,270						
SF29-027.02.180.09.2-0.1	27	128	55	20	10	2	0,300						
SF29-028.02.180.09.2-0.1	28	130	55	20	11	2	0,310						
SF29-029.02.180.09.2-0.1	29	132	55	20	12	2	0,330						
SF29-030.02.180.09.2-0.1	30	134	55	20	13	2	0,340						
SF29-031.02.180.09.2-0.1	31	136	55	20	14	2	0,350						
SF29-032.02.180.09.2-0.1	32	138	55	20	15	2	0,370						
SF29-033.02.180.09.2-0.1	33	140	55	20	16	2	0,390						
SF29-034.02.180.09.2-0.1	34	140	60	25	16	2	0,540						
SF29-035.02.180.09.2-0.1	35	140	60	25	17	2	0,550						
SF29-036.02.180.09.2-0.1	36	140	60	25	18	2	0,560						
SF29-037.02.180.09.2-0.1	37	140	60	25	19	2	0,580						
SF29-038.02.180.09.2-0.1	38	140	60	25	20	2	0,590						
SF29-039.02.180.09.2-0.1	39	140	60	25	21	2	0,610						
SF29-040.02.180.09.2-0.1	40	140	60	25	22	2	0,620						
SF29-041.02.180.09.2-0.1	41	140	60	25	23	2	0,640						
SF29-042.02.180.09.2-0.1	42	140	60	25	24	2	0,650	CCMT 120404	VT50	BT20			
SF29-043.02.180.12.2-0.1	43	150	70	25	24	2	0,670						
SF29-044.02.180.12.2-0.1	44	150	70	25	24	2	0,690						
SF29-045.02.180.12.2-0.1	45	150	70	25	24	2	0,700						
SF29-046.02.180.12.2-0.1	46	150	70	25	24	2	0,720						
SF29-047.02.180.12.2-0.1	47	150	70	25	24	2	0,740						
SF29-048.02.180.12.2-0.1	48	150	70	25	24	2	0,760						



Without coolant Trockenbearbeitung



With coolant Nassbearbeitung

SF30-...

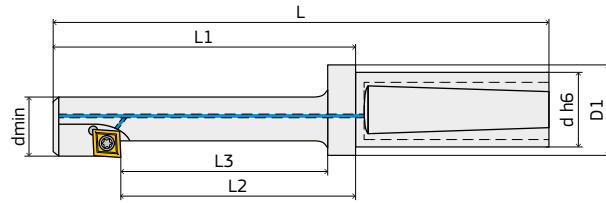

Ordering Code Bestellbezeichnung	Dimensions [mm] Abmessungen [mm]									Weight [kg] Gewicht [kg]	Spare Parts Ersatzteile		
	D	Dmin	L	l1	L2	L3	dh6	D1	e				
SF30-018NC.01.90.06.2-0.1	18	10,5	112	62	47	40	20	25	4	0,170	CCMT 060204	VT25	BT08
SF30-020.01.90.06.2-0.1	20	13	117	67	52	45	20	25	3,75	0,180			
SF30-024.01.90.06.2-0.1	24	15	122	72	57	50	20	25	4,75	0,190			
SF30-026.01.90.06.2-0.1	26	17	132	82	67	60	20	25	5	0,210			
SF30-030.01.90.06.2-0.1	30	19	142	92	77	65	20	25	6	0,250			
SF30-033.01.90.09.2-0.1	33	21	152	102	82	75	20	25	6,5	0,270	CCMT 09T304	VT40	BT15
SF30-036.01.90.09.2-0.1	36	23	173	113	93	85	32	40	7	0,630			
SF30-040.01.90.09.2-0.1	40	25	183	123	103	95	32	40	8	0,670			
SF30-043.01.90.09.2-0.1	43	30	183	123	103	95	32	40	7	0,860	CCMT 120404	VT50	BT20
SF30-048.01.90.09.2-0.1	48	33	223	163	143	135	32	40	8	1,120			
SF30-053.01.90.12.2-0.1	53	36	210	140	-	110	40	-	9	1,420			
SF30-057.01.90.12.2-0.1	57	39	220	150	-	120	40	-	9,5	1,620			
SF30-066.01.90.12.2-0.1	66	45	245	165	-	135	50	-	11	2,620			
SF30-076.01.90.12.2-0.1	76	52	265	185	-	155	50	-	12,5	3,250			

ve = 50-80 m/min
f = 0,08-0,1 mm/rev

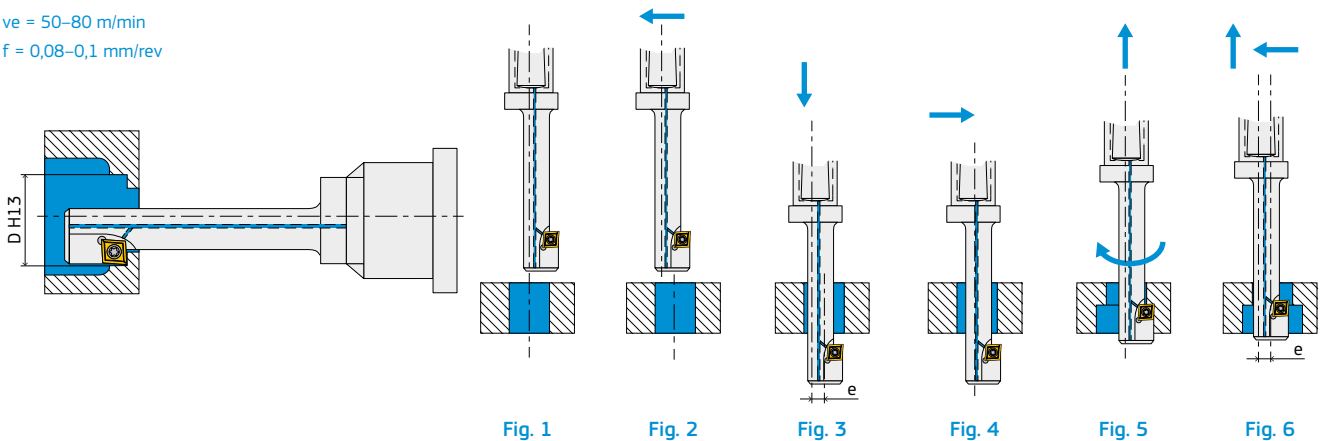

Without coolant Trockenbearbeitung

With coolant Nassbearbeitung

AB31-..., AB32-...

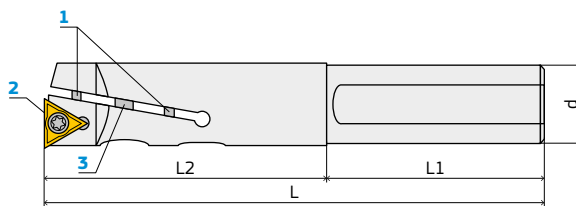

Ordering Code Bestellbezeichnung	Dimensions [mm] Abmessungen [mm]						Weight [kg] Gewicht [kg]	Spare Parts Ersatzteile			
	L	L1	L2	d	Dmin	Dmax		Adjust screw Zugschraube 1	Insert screw Wpl. Schraube 2	Clampscrew Drukschraube 3	Insert Wendeplatte
AB31-020.01.90.11.2-0.1	120	60	60	20	20	25	0,270	RE 3	VT25	BL 3	TCMT 1102 ...
AB31-025.01.90.16.2-0.1	140	70	70	25	25	30	0,480	RE 4	VT40	BL 4	TCMT 16T3 ...
AB31-030.01.90.16.2-0.1	160	70	90	25	30	35	0,620	RE 5	VT40	BL 5	TCMT 16T3 ...
AB31-035.01.90.16.2-0.1	170	70	100	32	35	40	1,050	RE 6	VT40	BL 6	TCMT 16T3 ...
AB31-040.01.90.16.2-0.1	190	70	120	32	40	45	1,400	RE 7	VT40	BL 7	TCMT 16T3 ...
AB31-045.01.90.16.2-0.1	220	70	150	32	45	50	2,040	RE 8	VT40	BL 10	TCMT 16T3 ...
AB32-010.01.90.06.2-0.1	100	70	30	10	10	12	0,070	RE 1	VT25	BL 0	CCMT 0602 ...
AB32-012.01.90.06.2-0.1	105	70	30	12	12	15	0,100	RE 1	VT25	BL 1	CCMT 0602 ...
AB32-015.01.90.06.2-0.1	110	60	50	16	15	20	0,170	RE 2	VT25	BL 2	CCMT 0602 ...
AB32-020.01.90.06.2-0.1	120	60	60	20	20	25	0,270	RE 3	VT25	BL 3	CCMT 0602 ...
AB32-025.01.90.09.2-0.1	140	70	70	25	25	30	0,480	RE 4	VT35	BL 4	CCMT 09T3 ...
AB32-030.01.90.09.2-0.1	160	70	90	25	30	35	0,620	RE 5	VT35	BL 5	CCMT 09T3 ...
AB32-035.01.90.09.2-0.1	170	70	100	32	35	40	1,050	RE 6	VT35	BL 6	CCMT09T3 ...
AB32-040.01.90.09.2-0.1	190	70	120	32	40	45	1,400	RE 7	VT35	BL 7	CCMT 09T3 ...
AB32-045.01.90.09.2-0.1	220	70	150	32	45	50	2,040	RE 8	VT35	BL 10	CCMT 09T3 ...
Long models Lange Ausführung											
AB31-020L.01.90.11.2-0.1	150	70	80	20	20	25	0,370	RE 3	VT25	BL 3	TCMT 1102 ...
AB31-025L.01.90.16.2-0.1	170	70	100	25	25	30	0,580	RE 4	VT40	BL 4	TCMT 16T3 ...
AB31-030L.01.90.16.2-0.1	190	70	120	25	30	35	0,720	RE 5	VT40	BL 5	TCMT 16T3 ...
AB31-035L.01.90.16.2-0.1	220	70	150	32	35	40	1,150	RE 6	VT40	BL 6	TCMT 16T3 ...





Without coolant Trockenbearbeitung



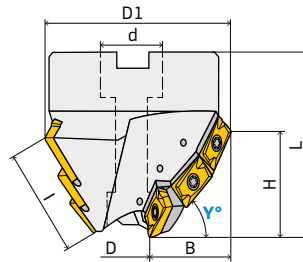

With coolant Nassbearbeitung

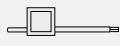
CH33-...

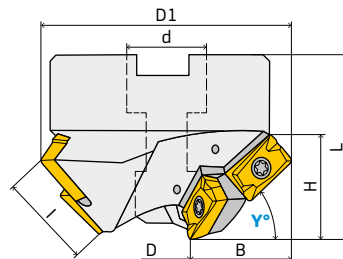
Ordering Code Bestellbezeichnung	Dimensions [mm] Abmessungen [mm]										Weight [kg] Gewicht [kg]	Spare Parts Ersatzteile		
	D	D1	d	L	B	I	Y°	H	Z	K				
CH33-056.09.45.10.2-1	17	56	22	50	17,8	27,5	45°	19	9	3	0,470	APKT 1003 ...	VT25	BT08
CH33-045.09.60.10.2-1	17	45	16	50	13	27,5	60°	24	9	3	0,280			
CH33-065.09.30.10.2-1	17	65	22	50	24	27,5	30°	13	9	3	0,600			
CH33-070.09.15.10.2-1	17	70	22	50	27	27,5	15°	7	9	3	0,770			
CH33-033.09.75.10.2-1	19	33	16	60	7	27,5	75°	27	9	3	0,270			
CH33-060.09.40.10.2-1	17	60	22	50	19	27,5	40°	17	9	3	0,520			
CH33-069.09.20.10.2-1	17	69	22	50	26	27,5	20°	9	9	3	0,700			

CH34-...

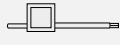
Ordering Code Bestellbezeichnung	Dimensions [mm] Abmessungen [mm]										Weight [kg] Gewicht [kg]	Spare Parts Ersatzteile		
	D	D1	d	L	B	I	Y°	H	Z	K				
CH34-0778.06.45.16.2-1	35	77,8	27	50	21,4	30	45°	21,5	6	3	0,780	APKT 1604 ...	VT40	BT15
CH34-065.06.60.16.2-1	35	65	27	50	15,1	30	60°	26,5	6	3	0,580			
CH34-088.06.30.16.2-1	35	88	27	50	26,5	30	30°	15,0	6	3	1,000			
CH34-094.06.15.16.2-1	35	94	27	50	29,5	30	15°	8,0	6	3	1,190			
CH34-0507.06.75.16.2-1	35	50,7	22	60	8	30	75°	29,5	6	3	0,460			
CH34-084.06.40.16.2-1	35	84	27	50	24,5	30	40°	19	6	3	0,860			
CH34-091.06.20.16.2-1	35	91	27	50	28,5	30	20°	10	6	3	1,130			
CH34-073.06.50.16.2-1	35	73	27	50	18	30	50°	23	6	3	0,820			



Without coolant Trockenbearbeitung



With coolant Nassbearbeitung

Solid Carbide Tools

Vollhartmetall Werkzeuge



<p>71</p> <p>Solid Carbide Milling Cutters Vollhartmetall Fräswerkzeuge</p> <p>Symbol Navigator Symbol-Navigator 71</p> <p>Application Anwendung 72</p> <p>Slot Drills (2-fluted), Centre Cutting Schafffräser (2-schneiden), mit Zentrumschnitt 73</p> <p>KTU 02N...</p> <p>Ball Nose Slot Drills (2-fluted), Centre Cutting Vollhartmetall Radiusfräser (2-schneiden), mit Zentrumschnitt 74</p> <p>KTU 02B...</p> <p>Slot Drills (3-fluted), Centre Cutting Schafffräser (3-schneiden), mit Zentrumschnitt 75</p> <p>KTU 03N...</p> <p>End Mills (4-fluted), Centre Cutting Vollhartmetall-Schafffräser (4-schneiden), mit Zentrumschnitt 76</p> <p>KTU 04N...</p> <p>High-performance End Mills, Centre Cutting Hohe Produktivität VHM-Schafffräser, mit Zentrumschnitt 77</p> <p>KTU 04N...</p> <p>Roughing End Mills (Fine Teeth), Centre Cutting Vollhartmetall-Schruppfräser (Feine Zähne), mit Zentrumschnitt 78</p> <p>KTU 04R..., KTU 05R...</p> <p>High-performance Finishing End Mills, Centre Cutting Hohe Produktivität VHM-Schafffräser, mit Zentrumschnitt 79</p> <p>KTU 06N..., KTU 08N...</p> <p>End Mills Alu, Centre Cutting Alu-Schafffräser, mit Zentrumschnitt 80</p> <p>KTA 02W...; KTA 03W...; KTA 03W...</p> <p>End Mills, Centre Cutting Vollhartmetall-Schafffräser, mit Zentrumschnitt 83</p> <p>KTH 04N...</p> <p>Hard Multi-tooth End Mills, Centre Cutting Mehrzahn-Schafffräser, mit Zentrumschnitt 84</p> <p>KTH 06N..., KTH 08N...</p>	<p>86</p> <p>Solid Carbide Drills Vollhartmetall-Bohrer</p> <p>Symbol Navigator Symbol-Navigator 86</p> <p>KD3D-... 87</p> <p>KD3DC-... 88</p> <p>KD5DC-... 91</p> <p>Cutting Values Schneidwerte 94</p>	<p>96</p> <p>Technical Hints Technische Hinweise</p> <p>Ramping Rampe eintauchen 96</p> <p>Formulas Formeln 96</p> <p>Calculation of Approach Angle φ_s Berechnung des Eingriffswinkels φ_s 97</p>
<p>98</p> <p>Attachment Anhang</p> <p>Dimensions, units and application formulas Maße, Einheiten, Anwendungsformeln 98</p> <p>Solutions of Problems in Milling Lösungen von Problemen beim Fräsen 99</p> <p>Material Comparison Chart Werkstoffe – Vergleichstabelle 100</p>		

Symbol Navigator

Symbol-Navigator

Application Anwendungen



Slotting
Nuten



Roughing
Schruppen



Ramping
Rampen



Helix
Wendel



Drilling
Bohren



Finishing
Schlichten



Copying
Kopieren

Shank form Schaftform



To DIN 6535
Nach DIN 6535

Cutting edge form Schneidenform



45°
Corner chamfer
Eckenfase



R±0,5
Radius with tolerance
Radius mit Toleranz

Standard Norm



To DIN
Nach DIN

Rake angle Spanwinkel

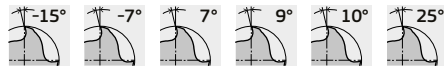

Rake angle of circumference cutting edges
Spanwinkel der Umfangsschneiden

Type Typ



Application range similar to DIN 1836
Einsatzbereich ähnlich zu DIN 1836

Feed Zustellung



For lateral feed
Für seitliche
Einstellung



For lateral feed and
oblique plunging
Für seitliche
Zustellung und zum
Schrägeintauchen



For lateral feed, oblique
plunging and drilling
Für seitliche Zustellungen,
zum Schrägeintauchen
und Bohren

Length Länge



Long (DIN)
Lang (DIN)

Extra length
Extra lang

Coating Beschichtung



With coating
Mit Beschichtung



Without coating
Ohne Beschichtung

Number of cutting edges Schneidenzahl



Number of major cutting edges
Anzahl der Hauptschneiden

Helix angle Spiralwinkel



Size of helix angle / number of different helix angles
Größe des Spiralwinkels / Anzahl unterschiedlicher Spiralwinkel

Application

Anwendung

Name Name		Application Anwendung
KTU	Konrad Tools Universal	For steel, stainless steel, cast materials, aluminium, titanium alloys, hardened steel up to 54 HRC Für Stahl, rostfreie Stähle, Gusswerkstoffen, Aluminium, Titanlegierungen, Gehärteter Stahl bis 54 HRC
KTA	Konrad Tools Aluminium	For aluminium Für Aluminium
KTH	Konrad Tools Hardened	For hardened steel up to 63 HRC, cast materials, steel Für Gehärteter Stahl bis 63 HRC, Gusswerkstoffen, Stahl

Slot Drills (2-fluted), Centre Cutting

Schaftfräser (2-schneiden), mit Zentrumschnitt

KTU 02N...

Universal solid carbide milling cutter

Universele vollhartmetall schaftfräser

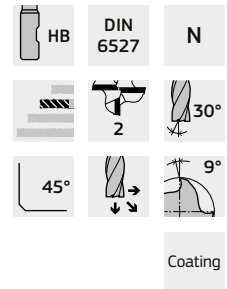
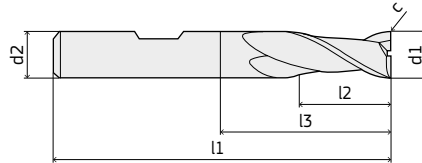

Ordering Code Bestellbezeichnung	Tool material Werk. material	Dimensions [mm] Abmessungen [mm]					c [mm × 45°]	Z
		d1 h10	d2 h6	l1	l2	l3		
KTU 02N060-020	Solid carbide with coating Vollhartmetall mit beschich- tung	2,000	6,000	57,00	6,00	9,40	0,03	2
KTU 02N070-030		3,000	6,000	57,00	7,00	11,90	0,05	2
KTU 02N080-040		4,000	6,000	57,00	8,00	13,40	0,05	2
KTU 02N100-050		5,000	6,000	57,00	10,00	16,90	0,05	2
KTU 02N100-060		6,000	6,000	57,00	10,00	21,00	0,05	2
KTU 02N130-070		7,000	8,000	63,00	13,00	22,40	0,10	2
KTU 02N160-080		8,000	8,000	63,00	16,00	27,00	0,10	2
KTU 02N160-090		9,000	10,000	72,00	16,00	27,40	0,10	2
KTU 02N190-100		10,000	10,000	72,00	19,00	32,00	0,10	2
KTU 02N220-120		12,000	12,000	83,00	22,00	38,00	0,10	2

Cutting values: Slotting* and roughing

Schnittwerte: Vollnutfräsen* und Schruppen

Material group Werkstoffgruppe	Material Werkstoff	Hardness Härte	Feed depth Schmittiefe	Feed width Schmittbreite	Cutting speed Schneidgesch- windigkeit	f_z [mm/z] with nom. \emptyset f_z [mm/z] bei-Nenn \emptyset							
			a_p	a_e^{**}		v_c	2	4	6	8	10	12	16
P	Steel	$\leq 850 \text{ N/mm}^2$	$0,5 \times d$	$1 \times d$	125	0,013	0,018	0,025	0,032	0,042	0,049	0,063	0,07
	Stahl	$850\text{--}1400 \text{ N/mm}^2$	$0,5 \times d$	$1 \times d$	95	0,01	0,015	0,02	0,024	0,033	0,039	0,048	0,057
M	Stainless steel	$\leq 750 \text{ N/mm}^2$	$0,5 \times d$	$1 \times d$	85	0,01	0,015	0,02	0,024	0,033	0,039	0,048	0,057
	Rostfreier stahl	$\geq 750 \text{ N/mm}^2$	$0,5 \times d$	$1 \times d$	50	0,007	0,01	0,015	0,018	0,027	0,03	0,039	0,048
K	Cast mat. Guswekrstoffen	$\geq 240 \text{ HB } 30$	$0,5 \times d$	$1 \times d$	100	0,01	0,015	0,02	0,024	0,033	0,039	0,048	0,057
N	Aluminium Aluminium	$\leq 7\% \text{ Si}$	$1 \times d$	$1 \times d$	160	0,013	0,018	0,025	0,032	0,042	0,049	0,063	0,07

* Peripheral cooling is recommended for optimal chip evacuation and tool life.

Für optimale Spanabfuhr und Standweg wird Peripheriekühlung empfohlen.

 ** For slotting with $a_e = 0,02 \times d$ the cutting speed v_c can be increased by 50%.

 Beim Schlichten mit $a_e = 0,02 \times d$ kann die Schnittgeschwindigkeit v_c um 50% erhöht werden.

 All recommendations are valid for coated tools. For bright milling cutters please v_c -40% and f_z -25%!

 Alle Angaben beziehen sich auf beschichtete Werkzeuge. Bei blanken Werkzeugen bitte v_c -40% und f_z -25%!

Ball Nose Slot Drills (2-fluted), Centre Cutting

Vollhartmetall Radiusfäser (2-schneiden), mit Zentrumschnitt

KTU 02B...
Universal solid carbide milling cutter

Universele vollhartmetall schaftfräser

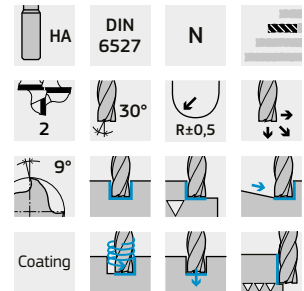
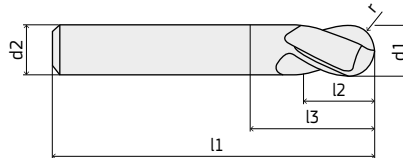

Ordering Code Bestellbezeichnung	Tool material Werk. material	Dimensions [mm] Abmessungen [mm]						Z
		d1 h10	d2 h6	l1	l2	l3	r	
KTU 02B020-010	Solid carbide with coating Vollhartmetall mit beschich- tung	1,000	3,000	38,00	2,00	3,90	0,50	2
KTU 02B030-015		1,500	3,000	38,00	3,00	6,40	0,75	2
KTU 02B060-020		2,000	6,000	57,00	6,00	9,40	1,00	2
KTU 02B070-030		3,000	6,000	57,00	7,00	11,90	1,50	2
KTU 02B080-040		4,000	6,000	57,00	8,00	13,40	2,00	2
KTU 02B100-050		5,000	6,000	57,00	10,00	16,90	2,50	2
KTU 02B100-060		6,000	6,000	57,00	10,00	21,00	3,00	2
KTU 02B160-080		8,000	8,000	63,00	16,00	27,00	4,00	2
KTU 02B190-100		10,000	10,000	72,00	19,00	32,00	5,00	2
KTU 02B220-120		12,000	12,000	83,00	22,00	38,00	6,00	2
KTU 02B220-140		14,000	14,000	83,00	22,00	38,00	7,00	2
KTU 02B260-160		16,000	16,000	92,00	26,00	44,00	8,00	2
KTU 02B260-180		18,000	18,000	92,00	26,00	44,00	9,00	2
KTU 02B320-200		20,000	20,000	104,00	32,00	54,00	10,00	2

Cutting values: Slotting* and roughing

Schnittwerte: Vollnutfräsen* und Schruppen

Material group Werkstoffgruppe	Material Werkstoff	Hardness Härte	Feed depth Schmittiefe	Feed width Schmittbreite	Cutting speed Schneidgesch- windigkeit	f_z [mm/z] with nom. \emptyset f_z [mm/z] bei-Nenn \emptyset							
						a_p	a_e^{**}	v_c	2	4	6	8	10
P	Steel	$\leq 850 \text{ N/mm}^2$	$0,5 \times d$	$0,4 \times d$	175	0,03	0,04	0,045	0,05	0,07	0,1	0,12	0,15
	Stahl	$850-1400 \text{ N/mm}^2$	$0,5 \times d$	$0,3 \times d$	140	0,03	0,04	0,045	0,05	0,07	0,1	0,12	0,15
M	Stainless steel	$\leq 750 \text{ N/mm}^2$	$1 \times d$	$0,1 \times d$	126	0,03	0,04	0,045	0,05	0,07	0,1	0,12	0,15
	Rostfreier stahl	$\geq 750 \text{ N/mm}^2$	$1 \times d$	$0,1 \times d$	56	0,02	0,03	0,035	0,04	0,05	0,07	0,08	0,1
N	Aluminium Aluminium	$\leq 7\% \text{ Si}$	$1 \times d$	$0,3 \times d$	196	0,03	0,04	0,045	0,05	0,07	0,1	0,12	0,15
S	Ti sp. alloys Titanlegierungen	$\leq 1300 \text{ N/mm}^2$	$1 \times d$	$0,1 \times d$	56	0,02	0,03	0,035	0,04	0,05	0,07	0,08	0,1
H	Hardened steel Gehärteter Stahl	up to 54 HRC	$0,05 \times d$	$0,05 \times d$	70	0,02	0,03	0,035	0,04	0,05	0,07	0,08	0,1

* Peripheral cooling is recommended for optimal chip evacuation and tool life, for hard machining air cooling is recommended.

Für optimale Spanabfuhr und Standweg wird Peripheriekühlung und bei Hartbearbeitung Luftkühlung empfohlen.

 ** For HSC-finishing with $a_e = 0,02 \times d$ the cutting speed v_c can be increased by 50%.

 Beim HSC-Schlichten mit $a_e = 0,02 \times d$ kann die Schnittgeschwindigkeit v_c um 50% erhöht werden.

Slot Drills (3-fluted), Centre Cutting

Schaftfräser (3-schneiden), mit Zentrumschnitt

KTU 03N...

Universal solid carbide milling cutter

Universele vollhartmetall schaftfräser

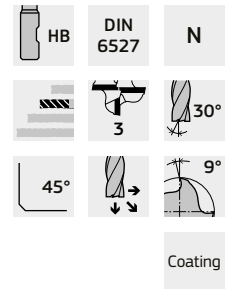
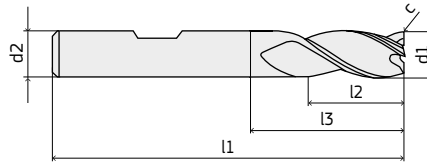

Ordering Code Bestellbezeichnung	Tool material Werk. material	Dimensions [mm] Abmessungen [mm]					c [mm × 45°]	Z
		d1 h10	d2 h6	l1	l2	l3		
KTU 03N060-020	Solid carbide with coating Vollhartmetall mit beschich- tung	2,000	6,000	57,00	6,00	10,40	0,03	3
KTU 03N070-025		2,500	6,000	57,00	7,00	11,40	0,05	3
KTU 03N070-030		3,000	6,000	57,00	7,00	11,40	0,05	3
KTU 03N070-035		3,500	6,000	57,00	7,00	11,40	0,05	3
KTU 03N080-040		4,000	6,000	57,00	8,00	13,90	0,05	3
KTU 03N080-045		4,500	6,000	57,00	8,00	13,90	0,05	3
KTU 03N100-050		5,000	6,000	57,00	10,00	16,90	0,05	3
KTU 03N100-060		6,000	6,000	57,00	10,00	21,00	0,05	3
KTU 03N130-070		7,000	8,000	63,00	13,00	21,90	0,10	3
KTU 03N160-080		8,000	8,000	63,00	16,00	27,00	0,10	3
KTU 03N160-090		9,000	10,000	72,00	16,00	27,40	0,10	3
KTU 03N190-100		10,000	10,000	72,00	19,00	32,00	0,10	3
KTU 03N220-120		12,000	12,000	83,00	22,00	38,00	0,10	3
KTU 03N220-140		14,000	14,000	83,00	22,00	38,00	0,15	3
KTU 03N260-160		16,000	16,000	92,00	26,00	44,00	0,15	3
KTU 03N260-180		18,000	18,000	92,00	26,00	44,00	0,15	3
KTU 03N320-200		20,000	20,000	104,00	32,00	54,00	0,15	3

Cutting values: Slotting* and roughing

Schnittwerte: Vollnutfräsen* und Schruppen

Material group Werkstoffgruppe	Material Werkstoff	Hardness Härte	Feed depth Schmitttiefe	Feed width Schmittbreite	Cutting speed Schneidgesch- windigkeit	f _z [mm/z] with nom. Ø f _z [mm/z] bei-Nenn Ø							
			a _p	a _e **	v _c	2	4	6	8	10	12	16	20
P	Steel	≤ 850 N/mm ²	0,5×d	1×d	125	0,013	0,018	0,025	0,032	0,042	0,049	0,063	0,07
	Stahl	850–1400 N/mm ²	0,5×d	1×d	95	0,01	0,015	0,02	0,024	0,033	0,039	0,048	0,057
M	Stainless steel	≤ 750 N/mm ²	0,5×d	1×d	85	0,01	0,015	0,02	0,024	0,033	0,039	0,048	0,057
	Rostfreier stahl	≥ 750 N/mm ²	0,5×d	1×d	50	0,007	0,01	0,015	0,018	0,027	0,03	0,039	0,048
K	Cast mat. Guswekrstoffen	≥ 240 HB 30	0,5×d	1×d	100	0,01	0,015	0,02	0,024	0,033	0,039	0,048	0,057
N	Aluminium Aluminium	≤ 7% Si	1×d	1×d	160	0,013	0,018	0,025	0,032	0,042	0,049	0,063	0,07

* Peripheral cooling is recommended for optimal chip evacuation and tool life.

Für optimale Spanabfuhr und Standweg wird Peripheriekühlung empfohlen.

 ** For slotting with a_e = 0,02×d the cutting speed v_c can be increased by 50%.

 Beim Schlichten mit a_e = 0,02×d kann die Schnittgeschwindigkeit v_c um 50% erhöht werden.

 All recommendations are valid for coated tools. For bright milling cutters please v_c -40% and f_z -25%!

 Alle Angaben beziehen sich auf beschichtete Werkzeuge. Bei blanken Werkzeugen bitte v_c -40% und f_z -25%!

End Mills (4-fluted), Centre Cutting

Vollhartmetall-Schaftfräser (4-schneiden), mit Zentrumschnitt

KTU 04N...

Universal solid carbide milling cutter

Universele vollhartmetall schaftfräser

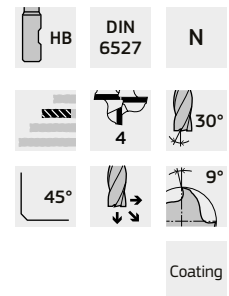
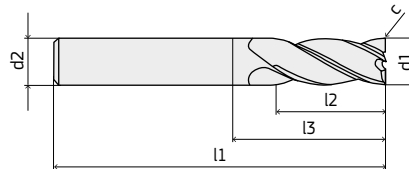

Ordering Code Bestellbezeichnung	Tool material Werk. material	Dimensions [mm] Abmessungen [mm]					c [mm × 45°]	Z
		d1 h10	d2 h6	l1	l2	l3		
KTU 04N070-020	Solid carbide with coating Vollhartmetall mit beschich- tung	2,000	6,000	57,00	7,00	11,40	0,03	4
KTU 04N080-030		3,000	6,000	57,00	8,00	12,90	0,05	4
KTU 04N110-040		4,000	6,000	57,00	11,00	16,90	0,05	4
KTU 04N130-050		5,000	6,000	57,00	13,00	19,90	0,05	4
KTU 04N130-060		6,000	6,000	57,00	13,00	21,00	0,05	4
KTU 04N160-070		7,000	8,000	63,00	16,00	23,90	0,10	4
KTU 04N190-080		8,000	8,000	63,00	19,00	27,00	0,10	4
KTU 04N190-090		9,000	10,000	72,00	19,00	28,40	0,10	4
KTU 04N220-100		10,000	10,000	72,00	22,00	32,00	0,10	4
KTU 04N260-120		12,000	12,000	83,00	26,00	38,00	0,10	4
KTU 04N260-140		14,000	14,000	83,00	26,00	38,00	0,15	4
KTU 04N320-160		16,000	16,000	92,00	32,00	44,00	0,15	4
KTU 04N320-180		18,000	18,000	92,00	32,00	44,00	0,15	4
KTU 04N380-200		20,000	20,000	104,00	38,00	54,00	0,15	4

Cutting values: Slotting* and roughing

Schnittwerte: Vollnutfräsen* und Schruppen

Material group Werkstoffgruppe	Material Werkstoff	Hardness Härte	Feed depth Schmittiefe	Feed width Schmittbreite	Cutting speed Schneidgesch- windigkeit	f_z [mm/z] with nom. \emptyset f_z [mm/z] bei-Nenn \emptyset							
			a_p	a_e^{**}		v_c	2	4	6	8	10	12	16
P	Steel	$\leq 850 \text{ N/mm}^2$	$1,5 \times d$	$0,5 \times d$	125	0,013	0,018	0,025	0,032	0,042	0,049	0,063	0,07
	Stahl	$850\text{--}1400 \text{ N/mm}^2$	$1,5 \times d$	$0,5 \times d$	95	0,01	0,015	0,02	0,024	0,033	0,039	0,048	0,057
M	Stainless steel	$\leq 750 \text{ N/mm}^2$	$1,5 \times d$	$0,5 \times d$	85	0,01	0,015	0,02	0,024	0,033	0,039	0,048	0,057
	Rostfreier stahl	$\geq 750 \text{ N/mm}^2$	$1,5 \times d$	$0,2 \times d$	50	0,007	0,01	0,015	0,018	0,027	0,03	0,039	0,048
K	Cast mat. Guswekrstoffen	$\geq 240 \text{ HB } 30$	$1,5 \times d$	$0,5 \times d$	100	0,01	0,015	0,02	0,024	0,033	0,039	0,048	0,057
N	Aluminium Aluminium	$\leq 7\% \text{ Si}$	$1,5 \times d$	$0,3 \times d$	160	0,013	0,018	0,025	0,032	0,042	0,049	0,063	0,07

* Peripheral cooling is recommended for optimal chip evacuation and tool life.

Für optimale Spanabfuhr und Standweg wird Peripheriekühlung empfohlen.

 ** For slotting with $a_e = 0,02 \times d$ the cutting speed v_c can be increased by 50%.

 Beim Schlichten mit $a_e = 0,02 \times d$ kann die Schnittgeschwindigkeit v_c um 50% erhöht werden.

 All recommendations are valid for coated tools. For bright milling cutters please v_c -40% and f_z -25%!

 Alle Angaben beziehen sich auf beschichtete Werkzeuge. Bei blanken Werkzeugen bitte v_c -40% und f_z -25%!

High-performance End Mills, Centre Cutting

Hohe Produktivität VHM-Schaftfräser, mit Zentrumschnitt

KTU 04N...

Universal solid carbide milling cutter

Universele vollhartmetall schaftfräser

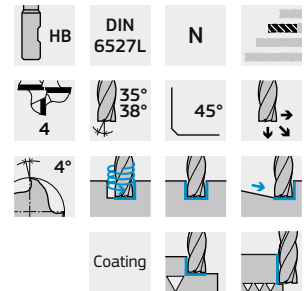
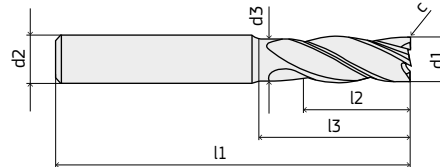

Ordering Code Bestellbezeichnung	Tool material Werk. material	Dimensions [mm] Abmessungen [mm]						c [mm × 45°]	Z
		d1 h10	d2 h6	d3	l1	l2	l3		
KTU 04N110-040	Solid carbide with coating Vollhartmetall mit beschich- tung	4,000	6,000	3,800	57,000	11,000	18,000	0,100	4
KTU 04N130-050		5,000	6,000	4,800	57,000	13,000	18,000	0,100	4
KTU 04N130-060		6,000	6,000	5,700	57,000	13,000	20,000	0,150	4
KTU 04N190-080		8,000	8,000	7,700	63,000	19,000	26,000	0,150	4
KTU 04N220-100		10,000	10,000	9,500	72,000	22,000	30,000	0,200	4
KTU 04N260-120		12,000	12,000	11,500	83,000	26,000	36,000	0,200	4
KTU 04N260-140		14,000	14,000	13,500	83,000	26,000	36,000	0,250	4
KTU 04N320-160		16,000	16,000	15,500	92,000	32,000	42,000	0,350	4
KTU 04N320-180		18,000	18,000	17,500	92,000	32,000	42,000	0,400	4
KTU 04N380-200		20,000	20,000	19,500	104,000	38,000	52,000	0,450	4
KTU 04N450-250	25,000	25,000	24,000	121,000	45,000	63,000	0,600	4	

Cutting values: HPC-roughing*
Schnittwerte: HPC-Schruppen*

Material group Werkstoffgruppe	Material Werkstoff	Hardness Härte	Feed depth Schmittiefe	Feed width Schmittbreite	Cutting speed Schneidgesch- windigkeit	f _z [mm/z] with nom. Ø f _z [mm/z] bei-Nenn Ø							
			a _p	a _e **	v _c	3	6	8	10	12	16	20	25
P	Steel	≤ 850 N/mm ²	2×d	0,3×d	200	0,02	0,04	0,055	0,07	0,085	0,1	0,12	0,17
	Stahl	850–1400 N/mm ²	2×d	0,3×d	180	0,02	0,04	0,055	0,07	0,085	0,1	0,12	0,17
K	Cast mat. Guswerkstoffen	≥ 240 HB 30	2×d	0,4×d	180	0,02	0,04	0,05	0,065	0,08	0,095	0,11	0,16

* Peripheral cooling is recommended for optimal chip evacuation and tool life.

Für optimale Spanabfuhr und Standweg wird Peripheriekühlung empfohlen.

 ** For trochoidal milling and imachining with a_e 0,1–0,2×d the cutting speed and feed rate can be increased by 50%.

 Beim Trochoidalfräsen und imachining mit a_e 0,1–0,2×d kann die Schnittgeschwindigkeit v_c und Vorschub um je 50% erhöht werden.

Roughing End Mills (Fine Teeth), Centre Cutting

Vollhartmetall-Schruppfräser (Feine Zähne), mit Zentrumschnitt

KTU 04R..., KTU 05R...

Universal solid carbide milling cutter

Universele vollhartmetall schaftfräser

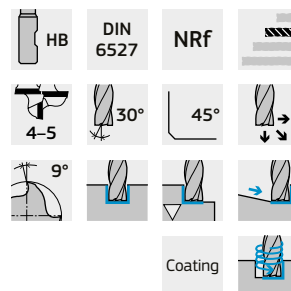
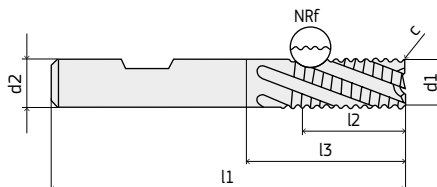

Ordering Code Bestellbezeichnung	Tool material Werk. material	Dimensions [mm] Abmessungen [mm]					c [mm × 45°]	Z
		d1 h10	d2 h6	l1	l2	l3		
KTU 04R130-060	Solid carbide with coating Vollhartmetall mit beschich- tung	6,000	6,000	57,00	13,00	21,00	0,30	4
KTU 04R190-080		8,000	8,000	63,00	19,00	27,00	0,30	4
KTU 04R220-100		10,000	10,000	72,00	22,00	32,00	0,30	4
KTU 04R260-120		12,000	12,000	83,00	26,00	38,00	0,50	4
KTU 04R260-140		14,000	14,000	83,00	26,00	38,00	0,50	4
KTU 04R320-160		16,000	16,000	92,00	32,00	44,00	0,50	4
KTU 04R320-180		18,000	18,000	92,00	32,00	44,00	0,50	4
KTU 04R380-200		20,000	20,000	104,00	38,00	54,00	0,50	4
KTU 05R450-250		25,000	25,000	121,00	45,00	65,00	0,60	5

Cutting values: Slotting* and roughing

Schnittwerte: Vollnutfräsen* und Schruppen

Material group Werkstoffgruppe	Material Werkstoff	Hardness Härte	Feed depth Schmittiefe	Feed width Schmittbreite	Cutting speed Schneidgesch- windigkeit	f_z [mm/z] with nom. \emptyset f_z [mm/z] bei-Nenn \emptyset						
						a_p	a_e^{**}	v_c	6	8	10	12
P	Steel	$\leq 850 \text{ N/mm}^2$	$2 \times d$	$0,5 \times d$	160	0,02	0,028	0,036	0,04	0,052	0,064	0,096
	Stahl	$850\text{--}1400 \text{ N/mm}^2$	$2 \times d$	$0,4 \times d$	130	0,016	0,024	0,028	0,032	0,044	0,052	0,064
M	Stainless steel	$\leq 750 \text{ N/mm}^2$	$2 \times d$	$0,25 \times d$	115	0,02	0,028	0,036	0,04	0,052	0,064	0,096
	Rostfreier stahl	$\geq 750 \text{ N/mm}^2$	$2 \times d$	$0,2 \times d$	80	0,011	0,018	0,021	0,025	0,032	0,042	0,049
K	Cast mat. Guswekrstoffen	$\geq 240 \text{ HB } 30$	$2 \times d$	$0,4 \times d$	150	0,021	0,028	0,035	0,042	0,049	0,063	0,091
N	Aluminium Aluminium	$\leq 7\% \text{ Si}$	$2 \times d$	$0,3 \times d$	250	0,024	0,032	0,04	0,048	0,056	0,072	0,104

* Peripheral cooling is recommended for optimal chip evacuation and tool life.

Für optimale Spanabfuhr und Standweg wird Peripheriekühlung empfohlen.

 ** For slotting with $a_e = 0,02 \times d$ the cutting speed v_c can be increased by 50%.

 Beim Schlichten mit $a_e = 0,02 \times d$ kann die Schnittgeschwindigkeit v_c um 50% erhöht werden.

 All recommendations are valid for coated tools. For bright milling cutters please v_c -40% and f_z -25%!

 Alle Angaben beziehen sich auf beschichtete Werkzeuge. Bei blanken Werkzeugen bitte v_c -40% und f_z -25%!

High-performance Finishing End Mills, Centre Cutting

Hohe Produktivität VHM-Schaftfräser, mit Zentrumschnitt

KTU 06N..., KTU 08N...

Universal solid carbide milling cutter

Universele vollhartmetall schaftfräser

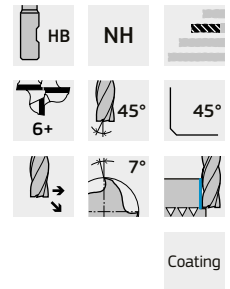
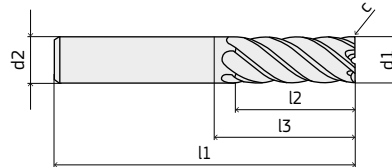

Ordering Code Bestellbezeichnung	Tool material Werk. material	Dimensions [mm] Abmessungen [mm]					c [mm × 45°]	Z
		d1 h10	d2 h6	l1	l2	l3		
KTU 06N210-060	Solid carbide with coating Vollhartmetall mit beschich- tung	6,000	6,000	57,000	13,000	21,000	0,050	6
KTU 06N270-080		8,000	8,000	63,000	19,000	27,000	0,100	6
KTU 06N320-100		10,000	10,000	72,000	22,000	32,000	0,100	6
KTU 06N380-120		12,000	12,000	83,000	26,000	38,000	0,100	6
KTU 06N440-160		16,000	16,000	92,000	32,000	44,000	0,150	6
KTU 08N540-200		20,000	20,000	104,000	38,000	54,000	0,150	8

Cutting values: Finishing* and HPC-roughing****
Schnittwerte: Schlichten * und HPC-Schruppen****

Material group Werkstoffgruppe	Material Werkstoff	Hardness Härte	Feed depth Schmittiefe a _p	Feed width Schmittbreite a _e **	Cutting speed Schneidgesch- windigkeit v _c	f _z [mm/z] with nom. Ø f _z [mm/z] bei-Nenn Ø							
						3	6	8	10	12	16	20	25
P	Steel	≤ 850 N/mm ²	2×d	0,2×d	280	0,014	0,027	0,036	0,05	0,059	0,072	0,086	0,12
	Stahl	850–1400 N/mm ²	2×d	0,15×d	180	0,012	0,024	0,032	0,04	0,048	0,056	0,072	0,104
M	Stainless steel	≤ 750 N/mm ²	2×d	0,15×d	150	0,014	0,027	0,036	0,045	0,054	0,063	0,081	0,11
	Rostfreier stahl	≥ 750 N/mm ²	2×d	0,1×d	100	0,014	0,027	0,036	0,045	0,054	0,063	0,081	0,11
K	Cast mat. Guswekrstoffen	≥ 240 HB 30	2×d	0,2×d	160	0,016	0,03	0,04	0,055	0,065	0,08	0,095	0,14
N	Aluminium Aluminium	≤ 7% Si	2×d	0,15×d	280	0,018	0,035	0,045	0,05	0,065	0,08	0,12	0,15

* Peripheral cooling is recommended for optimal chip evacuation and tool life.

Für optimale Spanabfuhr und Standweg wird Peripheriekühlung empfohlen.

 ** For trochoidal milling and imachining with a_e 0,1–0,2×d the cutting speed and feed rate can be increased by 50%.

 Beim Trochoidalfrasen und imachining mit a_e 0,1–0,2×d kann die Schnittgeschwindigkeit v_c und Vorschub um je 50% erhöht werden.

 *** For finishing with a_e 0,01×D the feed rate must be reduced by 25% to achieve optimal surfaces.

 Beim Schlichten mit a_e 0,01×D ist zum Erreichen optimaler Oberflächen der Vorschub um 25% zu reduzieren.

End Mills Alu, Centre Cutting

Alu-Schaftfräser, mit Zentrumschnitt

KTA 02W...

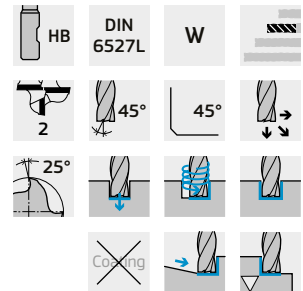
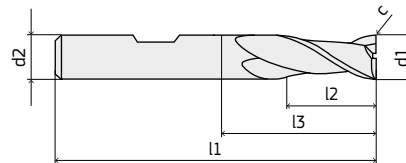
 Solid carbide milling cutter for aluminium
 Vollhartmetall-Schaftfräser für Aluminium

Ordering Code Bestellbezeichnung	Tool material Werk. material	Dimensions [mm] Abmessungen [mm]					c [mm × 45°]	Z
		d1 h10	d2 h6	l1	l2	l3		
KTA 02W070-030	Solid carbide without coating Vollhartmetall ohne beschichtung	3,000	6,000	57,000	7,000	10,900	0,030	2
KTA 02W080-040		4,000	6,000	57,000	8,000	11,900	0,030	2
KTA 02W100-050		5,000	6,000	57,000	10,000	15,400	0,030	2
KTA 02W100-060		6,000	6,000	57,000	10,000	21,000	0,030	2
KTA 02W160-080		8,000	8,000	63,000	16,000	27,000	0,050	2
KTA 02W190-100		10,000	10,000	72,000	19,000	32,000	0,050	2
KTA 02W220-120		12,000	12,000	83,000	22,000	38,000	0,100	2
KTA 02W260-160		16,000	16,000	92,000	26,000	44,000	0,100	2
KTA 02W320-200		20,000	20,000	104,000	32,000	54,000	0,100	2

Cutting values: Slotting and HPC-roughing*

Schnittwerte: Vollnutfräsen und HPC-Schruppen*

Material group Werkstoffgruppe	Material Werkstoff	Hardness Härte	Feed depth Schnitttiefe	Feed width Schnittbreite	Cutting speed Schneidgeschwindigkeit	f_z [mm/z] with nom. \emptyset f_z [mm/z] bei-Nenn \emptyset						
			a_p	a_e^{**}	v_c	3	6	8	10	12	16	20
N	Aluminium	≤ 3% Si	1×d	1×d	600	0,03	0,045	0,05	0,065	0,08	0,12	0,14
	Aluminium	≤ 7% Si	1×d	1×d	280	0,025	0,03	0,045	0,05	0,065	0,08	0,12

* Peripheral cooling is recommended for optimal chip evacuation and tool life.

Für optimale Spanabfuhr und Standweg wird Peripheriekühlung empfohlen.

 ** For trochoidal milling and imachining with a_p 2×d and a_e 0,15×d the cutting speed and feed rate can be increased by 50%.

 Beim Trochoidalfräsen und imachining mit a_p 2×d und a_e 0,15×d kann die Schnittgeschwindigkeit v_c und Vorschub um je 50% erhöht werden.

KTA 03W...

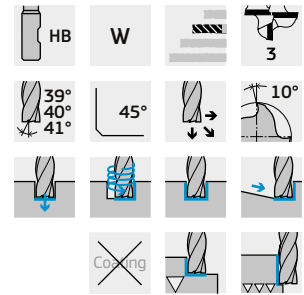
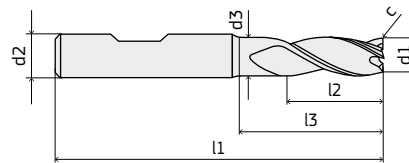
 Solid carbide milling cutter for aluminium
 Vollhartmetall-Schaftfräser für Aluminium

Ordering Code Bestellbezeichnung	Tool material Werk. material	Dimensions [mm] Abmessungen [mm]						c [mm × 45°]	Z
		d1 h10	d2 h6	d3	l1	l2	l3		
KTA 03W080-030	Solid carbide without coating Vollhartmetall ohne beschichtung	3,000	6,000	2,800	57,000	8,000	15,000	0,030	3
KTA 03W110-040		4,000	6,000	3,800	57,000	11,000	18,000	0,040	3
KTA 03W130-050		5,000	6,000	4,800	57,000	13,000	18,000	0,050	3
KTA 03W130-060		6,000	6,000	5,700	57,000	13,000	20,000	0,060	3
KTA 03W190-080		8,000	8,000	7,700	63,000	19,000	26,000	0,080	3
KTA 03W220-100		10,000	10,000	9,500	72,000	22,000	30,000	0,100	3
KTA 03W260-120		12,000	12,000	11,500	83,000	26,000	36,000	0,120	3
KTA 03W320-160		16,000	16,000	15,500	92,000	32,000	42,000	0,160	3
KTA 03W380-200		20,000	20,000	19,500	104,000	38,000	52,000	0,200	3

Cutting values: Slotting and HPC-roughing*
Schnittwerte: Vollnutfräsen und HPC-Schruppen*

Material group Werkstoffgruppe	Material Werkstoff	Hardness Härte	Feed depth Schnitttiefe	Feed width Schnittbreite	Cutting speed Schneidgeschwindigkeit	f _z [mm/z] with nom. Ø f _z [mm/z] bei-Nenn Ø							
			a _p	a _e **		v _c	3	6	8	10	12	16	20
N	Aluminium	≤ 3% Si	1×d	1×d	600	0,045	0,05	0,065	0,08	0,12	0,15	0,18	0,25
	Aluminium	≤ 7% Si	1×d	1×d	280	0,03	0,045	0,05	0,065	0,08	0,12	0,15	0,18

* Peripheral cooling is recommended for optimal chip evacuation and tool life.

Für optimale Spanabfuhr und Standweg wird Peripheriekühlung empfohlen.

 ** For trochoidal milling and machining with a_p 2×d and a_e 0,15×d the cutting speed and feed rate can be increased by 50%.

 Beim Trochoidalfräsen und imachining mit a_p 2×d und a_e 0,15×d kann die Schnittgeschwindigkeit v_c und Vorschub um je 50% erhöht werden.

KTA 03W...

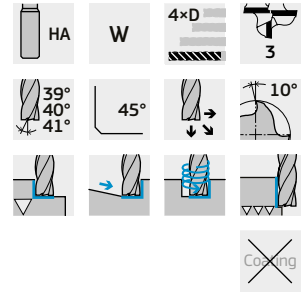
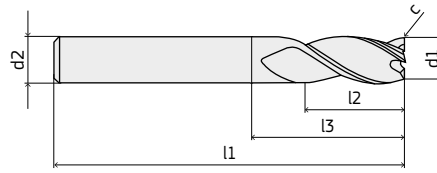
 Solid carbide milling cutter for aluminium
 Vollhartmetall-Schaftfräser für Aluminium

Ordering Code Bestellbezeichnung	Tool material Werk. material	Dimensions [mm] Abmessungen [mm]					c [mm × 45°]	Z
		d1 e8	d2 h6	l1	l2	l3		
KTA 03W240-060	Solid carbide without coating Vollhartmetall ohne beschich- tung	6,000	6,000	65,00	24,00	29,00	0,06	3
KTA 03W320-080		8,000	8,000	75,00	32,00	39,00	0,08	3
KTA 03W400-100		10,000	10,000	100,00	40,00	60,00	0,10	3
KTA 03W480-120		12,000	12,000	100,00	48,00	55,00	0,12	3
KTA 03W640-160		16,000	16,000	125,00	64,00	77,00	0,16	3
KTA 03W800-200		20,000	20,000	150,00	80,00	100,00	0,20	3

Cutting values: HPC-roughing*
Schnittwerte: HPC-Schruppen*

Material group Werkstoffgruppe	Material Werkstoff	Hardness Hardness	Feed depth Schnitttiefe	Feed width Schnittbreite	Cutting speed Schneidgesch- windigkeit	f_z [mm/z] with nom. \emptyset f_z [mm/z] with nom. \emptyset							
			a_p	a_e^{**}		v_c	3	6	8	10	12	16	20
N	Aluminium	≤ 3% Si	3×d	0,25×d	600	0,03	0,045	0,05	0,065	0,08	0,12	0,15	0,18
	Aluminium	≤ 7% Si	3×d	0,2×d	280	0,025	0,03	0,045	0,05	0,065	0,08	0,12	0,15

* Peripheral cooling is recommended for optimal chip evacuation and tool life.

Für optimale Spanabfuhr und Standweg wird Peripheriekühlung empfohlen.

 ** For trochoidal milling and machining with $a_p > 2 \times d$ and $a_e 0,15 \times d$ the cutting speed and feed rate can be increased by 50%.

 Beim Trochoidalfrasen und imachining mit $a_p > 2 \times d$ und $a_e 0,15 \times d$ kann die Schnittgeschwindigkeit v_c und Vorschub um je 50% erhöht werden.

End Mills, Centre Cutting

Vollhartmetall-Schaftfräser, mit Zentrumschnitt

KTH 04N...

Solid carbide milling cutter for hard material

Vollhartmetall-Schaftfräser für hartstoff

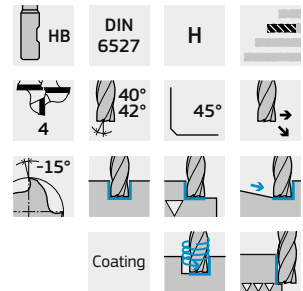
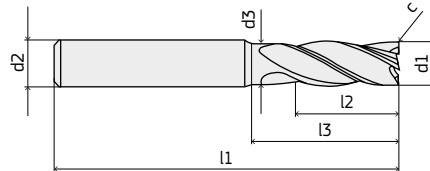

Ordering Code Bestellbezeichnung	Tool material Werk. material	Dimensions [mm] Abmessungen [mm]						c [mm × 45°]	Z
		d1 h10	d2 h6	d3	l1	l2	l3		
KTH 04N130-060	Solid carbide with coating Vollhartmetall mit beschich- tung	6,000	6,000	5,700	57,00	13,00	20,00	0,15	4
KTH 04N190-080		8,000	8,000	7,700	63,00	19,00	26,00	0,15	4
KTH 04N220-100		10,000	10,000	9,500	72,00	22,00	30,00	0,20	4
KTH 04N260-120		12,000	12,000	11,500	83,00	26,00	36,00	0,20	4
KTH 04N320-160		16,000	16,000	15,500	92,00	32,00	42,00	0,35	4
KTH 04N380-200		20,000	20,000	19,500	104,00	38,00	52,00	0,45	4

Cutting values: HPC-roughing* and hard finishing
Schnittwerte: HPC-Schruppen* und Hart-Schlichten

Material group Werkstoffgruppe	Material Werkstoff	Hardness Härte	Feed depth Schnitttiefe a_p	Feed width Schnittbreite a_e^{**}	Cutting speed Schneidgesch- windigkeit v_c	f_z [mm/z] with nom. \emptyset f_z [mm/z] bei-Nenn \emptyset						
						3	6	8	10	12	16	20
P Stahl	Steel	$\leq 850 \text{ N/mm}^2$	-	-	-	-	-	-	-	-	-	-
	Stahl	$850-1400 \text{ N/mm}^2$	$1 \times d$	-	140	0,02	0,04	0,05	0,065	0,08	0,095	0,11
K	Cast mat. Guswerkstoffen	$\geq 240 \text{ HB } 30$	$1 \times d$	$0,5 \times d$	130	0,014	0,027	0,036	0,05	0,059	0,072	0,086
H Gehärteter Stahl	Hardened steel	$\leq 54 \text{ HRC}$	$1 \times D$	$0,15 \times D$	110	0,015	0,03	0,04	0,05	0,06	0,07	0,09
	Gehärteter Stahl	$\leq 63 \text{ HRC}$	$2 \times D$	$0,03 \times D$	80	0,01	0,015	0,025	0,035	0,042	0,05	0,08

* Air cooling is recommended for optimal chip evacuation and tool life.

Für optimale Spanabfuhr und Standweg ist Lüftkühlung empfohlen.

** For slotting (up to 54 HRC) the cutting speed and feed rate should be reduced by 30%.

Beim Nuten (bis 54 HRC) sind die Schnittgeschwindigkeiten und Vorschübe um 30% zu reduzieren.

Hard Multi-tooth End Mills, Centre Cutting

Mehrzahn-Schaftfräser, mit Zentrumschnitt

KTH 06N..., KTH 08N...

Solid carbide milling cutter for hard material

Vollhartmetall-Schaftfräser für hartstoff

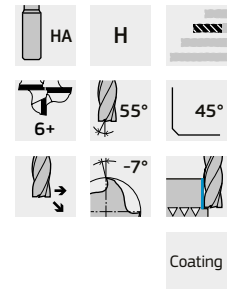
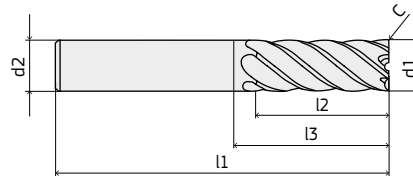

Ordering Code Bestellbezeichnung	Tool material Werk. material	Dimensions [mm] Abmessungen [mm]					c [mm × 45°]	Z
		d1 h10	d2 h6	l1	l2	l3		
KTH 06N130-060	Solid carbide with coating Vollhartmetall mit beschich- tung	6,000	6,000	57,00	13,00	21,00	0,05	6
KTH 06N190-080		8,000	8,000	63,00	19,00	27,00	0,10	6
KTH 06N220-100		10,000	10,000	72,00	22,00	32,00	0,10	6
KTH 06N260-120		12,000	12,000	83,00	26,00	38,00	0,10	6
KTH 06N260-140		14,000	14,000	83,00	26,00	38,00	0,15	6
KTH 06N320-160		16,000	16,000	92,00	32,00	44,00	0,15	6
KTH 08N320-180		18,000	18,000	92,00	32,00	44,00	0,15	8
KTH 08N380-200		20,000	20,000	104,00	38,00	54,00	0,15	8

Cutting values: Finishing* and HPC-roughing****
Schnittwerte: Schlichten* und HPC-Schruppen****

Material group Werkstoffgruppe	Material Werkstoff	Hardness Härte	Feed depth Schmittiefe	Feed width Schmittbreite	Cutting speed Schneidgesch- windigkeit	f_z [mm/z] with nom. \emptyset f_z [mm/z] bei-Nenn \emptyset							
			a_p	a_e^{**}	v_c	3	6	8	10	12	16	20	
P	Steel	$\leq 850 \text{ N/mm}^2$	-	-	-	-	-	-	-	-	-	-	-
	Stahl	$850\text{--}1400 \text{ N/mm}^2$	$2 \times d$	$0,05 \times d$	180	0,012	0,024	0,032	0,04	0,048	0,056	0,072	0,104
K	Cast mat. Guswerkstoffen	$\geq 240 \text{ HB } 30$	$2 \times d$	$0,05 \times d$	160	0,016	0,03	0,04	0,055	0,065	0,08	0,095	0,14
H	Hardened steel	$\leq 54 \text{ HRC}$	$1,5 \times d$	$0,05 \times d$	120	0,012	0,024	0,032	0,04	0,048	0,056	0,072	0,104
	Gehärteter Stahl	$\leq 63 \text{ HRC}$	$1,5 \times d$	$0,02 \times d$	90	0,01	0,015	0,025	0,035	0,042	0,05	0,08	0,09

* Peripheral cooling is recommended for optimal chip evacuation and tool life, for hard machining air cooling is recommended.

Für optimale Spanabfuhr und Standweg wird Peripheriekuhlung und bei Hartbearbeitung Luftkuhlung empfohlen.

 ** For trochoidal milling and imachining with a_e $0,1\text{--}0,2 \times d$ the cutting speed and feed rate can be increased by 50%.

 Beim Trochoidalfrasen und imachining mit a_e $0,1\text{--}0,2 \times d$ kann die Schnittgeschwindigkeit v_c und Vorschub um je 50% erhöht werden.

 *** For finishing with a_e $0,01 \times D$ the feed rate must be reduced by 25% to achieve optimal surfaces.

 Beim Schlichten mit a_e $0,01 \times D$ ist zum Erreichen optimaler Oberflächen der Vorschub um 25% zu reduzieren.

Symbol Navigator

Symbol-Navigator

Shank form Schaftform



To DIN 6535
Nach DIN 6535



Cylindrical
Zylindrisch

Standard Norm



To DIN
Nach DIN

Type Typ



Application range similar to DIN 1836
Einsatzbereich ähnlich zu DIN 1836

Cutting edge form Schneidenform

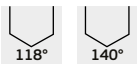

Chamfer end mill angles
Winkel der Fasfräser

Cutting depth Bearbeitungstiefe

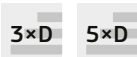

Tolerance on Ø Toleranz auf Ø

m7 h7

Internal coolant Innenkühlung



With internal coolant
Mit Innenkühlung



Without internal coolant
Ohne Innenkühlung

Coating Beschichtung



With coating
Mit Beschichtung



Without coating
Ohne Beschichtung

Cutting direction Schneidrichtung



Right-hand cutting
Rechts schneide



Left-hand cutting
Links schneide

KD3D-...

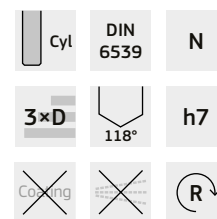
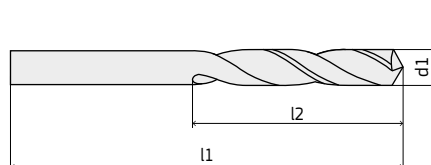

Ordering Code Bestellbezeichnung	Tool material Werk. material	Dimensions [mm] Abmessungen [mm]		
		d1	l1	l2
KD3D-020	Solid carbide without coating Vollhartmetall ohne beschich- tung	2,000	38,000	12,000
KD3D-021		2,100	38,000	12,000
KD3D-022		2,200	40,000	13,000
KD3D-023		2,300	40,000	13,000
KD3D-024		2,400	43,000	14,000
KD3D-025		2,500	43,000	14,000
KD3D-026		2,600	43,000	14,000
KD3D-027		2,700	46,000	16,000
KD3D-028		2,800	46,000	16,000
KD3D-029		2,900	46,000	16,000
KD3D-030		3,000	46,000	16,000

Material group Werkstoffgruppe	Application Anwendungen
P	○
M	○
K	○
N	●
S	○
H	

Web thinning $\geq \varnothing 2,100$; facet point grinding; main cutting edge form straight
Ausspitzung $\geq \varnothing 2,100$; Flächenanschliff; Hauptschneidenform gerade

Structural and case hardened steels; free-cutting steels, heat-treatable steels; gray cast iron; bronze, brass;
aluminium and Al-alloys; Magnesium and magnesium alloys; plastics
Bau- und Einsatzstähle; Automatenstähle, Vergütungsstähle; Grauguss; Bronze, Messing;
Aluminium und Al-Legierungen; Magnesium und Mg-Legierungen; Kunststoffe und faserverstärkte Kunststoffe

- Main application Hauptanwendung
- Secondary application Sekundäre Anwendung

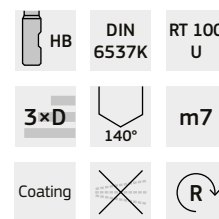
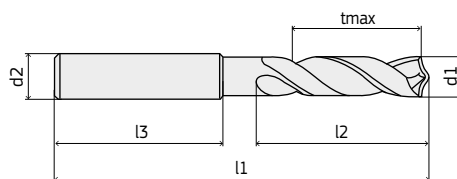
KD3DC...

Ordering Code Bestellbezeichnung	Tool material Werk. material	Dimensions [mm] Abmessungen [mm]					
		d1	d2 h6	l1	l2	l3	tmax
KD3DC-030	Solid carbide with coating Vollhartmetall mit beschich- tung	3,000	6,00	62,00	20,00	36,00	15,5
KD3DC-031		3,100	6,00	62,00	20,00	36,00	15,35
KD3DC-032		3,200	6,00	62,00	20,00	36,00	15,2
KD3DC-033		3,300	6,00	62,00	20,00	36,00	15,05
KD3DC-034		3,400	6,00	62,00	20,00	36,00	14,9
KD3DC-035		3,500	6,00	62,00	20,00	36,00	14,75
KD3DC-036		3,600	6,00	62,00	20,00	36,00	14,6
KD3DC-037		3,700	6,00	62,00	20,00	36,00	14,45
KD3DC-038		3,800	6,00	66,00	24,00	36,00	18,3
KD3DC-039		3,900	6,00	66,00	24,00	36,00	18,15
KD3DC-040		4,000	6,00	66,00	24,00	36,00	18
KD3DC-041		4,100	6,00	66,00	24,00	36,00	17,85
KD3DC-042		4,200	6,00	66,00	24,00	36,00	17,7
KD3DC-043		4,300	6,00	66,00	24,00	36,00	17,55
KD3DC-044		4,400	6,00	66,00	24,00	36,00	17,4
KD3DC-045		4,500	6,00	66,00	24,00	36,00	17,25
KD3DC-046		4,600	6,00	66,00	24,00	36,00	17,1
KD3DC-0465		4,650	6,00	66,00	24,00	36,00	17,025
KD3DC-047		4,700	6,00	66,00	24,00	36,00	16,95
KD3DC-0476		4,760	6,00	66,00	28,00	36,00	20,86
KD3DC-048		4,800	6,00	66,00	28,00	36,00	20,8
KD3DC-049		4,900	6,00	66,00	28,00	36,00	20,65
KD3DC-050		5,000	6,00	66,00	28,00	36,00	20,5
KD3DC-051		5,100	6,00	66,00	28,00	36,00	20,35
KD3DC-052		5,200	6,00	66,00	28,00	36,00	20,2
KD3DC-053		5,300	6,00	66,00	28,00	36,00	20,05
KD3DC-054		5,400	6,00	66,00	28,00	36,00	19,9
KD3DC-055		5,500	6,00	66,00	28,00	36,00	19,75
KD3DC-0555		5,550	6,00	66,00	28,00	36,00	19,675
KD3DC-056		5,600	6,00	66,00	28,00	36,00	19,6
KD3DC-057		5,700	6,00	66,00	28,00	36,00	19,45
KD3DC-058		5,800	6,00	66,00	28,00	36,00	19,3
KD3DC-059		5,900	6,00	66,00	28,00	36,00	19,15
KD3DC-060		6,000	6,00	66,00	28,00	36,00	19
KD3DC-061		6,100	8,00	79,00	34,00	36,00	24,85
KD3DC-062		6,200	8,00	79,00	34,00	36,00	24,7
KD3DC-063		6,300	8,00	79,00	34,00	36,00	24,55
KD3DC-064		6,400	8,00	79,00	34,00	36,00	24,4
KD3DC-065		6,500	8,00	79,00	34,00	36,00	24,25
KD3DC-066		6,600	8,00	79,00	34,00	36,00	24,1
KD3DC-067		6,700	8,00	79,00	34,00	36,00	23,95
KD3DC-068		6,800	8,00	79,00	34,00	36,00	23,8
KD3DC-069		6,900	8,00	79,00	34,00	36,00	23,65
KD3DC-070		7,000	8,00	79,00	34,00	36,00	23,5
KD3DC-071		7,100	8,00	79,00	41,00	36,00	30,35
KD3DC-072		7,200	8,00	79,00	41,00	36,00	30,2
KD3DC-073	7,300	8,00	79,00	41,00	36,00	30,05	
KD3DC-074	7,400	8,00	79,00	41,00	36,00	29,9	
KD3DC-075	7,500	8,00	79,00	41,00	36,00	29,75	
KD3DC-076	7,600	8,00	79,00	41,00	36,00	29,6	

Ordering Code Bestellbezeichnung	Tool material Werk. material	Dimensions [mm] Abmessungen [mm]					
		d1	d2 h6	l1	l2	l3	tmax
KD3DC-077	Solid carbide with coating Vollhartmetall mit beschich- tung	7,700	8,00	79,00	41,00	36,00	29,45
KD3DC-078		7,800	8,00	79,00	41,00	36,00	29,3
KD3DC-079		7,900	8,00	79,00	41,00	36,00	29,15
KD3DC-080		8,000	8,00	79,00	41,00	36,00	29
KD3DC-081		8,100	10,00	89,00	47,00	40,00	34,85
KD3DC-082		8,200	10,00	89,00	47,00	40,00	34,7
KD3DC-083		8,300	10,00	89,00	47,00	40,00	34,55
KD3DC-084		8,400	10,00	89,00	47,00	40,00	34,4
KD3DC-085		8,500	10,00	89,00	47,00	40,00	34,25
KD3DC-086		8,600	10,00	89,00	47,00	40,00	34,1
KD3DC-087		8,700	10,00	89,00	47,00	40,00	33,95
KD3DC-088		8,800	10,00	89,00	47,00	40,00	33,8
KD3DC-089		8,900	10,00	89,00	47,00	40,00	33,65
KD3DC-090		9,000	10,00	89,00	47,00	40,00	33,5
KD3DC-091		9,100	10,00	89,00	47,00	40,00	33,35
KD3DC-092		9,200	10,00	89,00	47,00	40,00	33,2
KD3DC-093		9,300	10,00	89,00	47,00	40,00	33,05
KD3DC-094		9,400	10,00	89,00	47,00	40,00	32,9
KD3DC-095		9,500	10,00	89,00	47,00	40,00	32,75
KD3DC-096		9,600	10,00	89,00	47,00	40,00	32,6
KD3DC-097		9,700	10,00	89,00	47,00	40,00	32,45
KD3DC-098		9,800	10,00	89,00	47,00	40,00	32,3
KD3DC-099		9,900	10,00	89,00	47,00	40,00	32,15
KD3DC-100		10,000	10,00	89,00	47,00	40,00	32
KD3DC-101		10,100	12,00	102,00	55,00	45,00	39,85
KD3DC-102		10,200	12,00	102,00	55,00	45,00	39,7
KD3DC-103		10,300	12,00	102,00	55,00	45,00	39,55
KD3DC-104		10,400	12,00	102,00	55,00	45,00	39,4
KD3DC-105		10,500	12,00	102,00	55,00	45,00	39,25
KD3DC-106		10,600	12,00	102,00	55,00	45,00	39,1
KD3DC-107		10,700	12,00	102,00	55,00	45,00	38,95
KD3DC-108		10,800	12,00	102,00	55,00	45,00	38,8
KD3DC-109		10,900	12,00	102,00	55,00	45,00	38,65
KD3DC-110		11,000	12,00	102,00	55,00	45,00	38,5
KD3DC-111		11,100	12,00	102,00	55,00	45,00	38,35
KD3DC-112		11,200	12,00	102,00	55,00	45,00	38,2
KD3DC-113		11,300	12,00	102,00	55,00	45,00	38,05
KD3DC-114		11,400	12,00	102,00	55,00	45,00	37,9
KD3DC-115		11,500	12,00	102,00	55,00	45,00	37,75
KD3DC-116		11,600	12,00	102,00	55,00	45,00	37,6
KD3DC-117		11,700	12,00	102,00	55,00	45,00	37,45
KD3DC-118		11,800	12,00	102,00	55,00	45,00	37,3
KD3DC-119		11,900	12,00	102,00	55,00	45,00	37,15
KD3DC-120		12,000	12,00	102,00	55,00	45,00	37
KD3DC-122		12,200	14,00	107,00	60,00	45,00	41,7
KD3DC-125		12,500	14,00	107,00	60,00	45,00	41,25
KD3DC-127	12,700	14,00	107,00	60,00	45,00	40,95	
KD3DC-128	12,800	14,00	107,00	60,00	45,00	40,8	
KD3DC-130	13,000	14,00	107,00	60,00	45,00	40,5	
KD3DC-132	13,200	14,00	107,00	60,00	45,00	40,2	
KD3DC-135	13,500	14,00	107,00	60,00	45,00	39,75	
KD3DC-137	13,700	14,00	107,00	60,00	45,00	39,45	
KD3DC-140	14,000	14,00	107,00	60,00	45,00	39	
KD3DC-142	14,200	16,00	115,00	65,00	48,00	43,7	
KD3DC-145	14,500	16,00	115,00	65,00	48,00	43,25	
KD3DC-147	14,700	16,00	115,00	65,00	48,00	42,95	
KD3DC-150	15,000	16,00	115,00	65,00	48,00	42,5	
KD3DC-152	15,200	16,00	115,00	65,00	48,00	42,2	
KD3DC-155	15,500	16,00	115,00	65,00	48,00	41,75	
KD3DC-157	15,700	16,00	115,00	65,00	48,00	41,45	
KD3DC-160	16,000	16,00	115,00	65,00	48,00	41	

Ordering Code Bestellbezeichnung	Tool material Werk. material	Dimensions [mm] Abmessungen [mm]					
		d1	d2 h6	l1	l2	l3	tmax
KD3DC-165	Solid carbide with coating Vollhartmetall mit beschich- tung	16,500	18,00	123,00	73,00	48,00	48,25
KD3DC-170		17,000	18,00	123,00	73,00	48,00	47,5
KD3DC-175		17,500	18,00	123,00	73,00	48,00	46,75
KD3DC-180		18,000	18,00	123,00	73,00	48,00	46
KD3DC-185		18,500	20,00	131,00	79,00	50,00	51,25
KD3DC-190		19,000	20,00	131,00	79,00	50,00	50,5
KD3DC-195		19,500	20,00	131,00	79,00	50,00	49,75
KD3DC-200		20,000	20,00	131,00	79,00	50,00	49

Material group Werkstoffgruppe	Application Anwendungen
P	●
M	○
K	●
N	○
S	○
H	○

Web thinning $\geq \varnothing 3,000$; facet point grinding; main cutting edge form straight; optimised cutting geometry
 Ausspitzung $\geq \varnothing 3,000$; Flächenanschliff; Hauptschneidenform gerade; optimierte Schneidengeometrie

Structural and case hardened steels; free-cutting steels, heat-treatable steels;
 alloyed steels up to 1200 N/mm²; cast materials; bronze, brass; high-alloyed AlSi-alloys
 Bau- und Einsatzstähle; Automatenstähle, Vergütungsstähle;
 Stähle (legiert/unleg.) bis 1200 N/mm²; Gusswerkstoffe; Bronze, Messing; hochlegierte AlSi-Legierungen

- Main application Hauptanwendung
- Secondary application Sekundäre Anwendung

KD5DC...

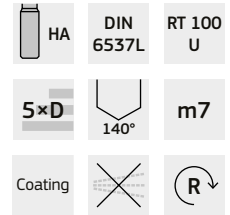
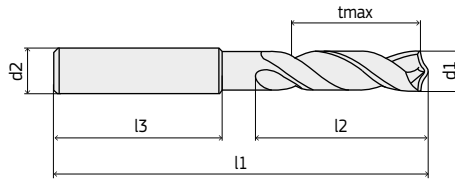

Ordering Code Bestellbezeichnung	Tool material Werk. material	Dimensions [mm] Abmessungen [mm]					
		d1	d2 h6	l1	l2	l3	tmax
KD5DC-030	Solid carbide with coating Vollhartmetall mit beschich- tung	3,000	6,00	66,00	28,00	36,00	23,5
KD5DC-031		3,100	6,00	66,00	28,00	36,00	23,35
KD5DC-032		3,200	6,00	66,00	28,00	36,00	23,2
KD5DC-033		3,300	6,00	66,00	28,00	36,00	23,05
KD5DC-034		3,400	6,00	66,00	28,00	36,00	22,9
KD5DC-035		3,500	6,00	66,00	28,00	36,00	22,75
KD5DC-036		3,600	6,00	66,00	28,00	36,00	22,6
KD5DC-037		3,700	6,00	66,00	28,00	36,00	22,45
KD5DC-038		3,800	6,00	74,00	36,00	36,00	30,3
KD5DC-039		3,900	6,00	74,00	36,00	36,00	30,15
KD5DC-040		4,000	6,00	74,00	36,00	36,00	30
KD5DC-041		4,100	6,00	74,00	36,00	36,00	29,85
KD5DC-042		4,200	6,00	74,00	36,00	36,00	29,7
KD5DC-043		4,300	6,00	74,00	36,00	36,00	29,55
KD5DC-044		4,400	6,00	74,00	36,00	36,00	29,4
KD5DC-045		4,500	6,00	74,00	36,00	36,00	29,25
KD5DC-046		4,600	6,00	74,00	36,00	36,00	29,1
KD5DC-0465		4,650	6,00	74,00	36,00	36,00	29,025
KD5DC-047		4,700	6,00	74,00	36,00	36,00	28,95
KD5DC-0476		4,760	6,00	82,00	44,00	36,00	36,86
KD5DC-048		4,800	6,00	82,00	44,00	36,00	36,8
KD5DC-049		4,900	6,00	82,00	44,00	36,00	36,65
KD5DC-050		5,000	6,00	82,00	44,00	36,00	36,5
KD5DC-051		5,100	6,00	82,00	44,00	36,00	36,35
KD5DC-052		5,200	6,00	82,00	44,00	36,00	36,2
KD5DC-053		5,300	6,00	82,00	44,00	36,00	36,05
KD5DC-054		5,400	6,00	82,00	44,00	36,00	35,9
KD5DC-050		5,500	6,00	82,00	44,00	36,00	35,75
KD5DC-0555		5,550	6,00	82,00	44,00	36,00	35,675
KD5DC-056		5,600	6,00	82,00	44,00	36,00	35,6
KD5DC-057		5,700	6,00	82,00	44,00	36,00	35,45
KD5DC-058		5,800	6,00	82,00	44,00	36,00	35,3
KD5DC-059		5,900	6,00	82,00	44,00	36,00	35,15
KD5DC-060		6,000	6,00	82,00	44,00	36,00	35
KD5DC-061		6,100	8,00	91,00	53,00	36,00	43,85
KD5DC-062		6,200	8,00	91,00	53,00	36,00	43,7
KD5DC-063		6,300	8,00	91,00	53,00	36,00	43,55
KD5DC-064		6,400	8,00	91,00	53,00	36,00	43,4
KD5DC-065		6,500	8,00	91,00	53,00	36,00	43,25
KD5DC-066		6,600	8,00	91,00	53,00	36,00	43,1
KD5DC-067		6,700	8,00	91,00	53,00	36,00	42,95
KD5DC-068		6,800	8,00	91,00	53,00	36,00	42,8
KD5DC-069		6,900	8,00	91,00	53,00	36,00	42,65
KD5DC-070		7,000	8,00	91,00	53,00	36,00	42,5
KD5DC-071		7,100	8,00	91,00	53,00	36,00	42,35
KD5DC-072		7,200	8,00	91,00	53,00	36,00	42,2
KD5DC-073	7,300	8,00	91,00	53,00	36,00	42,05	
KD5DC-074	7,400	8,00	91,00	53,00	36,00	41,9	
KD5DC-075	7,500	8,00	91,00	53,00	36,00	41,75	
KD5DC-076	7,600	8,00	91,00	53,00	36,00	41,6	

Ordering Code Bestellbezeichnung	Tool material Werk. material	Dimensions [mm] Abmessungen [mm]					
		d1	d2 h6	l1	l2	l3	tmax
KD5DC-077	Solid carbide with coating Vollhartmetall mit beschich- tung	7,700	8,00	91,00	53,00	36,00	41,45
KD5DC-078		7,800	8,00	91,00	53,00	36,00	41,3
KD5DC-079		7,900	8,00	91,00	53,00	36,00	41,15
KD5DC-080		8,000	8,00	91,00	53,00	36,00	41
KD5DC-081		8,100	10,00	103,00	61,00	40,00	48,85
KD5DC-082		8,200	10,00	103,00	61,00	40,00	48,7
KD5DC-083		8,300	10,00	103,00	61,00	40,00	48,55
KD5DC-084		8,400	10,00	103,00	61,00	40,00	48,4
KD5DC-085		8,500	10,00	103,00	61,00	40,00	48,25
KD5DC-086		8,600	10,00	103,00	61,00	40,00	48,1
KD5DC-087		8,700	10,00	103,00	61,00	40,00	47,95
KD5DC-088		8,800	10,00	103,00	61,00	40,00	47,8
KD5DC-089		8,900	10,00	103,00	61,00	40,00	47,65
KD5DC-090		9,000	10,00	103,00	61,00	40,00	47,5
KD5DC-091		9,100	10,00	103,00	61,00	40,00	47,35
KD5DC-092		9,200	10,00	103,00	61,00	40,00	47,2
KD5DC-093		9,300	10,00	103,00	61,00	40,00	47,05
KD5DC-094		9,400	10,00	103,00	61,00	40,00	46,9
KD5DC-095		9,500	10,00	103,00	61,00	40,00	46,75
KD5DC-096		9,600	10,00	103,00	61,00	40,00	46,6
KD5DC-097		9,700	10,00	103,00	61,00	40,00	46,45
KD5DC-098		9,800	10,00	103,00	61,00	40,00	46,3
KD5DC-099		9,900	10,00	103,00	61,00	40,00	46,15
KD5DC-100		10,000	10,00	103,00	61,00	40,00	46
KD5DC-101		10,100	12,00	118,00	71,00	45,00	55,85
KD5DC-102		10,200	12,00	118,00	71,00	45,00	55,7
KD5DC-103		10,300	12,00	118,00	71,00	45,00	55,55
KD5DC-104		10,400	12,00	118,00	71,00	45,00	55,4
KD5DC-105		10,500	12,00	118,00	71,00	45,00	55,25
KD5DC-106		10,600	12,00	118,00	71,00	45,00	55,1
KD5DC-107		10,700	12,00	118,00	71,00	45,00	54,95
KD5DC-108		10,800	12,00	118,00	71,00	45,00	54,8
KD5DC-109		10,900	12,00	118,00	71,00	45,00	54,65
KD5DC-110		11,000	12,00	118,00	71,00	45,00	54,5
KD5DC-111		11,100	12,00	118,00	71,00	45,00	54,35
KD5DC-112		11,200	12,00	118,00	71,00	45,00	54,2
KD5DC-113		11,300	12,00	118,00	71,00	45,00	54,05
KD5DC-114		11,400	12,00	118,00	71,00	45,00	53,9
KD5DC-115		11,500	12,00	118,00	71,00	45,00	53,75
KD5DC-116		11,600	12,00	118,00	71,00	45,00	53,6
KD5DC-117		11,700	12,00	118,00	71,00	45,00	53,45
KD5DC-118		11,800	12,00	118,00	71,00	45,00	53,3
KD5DC-119		11,900	12,00	118,00	71,00	45,00	53,15
KD5DC-120		12,000	12,00	118,00	71,00	45,00	53
KD5DC-122		12,200	14,00	124,00	77,00	45,00	58,7
KD5DC-125		12,500	14,00	124,00	77,00	45,00	58,25
KD5DC-127		12,700	14,00	124,00	77,00	45,00	57,95
KD5DC-130	13,000	14,00	124,00	77,00	45,00	57,5	
KD5DC-135	13,500	14,00	124,00	77,00	45,00	56,75	
KD5DC-137	13,700	14,00	124,00	77,00	45,00	56,45	
KD5DC-140	14,000	14,00	124,00	77,00	45,00	56	
KD5DC-142	14,200	16,00	133,00	83,00	48,00	61,7	
KD5DC-145	14,500	16,00	133,00	83,00	48,00	61,25	
KD5DC-147	14,700	16,00	133,00	83,00	48,00	60,95	
KD5DC-150	15,000	16,00	133,00	83,00	48,00	60,5	
KD5DC-152	15,200	16,00	133,00	83,00	48,00	60,2	
KD5DC-155	15,500	16,00	133,00	83,00	48,00	59,75	
KD5DC-157	15,700	16,00	133,00	83,00	48,00	59,45	
KD5DC-160	16,000	16,00	133,00	83,00	48,00	59	
KD5DC-165	16,500	18,00	143,00	93,00	48,00	68,25	
KD5DC-170	17,000	18,00	143,00	93,00	48,00	67,5	

Ordering Code Bestellbezeichnung	Tool material Werk. material	Dimensions [mm] Abmessungen [mm]					
		d1	d2 h6	l1	l2	l3	tmax
KD5DC-175	Solid carbide with coating Vollhartmetall mit beschich- tung	17,500	18,00	143,00	93,00	48,00	66,75
KD5DC-180		18,000	18,00	143,00	93,00	48,00	66
KD5DC-185		18,500	20,00	153,00	101,00	50,00	73,25
KD5DC-190		19,000	20,00	153,00	101,00	50,00	72,5
KD5DC-195		19,500	20,00	153,00	101,00	50,00	71,75
KD5DC-200		20,000	20,00	153,00	101,00	50,00	71

Material group Werkstoffgruppe	Application Anwendungen
P	●
M	○
K	●
N	○
S	○
H	○

Web thinning $\geq \varnothing 3,000$; facet point grinding; main cutting edge form straight; optimised cutting geometry
 Ausspitzung $\geq \varnothing 3,000$; Flächenanschliff; Hauptschneidenform gerade; optimierte Schneidengeometrie

Structural and case hardened steels; free-cutting steels, heat-treatable steels;
 alloyed steels up to 1200 N/mm²; cast materials; bronze, brass; high-alloyed AlSi-alloys
 Bau- und Einsatzstähle; Automatenstähle, Vergütungsstähle;
 Stähle (legiert/unleg.) bis 1200 N/mm²; Gusswerkstoffe; Bronze, Messing; hochlegierte AlSi-Legierungen

- Main application Hauptanwendung
- Secondary application Sekundäre Anwendung

Cutting Values
Schneidwerte

Drill Ø [mm]	Feed column No. f [mm/rev] Feed column No. f [mm/rev]								
	1	2	3	4	5	6	7	8	9
0,50	0,004	0,006	0,007	0,008	0,010	0,012	0,014	0,016	0,019
1,00	0,006	0,008	0,012	0,014	0,016	0,018	0,020	0,023	0,025
2,00	0,020	0,025	0,032	0,040	0,050	0,063	0,080	0,100	0,125
2,50	0,025	0,032	0,040	0,050	0,063	0,080	0,100	0,125	0,160
3,15	0,032	0,040	0,050	0,063	0,080	0,100	0,125	0,160	0,160
4,00	0,040	0,050	0,063	0,080	0,100	0,125	0,160	0,200	0,200
5,00	0,040	0,050	0,063	0,080	0,100	0,125	0,160	0,200	0,250
6,30	0,050	0,063	0,080	0,100	0,125	0,160	0,200	0,250	0,315
8,00	0,063	0,080	0,100	0,125	0,160	0,200	0,250	0,315	0,315
10,00	0,080	0,100	0,125	0,160	0,200	0,250	0,315	0,400	0,400
12,50	0,080	0,100	0,125	0,160	0,200	0,250	0,315	0,400	0,500
16,00	0,100	0,125	0,160	0,200	0,250	0,315	0,400	0,500	0,630
20,00	0,125	0,160	0,200	0,250	0,315	0,400	0,500	0,630	0,630
25,00	0,160	0,200	0,250	0,315	0,400	0,500	0,630	0,800	0,800
31,50	0,160	0,200	0,250	0,315	0,400	0,500	0,630	0,800	1,000
40,00	0,200	0,250	0,315	0,400	0,500	0,630	0,800	1,000	1,250
50,00	0,250	0,310	0,400	0,500	0,630	0,800	1,000	1,250	1,250
63,00	0,315	0,400	0,500	0,630	0,800	1,000	1,250	1,600	1,600
80,00	0,400	0,500	0,630	0,800	1,000	1,250	1,600	1,600	2,000

Tools with bold feed column No. are preferred choice.

Werkzeuge mit fettgedruckter Vorschubreihen-Nr. sind bevorzugt auszuwählen.

Coolant Kühlung

- Air Luft
- Neat oil Öl
- ◎ Soluble oil Emulsion

Material group Werkstoffgruppe	Material examples (figures in bold = material no. to DIN EN 10 027) Werkstoffbeispiele (Fettgedruckte Zahlen = Werkstoff-Nr. nach DIN EN)	Tensile strength Zugfestigkeit [N/mm²]	Hardness Härte	Coolant Kühlung
P	Common structural steels Allgemeine Baustähle	1.0035 S185(St33), 1.0486 P275N(StE285), 1.0345 P235GH(H1), 1.0425 P265GH(H2)	≤500	○
	Free-cutting steels Automatenstähle	1.0050 E295 (St50-2), 1.0070 E360 (St70-2), 1.8937 P500NH (WStE500)	≤1000	○
	Unalloyed heat-treatable steels Unlegierte Vergütungsstähle	1.0718 11SMnPb30 (95MnPb28), 1.0736 11SMn37 (95Mn36)	≤850	○
		1.0727 46S20 (45S20), 1.0728 (60S20), 1.0757 46SPb20 (45SPb20)	≤1000	○
		1.0402 C22, 1.1178 C30E (Ck30)	≤700	○
	Alloyed heat-treatable steels Legierte Vergütungsstähle	1.0503 C45, 1.1191 C45E (Ck45)	≤850	○
		1.0601 C60, 1.1221 C60E (Ck60)	≤1000	○
		1.5131 50MnSi4, 1.7003 38Cr2, 1.7030 28Cr4	≤1000	○
	Unalloyed case hard. steels Unlegierte Einsatzstähle	1.5710 36NiCr6, 1.7035 41Cr4, 1.7225 42CrMo4	≤1400	○
		1.0301 (C10), 1.1121 C10E (Ck10)	≤850	○
		1.7276 10CrMo11, 1.5125 11MnSi6	≤1000	●
	Alloyed case hardened steels Legierte Einsatzstähle	1.5752 15NiCr13, 1.7131 16MnCr5, 1.7264 20CrMo5	≤1400	●
		1.8504 34CrAl6	≤1000	○
	Nitriding steels Nitrierstähle	1.8519 31CrMoV9, 1.8550 34CrAlNi7	≤1400	●
	Tool steels Werkzeugstähle	1.1750 C75W, 1.2067 102Cr6, 1.2307 29CrMoV9	≤850	○
1.2080 X210Cr12, 1.2083 X42Cr13, 1.2419 105WCr6, 1.2767 X45NiCrMo4		≤1400	●	
High speed steels Schnellarbeitsstähle	1.3243 S 6-5-2-5, 1.3343 S 6-5-2, 1.3344 S 6-5-3	≤1400	●	
Spring steels Federstähle	1.5026 55Si7, 1.7176 55Cr3, 1.8159 51CrV4 (51CrV4)	≤350 HB	●	
M	Stainless steels Rostfreie Stähle	1.4005 X12CrS13, 1.4104 X14CrMoS17, 1.4105 X6CrMoS17, 1.4305 X8CrNiS18-9	≤900	●
	Sulphured Geschwefelt	1.4301 X5CrNi18-10 (V2A), 1.4541 X6CrNiTi18-10, 1.4571 X6CrNiMoTi 17-12-2 (V4A)	≤1100	●
		Martensitic Martensitisch	1.4057 X20CrNi172 (X17CrNi16-2), 1.4122 X39CrMo17-1, 1.4521 X2CrMoTi18-2	≤1500
K	Cast iron Gusseisen	0.6010 EN-GJL-100 (GG10), 0.6020 EN-GJL-200 (GG20)	≤240 HB	○ ○
	Spheroidal graphite iron and malleable cast iron Kugelgraphit- und Temperguss	0.6025 EN-GJL-250 (GG25), 0.6035 EN-GJL-350 (GG35)	≤350 HB	○ ○
		0.7050 EN-GJS-500-7 (GGG50), 0.8035 EN-GJMW-350-4 (GTW35)	≤240 HB	○
	Chilled cast iron Hartguss	0.7070 EN-GJS-700-2 (GGG70), 0.8170 EN-GJMB-700-2 (GTS70)	≤350 HB	○
	New cast materials GGV Neue Gusswerkstoffe GGV	-	≤350 HB	○
	New cast materials ADI Neue Gusswerkstoffe ADI	EN-GJV250 (GGV25), EN-GJV350 (GGV35)	≤220 HB	○ ○
		EN-GJV400 (GGV40), EN-GJV500 (GGV50), SiMo 6	≤300 HB	○ ○
N	Aluminium and Al-alloys Aluminium und Al-Legierungen	EN-GJS-800-8 (ADI800), EN-GJS-1000-5 (ADI1000)	≤1000	○ ○
	Al wrought alloys Al-Knetlegierungen	EN-GJS-1200-2 (ADI1200), EN-GJS-1400-1 (ADI1400)	≤1400	○ ○
	Al cast alloys Al-Gusslegierungen	3.0255 Al99,5, 3.2315 AlMgSi1, 3.3515 AlMg1	≤400	○
	Magnesium alloys Magnesium-Legierungen	3.0615 AlMgSiPb, 3.1325 AlCuMg1, 3.3245 AlMg3Si, 3.4365 AlZnMgCu1,5	≤650	○
		3.2131 G-AlSi5Cu1, 3.2153 G-AlSi7Cu3, 3.2573 G-AlSi9	≤600	○
	Copper, low-alloyed Kupfer, niedriglegiert	3.2581 G-AlSi12, 3.2583 G-AlSi12Cu, - G-AlSi12CuNiMg	≤600	○
	Brass Messing	3.5200 MgMn2, 3.5812.05 G-MgAl8Zn1, 3.5612.05 G-MgAl6Zn1	≤400	○
		2.0070 SE-Cu, 2.1020 CuSn6, 2.1096 G-CuSn5ZnPb	≤500	○
		2.0380 CuZn39Pb2, 2.0401 CuZn39Pb3, 2.0410 CuZn43Pb2	≤600	○
		2.0250 CuZn20, 2.0280 CuZn33, 2.0332 CuZn37Pb0,5	≤600	○
		2.1090 CuSn7ZnPb, 2.1170 CuPb5Sn5, 2.1176 CuPb10Sn	≤600	○ ●
		2.0790 CuNi18Zn19Pb	≤850	●
	Bronze Bronzen	2.0916 CuAl5, 2.0960 CuAl9Mn, 2.1050 CuSn10	≤850	●
		2.0980 CuAl11Ni, 2.1247 CuBe2	≤1000	●
		2.0980 CuAl11Ni, 2.1247 CuBe2	≤1000	●
S	Special alloys Sonderlegierungen	Nimonic, Inconel, Monel, Hastelloy	≤2000	●
	Ti and Ti-alloys Titan und Titanlegierungen	3.7024 Ti99,5, 3.7114 TiAl5Sn2,5, 3.7124 TiCu2	≤850	●
	3.7154 TiAl6Zr5, 3.7165 TiAl6V4, 3.7184 TiAl4Mo4Sn2,5, - TiAl8Mo1V1	≤1400	●	
H	Hardened steels Gehärtete Stähle	-	≤48 HRC	●
	Duroplastics Duroplastisch	Epoxy resin, Resopal, Pertinax, Moltopren	≤150	○
	Thermoplastics Thermoplastisch	Plexiglass, Hostalen, Novodur, Makralon	≤100	○ ○
	Kevlar Aramidfaserverstärkt	Kevlar	≤1000	○
	Glass, carbon concentr. plastics Glas-/kohlefaserverstärkt	GFK/CFK	≤1000	○

KD3D-...



KD3DC-...

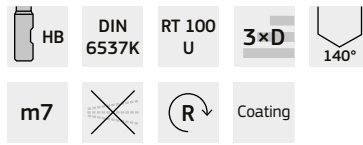

KD5DC-...

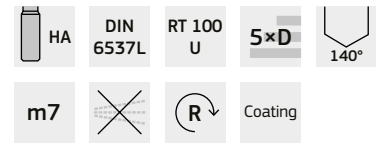

v_c [m/min]	Feed col. No. Vorschubreihen Nr.
80	4
70	4
80	5
70	4
80	4
70	4
60	4
60	4
80	5
60	4
50	4
50	3
25	2
25	2
15	1
25	2
90	4
80	4
80	4
70	4
10	3
200	7
200	7
150	6
120	6
180	6
80	5
180	5
180	5
120	5
120	5
70	4
50	3
15	2
15	1
15	1
20	3
10	
50	4
40	3
80	3

v_c [m/min]	Feed col. No. Vorschubreihen Nr.
130	7
110	6
145	8
110	7
120	7
110	7
105	7
105	7
100	6
130	8
120	7
85	5
100	6
90	5
65	6
55	5
55	
45	3
40	2
15	1
35	2
210	8
155	8
155	7
125	7
35	3
260	9
260	9
220	8
180	8
260	8
105	7
270	8
180	7
105	6
85	6
80	5
60	5
25	4
15	1
15	1
40	1
20	1

v_c [m/min]	Feed col. No. Vorschubreihen Nr.
130	7
110	6
145	8
110	7
120	7
110	7
105	7
105	7
100	6
130	8
120	7
85	5
100	6
90	5
65	6
55	5
55	
45	3
45	2
15	1
35	2
210	8
155	8
145	7
125	7
35	3
260	9
260	9
235	9
170	8
260	8
105	7
270	8
180	7
105	6
85	6
80	5
60	5
25	4
15	1
15	1
35	1
20	1

Ramping

Rampe eintauchen

Face Milling Cutter Aufsteckfräser		BF45	BF90	
Bevel angle W_1 max. for plunge milling "ramping" Schrägungswinkel W_1 max beim Rampe eintauchen (Ramping)	d	12,7	6,65	9,52
	b	1,4		
	$a_{p \max}$	5,5	8	14
	d_1 [mm]	W_1 max [degree grad]		
	40	8,5	1,0	1,5
	50	6,5	0,8	1,1
	63	5,0	0,6	0,8
	80	3,5	0,5	0,6
	100	3,0		0,5
		Internal cutting depth Innere Schnittiefe $0,7 \times a_{p \max}$		

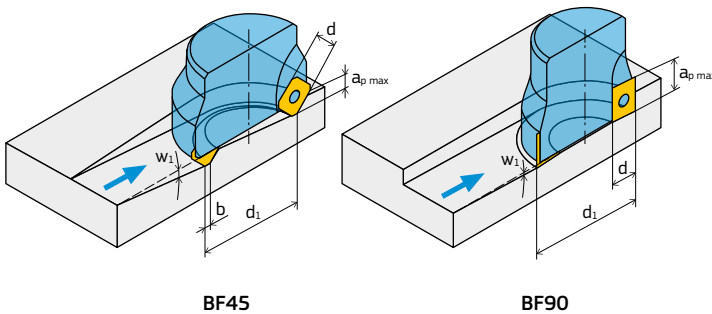

End milling cutter Schafffräser	BE90			
Bevel angle W_1 max. for plunge milling "ramping" Schrägungswinkel W_1 max beim Rampe eintauchen (Ramping)	d_1	l_2	d	W_1 max [degree grad]
	16	8	6,65	3,0
	20	8	6,65	2,1
	25	8	6,65	1,5
	25	14	9,52	2,8
	32	14	9,52	2,0
	40	14	9,52	1,5

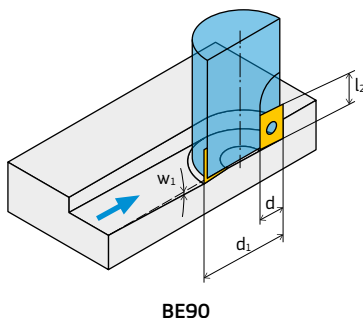

Formulas

Formeln

Revolutions Drehzahl

$$n = \frac{v_c \cdot 1000}{\pi \cdot d_1} \text{ [rev/min]}$$

Cutting speed Schnittgeschwindigkeit

$$v_c = \frac{\pi \cdot n \cdot d_1}{1000} \text{ [m/min]}$$

Feed rate Vorschubgeschwindigkeit

$$v_f = f_z \cdot z_{\text{eff}} \cdot n \text{ [mm/min]}$$

Feed per tooth Vorschub pro Zahn

$$f_z = \frac{v_f}{z_{\text{eff}} \cdot n} \text{ [mm]}$$

Chip volume Spanvolumen

$$Q = \frac{a_e \cdot a_p \cdot v_f}{1000} \text{ [cm}^3\text{/min]}$$

Drive power Antriebsleistung

$$P_e = \frac{Q}{LF} \text{ [kW]}$$

Units Variablen		
v_c	Cutting speed Schnittgeschwindigkeit	m/min
n	Revolution Drehzahl	[rev/min]
d_1	Cutter diameter Fräser-Durchmesser	mm
v_f	Feed rate Vorschubgeschwindigkeit	mm/min
f_z	Feed per tooth Vorschub pro Zahn	mm/tooth
P_e	Drive power Antriebsleistung	[kW]
z_{eff}	Effective number of teeth Effektive Zähnezahl	
Q	Chip volume Spanvolumen	cm ³ /min
a_e	Width of cut Schnittbreite	mm
a_p	Depth of cut Schnittiefe	mm
LF	Efficiency factor Leistungsfaktor	cm ³ /min/kW

Calculation of Approach Angle φ_s
Berechnung des Eingriffswinkels φ_s

Centerline location Mittige Anordnung

$$\varphi_s = 2 \cdot \sin^{-1} \left(\frac{a_e}{d_1} \right)$$

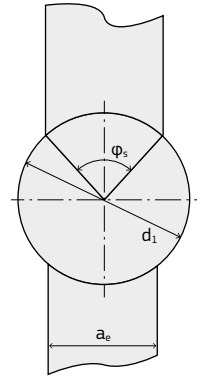

Edge milling Kanten fräsen

$$\varphi_s = \sin^{-1} \left(\frac{a_e - \frac{1}{2} d_1}{\frac{1}{2} d_1} \right) + 90$$

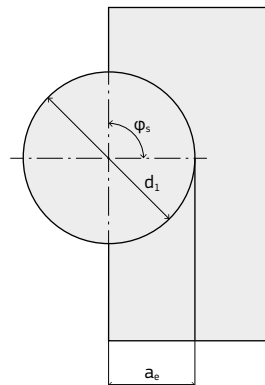

Adjusted milling Versetzt fräsen

$$\sin \varphi_1 = \frac{2 \cdot \left(\frac{d_1}{2} - a_{ue} \right)}{d_1}$$

$$\sin \varphi_2 = \frac{2 \cdot (a_e - a_{e1})}{d_1}$$

$$\sin \varphi_s = \sin \varphi_1 + \sin \varphi_2$$

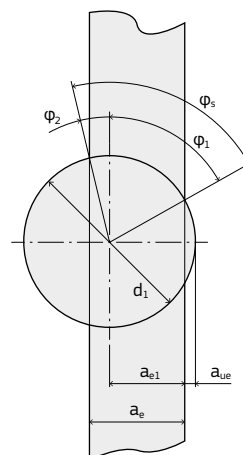

Dimensions, units and application formulas

Maße, Einheiten, Anwendungsformeln

Dimensions and Units Maße und Einheiten			Application Formulas Anwendungsformeln											
a_p	Depths of cut Schnitttiefe	mm	Revolutions per minute Umdrehungen pro Minute	Medium chip thickness Mittlere Spandicke										
a_e	Width of cut Schnittbreite	mm	$n = \frac{v_c \cdot 1000}{\pi \cdot d_e} \text{ [rev/min U/min]}$	$h_m = f_z \frac{a_e}{d_e} \text{ [mm]}$										
l	Machined length Bearbeitete Länge	mm												
h_m	Medium chip thickness Mittenspandicke	mm	Feed rate Vorschubgeschwindigkeit	valid only up to gültig nur bis $\frac{a_e}{d_e} < 0,3$										
v_c	Cutting speed Schnittgeschwindigkeit	m/min	$v_f = f_z \cdot z \cdot n \text{ [mm/min]}$	respectively 30 % or $\phi = 60^\circ$ bzw. 30 % oder $\phi = 60^\circ$										
f_z	Feed per tooth Vorschub pro Zahn	mm/tooth		otherwise sonst $h_m = \frac{360 \cdot f_z \cdot a_e \cdot \sin(k)}{\pi \cdot d_e \cdot \phi_s}$										
d_1	External tool diameter Äußerer Werkzeugdurchmesser	mm	Feed per revolution Vorschub pro Umdrehung	Chip removal rate Zerspanungsvolumen										
d_e	Effective diameter with different inserts and at specified cut depth Effektiver Durchmesser, Schnittkreisdurchmesser	mm	$f = \frac{v_f}{n} \text{ [mm/rev mm/U]}$	$Q = \frac{a_p \cdot a_e \cdot v_f}{1000} \text{ [cm}^3\text{/min]}$										
d	Insert diameter Durchmesser der Platte	mm	Feed per tooth Vorschub pro Zahn	Effective diameter of cutting Effektiver Schnittkreisdurchmesser										
z	Number of tool cutting edges Anzahl der Schneiden am Werkzeug		$f_z = h_m \sqrt{\frac{d_e}{a_e}} \text{ [mm/tooth mm/z]}$	$d_e = d_1 - d + 2 a_p \sqrt{(d - a_p)} \text{ [mm]}$										
k	Setting angle Einstellwinkel													
ϕ_s	Approach angle Eingriffswinkel		valid only up to gültig nur bis $\frac{a_e}{d_e} < 0,3$ respectively 30 % or $\phi = 60^\circ$ bzw. 30 % oder $\phi = 60^\circ$											
			<table border="1"> <thead> <tr> <th>Setting angle Einstellwinkel k</th> <th>Feed per tooth Vorschub pro Zahn f_z</th> </tr> </thead> <tbody> <tr> <td>90°</td> <td>f_z</td> </tr> <tr> <td>45°</td> <td>1,414 f_z</td> </tr> <tr> <td>30°</td> <td>2 f_z</td> </tr> <tr> <td colspan="2">otherwise sonst $f_z = \frac{h_m \cdot \pi \cdot d_e \cdot \phi_s}{360 \cdot a_e \cdot \sin(k)}$</td> </tr> </tbody> </table>	Setting angle Einstellwinkel k	Feed per tooth Vorschub pro Zahn f_z	90°	f_z	45°	1,414 f_z	30°	2 f_z	otherwise sonst $f_z = \frac{h_m \cdot \pi \cdot d_e \cdot \phi_s}{360 \cdot a_e \cdot \sin(k)}$		
Setting angle Einstellwinkel k	Feed per tooth Vorschub pro Zahn f_z													
90°	f_z													
45°	1,414 f_z													
30°	2 f_z													
otherwise sonst $f_z = \frac{h_m \cdot \pi \cdot d_e \cdot \phi_s}{360 \cdot a_e \cdot \sin(k)}$														

Solutions of Problems in Milling
 Lösungen von Problemen beim Fräsen

Removal and solutions Abhilfe und Lösungen	Problem Problem										
	Flank wear Freiflächenverschleiß	Crater wear Kolkverschleiß	Flaking Plattenabsplittierungen	Thermal cracks Kammerisse	Fatigue cracks Ermüdungsrisse	Plastic deformation Plastische Verformung	Notch wear Kerbverschleiß	Built-up edge Aufbauschniedenbildung	Cutting edge failure Schneidkantenbruch	Vibrations Vibrationen	Poor surface quality Schlechte Oberflächenqualität
Carbide grade with higher wear resistance Verschleißfestere HM-Sorte	•	•				•	•				•
Tougher carbide grade Zähere HM-Sorte			•	•	•				•		
Increase cutting speed Schnittgeschwindigkeit erhöhen			•					•			
Reduce cutting speed Schnittgeschwindigkeit verringern	•	•		•		•					
Increase feed per tooth Vorschub pro Zahn erhöhen	•							•		•	
Reduce feed per tooth Vorschub pro Zahn verringern			•	•	•	•	•		•		•
Change cutter position Fräserpositionierung ändern					•					•	
Smaller cutter diameter Kleinerer Fräserdurchmesser				•							
Improve rigidity Stabilität verbessern			•				•		•		
Use coated grade Verwendung einer beschichteten Sorte	•	•						•			
Use coolant Kühlmittel verwenden				•		•					

Material Comparison Chart
Werkstoffe – Vergleichstabelle

Material group Werkstoffgruppe	Germany Deutschland		Great Britain Großbritannien		France Frankreich	Italy Italien	USA USA	Russia Russland
	W-Nr.	DIN	BS	EN	AFNOR	UNI	AISI/SAE	
P	Constructional steels Baustahl und Konstruktionsstahl							
	1.0401	C15	080M15	–	CC12	C15C16	1015	15
	1.0402	C22	050A20	2C	CC20	C20C21	1020	20
	1.0501	C35	060A35	–	CC35	C35	1035	35
	1.0503	C45	080M46	–	CC45	C45	1045	45
	1.0535	C55	070M55	–	–	C55	1055	55
	1.0601	C60	080A62	43D	CC55	C60	1060	60
	1.0715	9SMn28	230M07	–	S250	CF9SMn28	1213	
	1.0718	9SMnPb28	–	–	S250Pb	CF9SMnPb28	12L13	
	1.0722	10SPb20	–	–	10PbF2	CF10SPb20	–	A12
	1.0726	35S20	212M36	8M	35MF4	–	1140	A30
	1.0736	9SMn36	240M07	1B	S300	CF9SMn36	1215	
	1.0737	9SMnPb36	–	–	S300Pb	CF9SMnPb36	12L14	
	1.0904	55Si7	250A53	45	55S7	55Si8	9255	55C2
	1.0961	60SiCr7	–	–	60SC7	60SiCr8	9262	60C2
	1.1141	Ck15	080M15	32C	XC12	C16	1015	
	1.1157	40Mn4	150M36	15	35M5	–	1039	40Г
	1.1158	Ck25	–	–	–	–	1025	25
	1.1167	36Mn5	–	–	40M5	–	1335	35ГЛ
	1.1170	28Mn6	150M28	14A	20M5	C28Mn	1330	35Г2
	1.1183	Cf35	060A35	–	XC38TS	C36	1035	
	1.1191	Ck45	080M46	–	XC42	C45	1045	45
	1.1203	Ck55	070M55	–	XC55	C50	1055	55
	1.1213	Cf53	060A52	–	XC48TS	C53	1050	50
	1.1221	Ck60	080A62	43D	XC60	C60	1060	60Г
	1.1274	Ck101	060A96	–	–	–	1095	
	1.3401	X120Mn12	Z120M12	–	Z120M12	XG120Mn12	–	
	1.3505	100Cr6	534A99	31	100C6	100Cr6	52100	ШХ15
	1.5415	15Mo3	1501-240	–	15D3	16Mo3KW	ASTM A204Gr.A	15HM
	1.5423	16Mo5	1503-245-420	–	–	16Mo5	4520	
	1.5622	14Ni6	–	–	16N6	14Ni6	ASTM A350LF5	15ГНЛ
	1.5662	X8Ni9	1501-509; 510	–	–	X10Ni9	ASTM A353	
	1.5680	12Ni19	–	–	Z18N5	–	2515	15ГН4М
	1.5710	36NiCr6	640A35	111A	35NC6	–	3135	35ХН2МЛ
	1.5732	14NiCr10	–	–	14NC11	16NiCr11	3415	12ХН3А
	1.5752	14NiCr14	655M13; 655A12	36A	12NC15	–	3415; 3310	20ХН4ФА
	1.6511	36CrNiMo4	816M40	110	40NCD3	38NiCrMo4(KB)	9840	40ХН2МА
	1.6523	21NiCrMo2	805M20	362	20NCD2	20NiCrMo2	8620	20ХГНМ
	1.6546	40NiCrMo22	311 – Type 7	–	–	40NiCrMo2(KB)	8740	
	1.6582	34CrNiMo6	817M40	24	35NCD6	35NiCrMo6(KB)	4340	38Х2Н2МА
	1.6587	17CrNiMo6	820A16	–	18NCD6	–	–	18Х2Н4ВА
	1.6657	14NiCrMo134	832M13	36C	–	15NiCrMo13	–	18Х2Н4МА
1.7015	15Cr3	523M15	–	12C3	–	5015	15X	
1.7033	34Cr4	530A32	18B	32C4	34Cr4(KB)	5132	35X	
1.7035	41Cr4	530M40	18	42C4	41Cr4	5140	40X	
1.7045	42Cr4	–	–	–	–	5140		
1.7131	16MnCr5	(527M20)	–	16MC5	16MnCr5	5115	18ХГ	
1.7176	55Cr3	527A60	48	55C3	–	5155	50ХГА	
1.7218	25CrMo4	1717CDS110	–	25CD4	25CrMo4(KB)	4130	20ХМ	
1.7220	34CrMo4	708A37	19B	35CD4	35CrMo4	4137;4135	35ХМ	
1.7223	41CrMo4	708M40	19A	42CD4TS	41CrMo4	4140;4142	38ХМА	
1.7225	42CrMo4	708M40	19A	42CD4	42CrMo4	4140	40ХН2МА	

Material Comparison Chart
Werkstoffe – Vergleichstabelle

Material group Werkstoffgruppe	Germany Deutschland		USA USA	France Frankreich	Italy Italien	Great Britain Großbritannien	European Standard Europa Norm	Russia Russland
	W-Nr.	DIN	AISI/SAE	AFNOR	UNI	BS	EN	
N	Non-ferrous heavy metal alloys NE-Schwermetall-Legierungen							
	2.0321	CuZn37(Ms63)	C27400	CuZn37	P-CuZn37	CZ 108	CW508L	
	2.0402	CuZn40Pb2 (Ms58)	C37700	CuZn39Pb2	P-CuZn3940Pb2	CZ 122	CW617N	
	2.0872	CuNi10Fe1Mn	C70600	CuNi10Fe1Mn	Pt-CuNi10Fe1Mn	CZ 135	CW352H	
	2.0920	CuAl8			P-CuAl8			
	2.0932	CuAl8Fe3	C61400	CuAl7Fe2	P-CuAl8Fe3	CA106	CW303G	
	2.0966	CuAl10Ni5Fe4	C63000	CuAl10Ni5Fe4		CA104	CW307G	
	2.0975	CuAl10Ni	C95800	CuAl10Fe5Ni5	CuAl11Fe4Ni4	AB2		
	2.1020	CuSn6	C51900	CuSn6P	CuSn7	PB103	CW452K	
	2.1498	CuSP			CuS(P0,01)			
	2.3205	PbSb5						
	2.3290	PbSb9						
	Light metal alloys Leichtmetall-Legierungen							
	3.1355	AlCuMg2	AA 2024	2024	2024	2024	AW-2024	
	3.1645	AlCuMgPb					AW-2007	
	3.2581.01	AlSi12	B413.0	A-S 13	3051/G-AS9MG	LM6	AC-44200	
	3.3527	AlMg2Mn0,8					AW-5049	
	3.3535	AlMg3	AA 5754	5754			AW-5754	
	3.4365	AlZnMgCu1,5	AA 7075	7075	7075	7075	AW-7075	
3.5312	MgAl3Zn	AZ31B	G-A3Z1			MAG-E-111	MG-P-62	
3.5161	MgZn6Zr	ZK60A				MAG-E-161		
3.5194	MgAl9Zn1	AZ91	G-A9Z1			MAG 7	MC-21120	
3.7115	Ti-5Al-2,5Sn	Grade 6			T-A5E			
3.7165	Ti-6Al-4V	Grade 5			T-A6V	TA10-13	Ti P63	
3.7174	Ti-6Al-6V-2Sn	4971					Ti P64	

Material group Werkstoffgruppe	Tradename Handelsname	Germany Deutschland	USA USA	France Frankreich	Italy Italien	Great Britain Großbritannien	European Standard Europa Norm	Russia Russland
		DIN	AISI/SAE	AFNOR	UNI	BS	EN	
S	High-temperature materials Hochwarmfeste Werkstoffe							
	HS-27	NiCo32Cr26Mo			KC20WN			
	Hastelloy-C	NiMo16Cr15W	B366	NC17DWY	N01276		DIN 2.4819	
	Inconel 718	NiCr19NbMo	5662		N07718	HR8	DIN 2.4668	
	Lescalloy	NiCr16FeTi						
	Nimonic90	NiCr20Co18Ti			N07090		DIN 2.4632	
	Unitemp	NiCr16Co8WAlTi						
	Vakumell	NiCr20TiAl						
	Vakumelt	NiCo10Cr9WAlTi						
Alloy 625	NiCr22Mo9N	5599			N06625	NA21	DIN 2.4856	



PRODUCER

KONRAD TOOLS

Ing. Jan Konrad

TMC CR, s.r.o.

Masná 27/9, 602 00 Brno

Czech Republic

www.konradtools.com