

## Radial-Stechdrehen gerade

Radial groove turning straight

Utensile dritto – Scanalatura e copiatura radiale

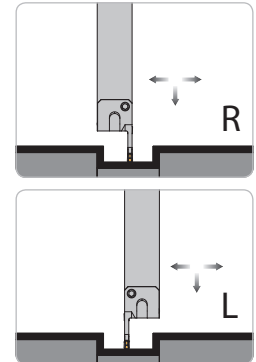
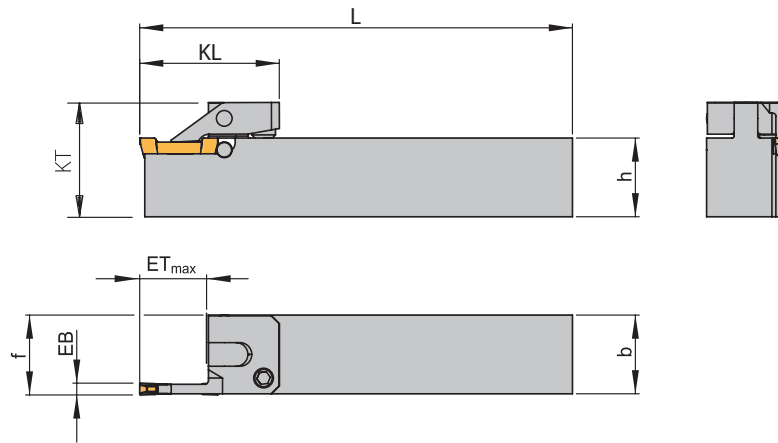

Rechte Ausführung abgebildet  
Right-hand execution shown  
Versione destra in figura

## Grundhalter / Basic holder / Corpo utensile

Bezeichnung Designation Articolo	EB	ET <sub>max</sub>	f	L	KL	KT	b	h	Schneideinsatz Insert Inserto
SAN01-0317-1616 R/L	3	17	16,3	100	35,5	25	16	16	320....
SAN01-0317-2020 R/L	3	17	20,3	110	35,5	29	20	20	320....
SAN01-0317-2525 R/L	3	17	25,3	125	35,5	34	25	25	320....
SAN01-0419-1616 R/L	4	19	16,3	100	37,6	25	16	16	422....
SAN01-0419-2020 R/L	4	19	20,3	110	37,6	29	20	20	422....
SAN01-0419-2525 R/L	4	19	25,3	125	37,6	34	25	25	422....
SAN01-0522-2020 R/L	5	22	20,3	110	40,6	29	20	20	525....
SAN01-0522-2525 R/L	5	22	25,3	125	40,6	34	25	25	525....
SAN01-0627-2020 R/L	6	27	20,3	110	45,7	29	20	20	630....
SAN01-0627-2525 R/L	6	27	25,3	125	45,7	34	25	25	630....

**Form B1 – kurz / Form B1 – short / Forma B1 – corta**

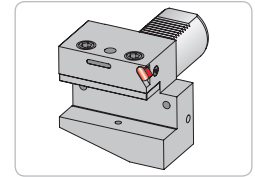
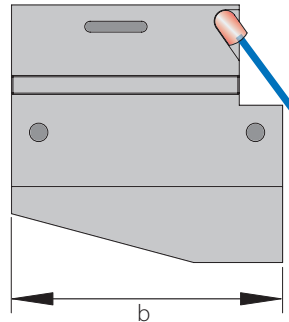
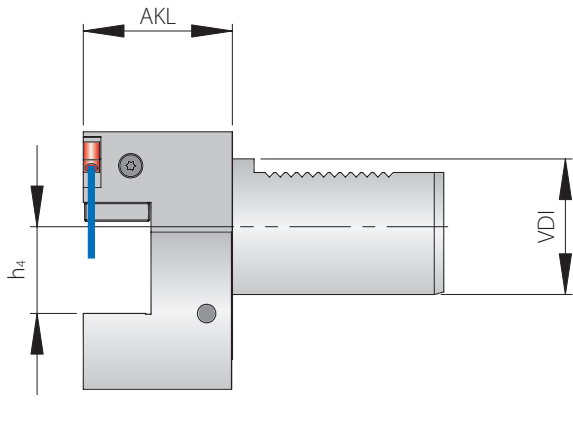

**Grundhalter / Basic holder / Adattatore**

Bezeichnung Designation Articolo	VDI	h4	AKL	b	Kühlmitteldüse Coolant jet Ugello refrigerante	Schraube für Kühlmitteldüse Screw for coolant jet Vite per ugello refrigerante
KMH01-B1-16X12X24	16	12	24	42	KMD0519	AS0020
KMH01-B1-20X16X30	20	16	30	55	KMD0519	AS0020
KMH01-B1-25X16X30	25	16	30	55	KMD0519	AS0020
KMH01-B1-30X20X40	30	20	40	70	KMD0830	AS0020
KMH01-B1-40X25X44	40	25	44	85	KMD0830	AS0020
KMH01-B1-50X32X55	50	32	55	100	KMD0830	AS0020

**Form B2 – kurz / Form B2 – short / Forma B2 – corta**

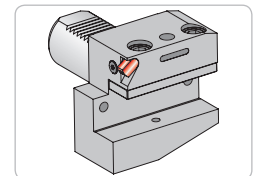
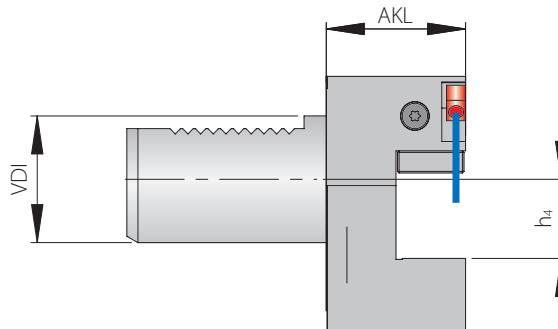
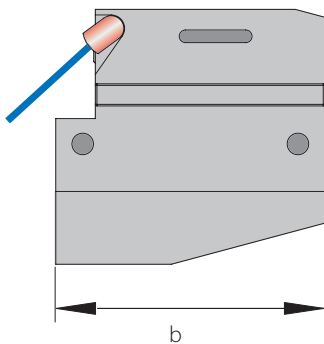

**Grundhalter / Basic holder / Adattatore**

Bezeichnung Designation Articolo	VDI	h4	AKL	b	Kühlmitteldüse Coolant jet Ugello refrigerante	Schraube für Kühlmitteldüse Screw for coolant jet Vite per ugello refrigerante
KMH01-B2-25X16X30	25	16	30	55	KMD0519	AS0020
KMH01-B2-30X20X40	30	20	40	70	KMD0830	AS0020
KMH01-B2-40X25X44	40	25	44	85	KMD0830	AS0020
KMH01-B2-40X25X70	40	25	70	85	KMD0830	AS0020

**Form B3 – Überkopf – kurz / Form B3 – Overhead – short /**  
Forma B3 – Invertito – corta

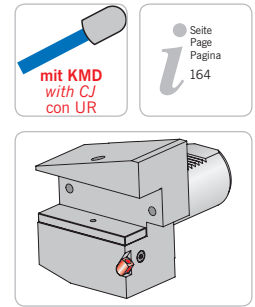
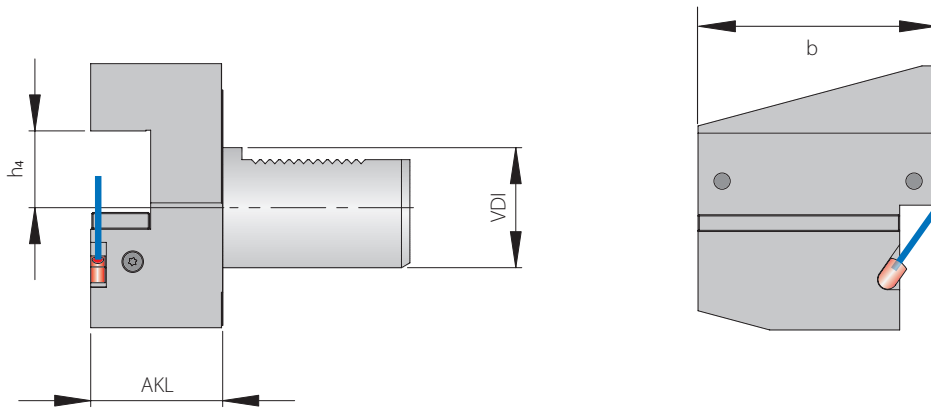

**Grundhalter / Basic holder / Adattatore**

Bezeichnung Designation Articolo	VDI	h4	AKL	b	Kühlmitteldüse Coolant jet Ugello refrigerante	Schraube für Kühlmitteldüse Screw for coolant jet Vite per ugello refrigerante
KMH01-B3-16X12X24	16	12	24	42	KMD0519	AS0020
KMH01-B3-20X16X30	20	16	30	55	KMD0519	AS0020
KMH01-B3-25X16X30	25	16	30	55	KMD0519	AS0020
KMH01-B3-30X20X40	30	20	40	70	KMD0830	AS0020
KMH01-B3-40X25X44	40	25	44	85	KMD0830	AS0020
KMH01-B3-50X32X55	50	32	55	100	KMD0830	AS0020

**Form B4 – Überkopf – kurz / Form B4 – Overhead – short /**  
Forma B4 – Invertito – corta

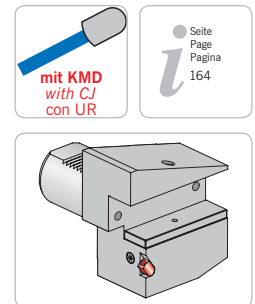
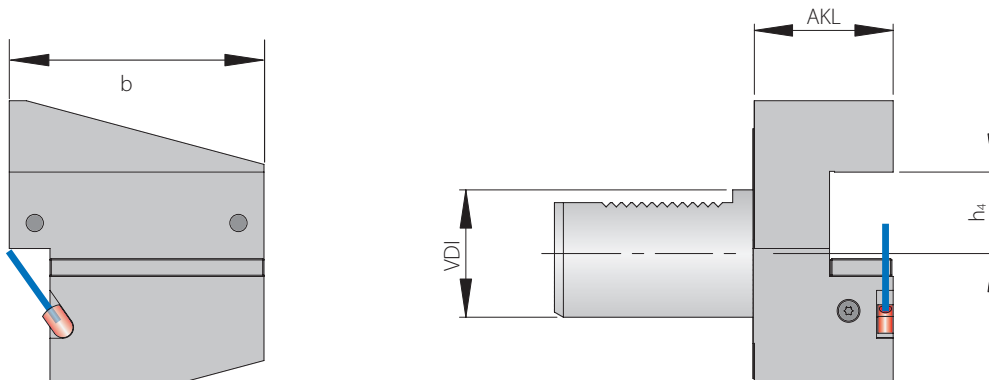

**Grundhalter / Basic holder / Adattatore**

Bezeichnung Designation Articolo	VDI	h4	AKL	b	Kühlmitteldüse Coolant jet Ugello refrigerante	Schraube für Kühlmitteldüse Screw for coolant jet Vite per ugello refrigerante
KMH01-B4-16X12X24	16	12	24	42	KMD0519	AS0020
KMH01-B4-20X16X30	20	16	30	55	KMD0519	AS0020
KMH01-B4-25X16X30	25	16	30	55	KMD0519	AS0020
KMH01-B4-30X20X40	30	20	40	70	KMD0830	AS0020
KMH01-B4-40X25X44	40	25	44	85	KMD0830	AS0020
KMH01-B4-50X32X55	50	32	55	100	KMD0830	AS0020

**Form B5 – lang / Form B5 – long / Forma B5 – lunga**

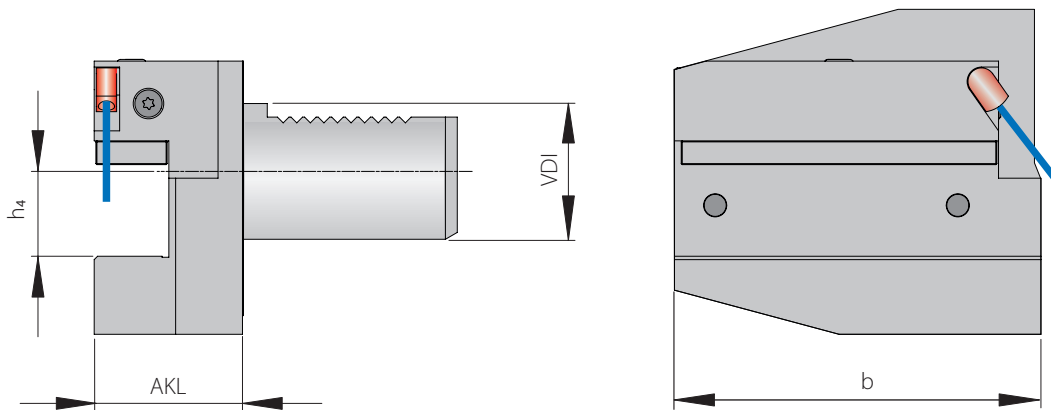
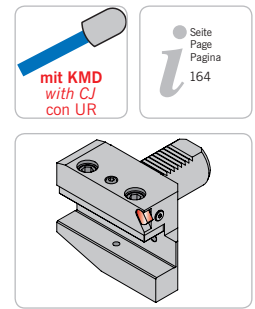

**Grundhalter / Basic holder / Adattatore**

Bezeichnung Designation Articolo	VDI	h4	AKL	b	Kühlmitteldüse Coolant jet Ugello refrigerante	Schraube für Kühlmitteldüse Screw for coolant jet Vite per ugello refrigerante
KMH01-B5-40X25X44	40	25	44	108	KMD0830	AS0020

2

**Form B6 – lang / Form B6 – long / Forma B6 – lunga**

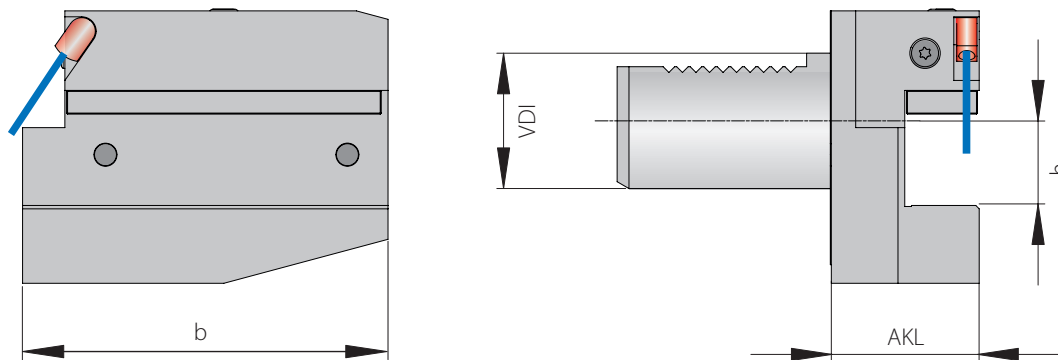
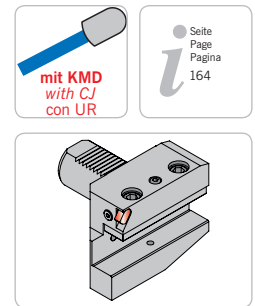

**Grundhalter / Basic holder / Adattatore**

Bezeichnung Designation Articolo	VDI	h4	AKL	b	Kühlmitteldüse Coolant jet Ugello refrigerante	Schraube für Kühlmitteldüse Screw for coolant jet Vite per ugello refrigerante
KMH01-B6-40X25X44	40	25	44	108	KMD0830	AS0020

**Form B7 – Überkopf – lang / Form B7 – Overhead – long /**  
Forma B7 – Invertito – lunga

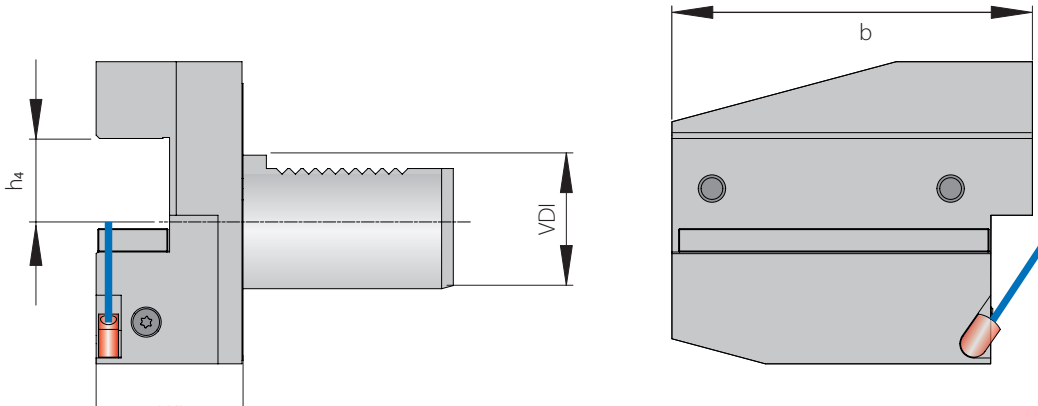
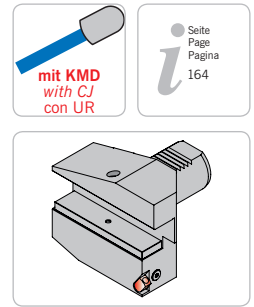

**Grundhalter / Basic holder / Adattatore**

Bezeichnung Designation Articolo	VDI	h4	AKL	b	Kühlmitteldüse Coolant jet Ugello refrigerante	Schraube für Kühlmitteldüse Screw for coolant jet Vite per ugello refrigerante
KMH01-B7-40X25X44	40	25	44	108	KMD0830	AS0020



**Form C1 / Form C1 / Forma C1**

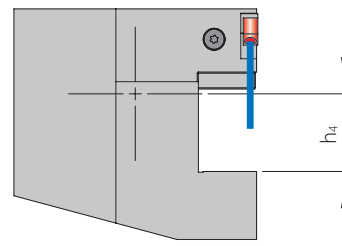
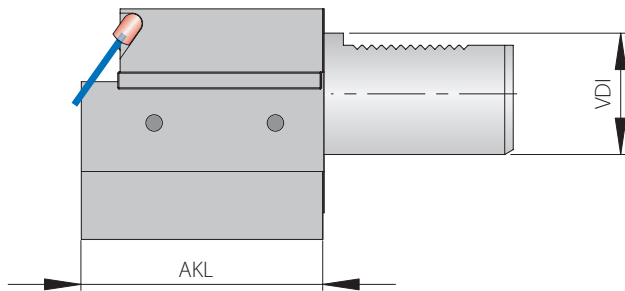
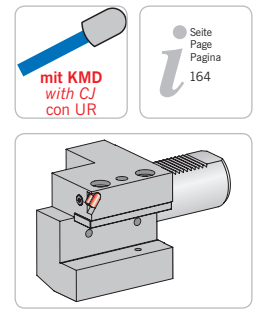

**Grundhalter / Basic holder / Adattatore**

Bezeichnung Designation Articolo	VDI	h4	AKL	Kühlmitteldüse Coolant jet Ugello refrigerante	Schraube für Kühlmitteldüse Screw for coolant jet Vite per ugello refrigerante
KMH01-C1-25X16	25	55	16	KMD0519	AS0020
KMH01-C1-25X20	25	55	20	KMD0519	AS0020
KMH01-C1-30X20	30	70	20	KMD0519	AS0020
KMH01-C1-40X25	40	85	25	KMD0519	AS0020
KMH01-C1-50X32	50	100	32	KMD0519	AS0020

**Form C2 / Form C2 / Forma C2**

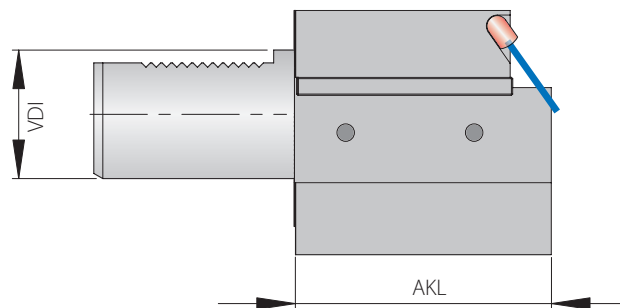
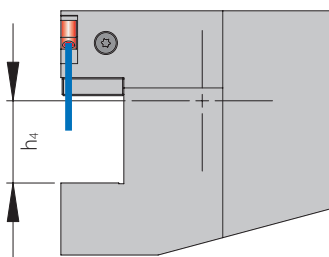
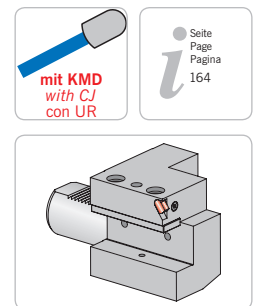

**Grundhalter / Basic holder / Adattatore**

Bezeichnung Designation Articolo	VDI	h4	AKL	Kühlmitteldüse Coolant jet Ugello refrigerante	Schraube für Kühlmitteldüse Screw for coolant jet Vite per ugello refrigerante
KMH01-C2-16X12	16	44	12	KMD0519	AS0020
KMH01-C2-20X16	20	50	16	KMD0519	AS0020
KMH01-C2-30X20	30	70	20	KMD0519	AS0020
KMH01-C2-40X25	40	85	25	KMD0519	AS0020
KMH01-C2-50X32	50	100	32	KMD0519	AS0020

**Form C3 – Überkopf / Form C3 – Overhead / Forma C3 – Invertito**

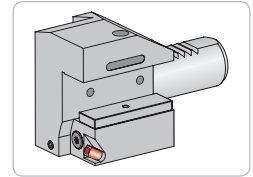
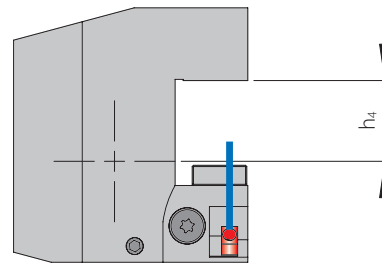
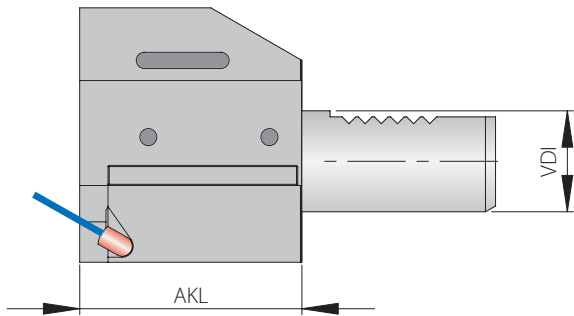

**Grundhalter / Basic holder / Adattatore**

Bezeichnung Designation Articolo	VDI	h4	AKL	Kühlmitteldüse Coolant jet Ugello refrigerante	Schraube für Kühlmitteldüse Screw for coolant jet Vite per ugello refrigerante
KMH01-C3-16X12	16	44	12	KMD0519	AS0020
KMH01-C3-20X16	20	50	16	KMD0519	AS0020
KMH01-C3-30X20	30	70	20	KMD0519	AS0020
KMH01-C3-40X25	40	85	25	KMD0519	AS0020
KMH01-C3-50X32	50	100	32	KMD0519	AS0020

2

**Form C4 – Überkopf / Form C4 – Overhead / Forma C4 – Invertito**

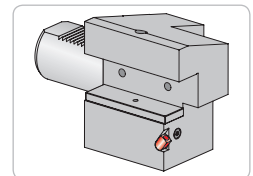
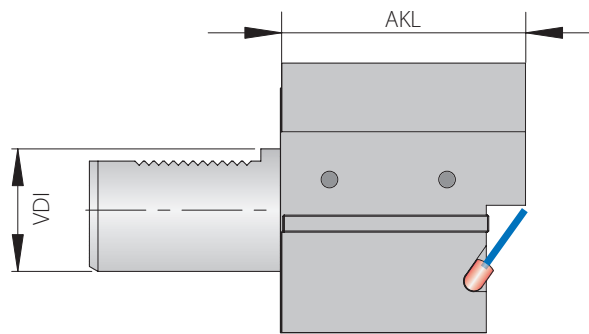
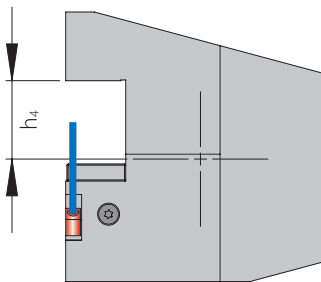

**Grundhalter / Basic holder / Adattatore**

Bezeichnung Designation Articolo	VDI	h4	AKL	Kühlmitteldüse Coolant jet Ugello refrigerante	Schraube für Kühlmitteldüse Screw for coolant jet Vite per ugello refrigerante
KMH01-C4-16X12	16	44	12	KMD0519	AS0020
KMH01-C4-20X16	20	50	16	KMD0519	AS0020
KMH01-C4-25X16	25	55	16	KMD0519	AS0020
KMH01-C4-25X20	25	55	20	KMD0519	AS0020
KMH01-C4-30X20	30	70	20	KMD0519	AS0020
KMH01-C4-40X25	40	85	25	KMD0519	AS0020
KMH01-C4-50X32	50	100	32	KMD0519	AS0020

**Standardausführung**

- präzisionsgeschliffener Schneideinsatz
- zweiseitig
- spezielle Geometrie zur Spaneinschnürung
- zum Einstechen bei kleinen bis mittleren Spanquerschnitten
- geringe Schnittkräfte durch scharfe Schneidkante
- für eine Vielzahl von Werkstückstoffen
- für Innen- und Außenbearbeitung

**Standard geometry**

- *precision ground insert*
- *two cutting edges*
- *special geometry with chip-contraction*
- *for grooving with small to medium chip-cross-section*
- *low cutting forces because of sharp cutting edges*
- *for a number of workpiece materials*
- *for internal and external machining*

**Esecuzione standard**

- inserto rettificato di precisione
- 2 taglienti
- geometria speciale adatta alla contrazione del truciolo
- per una scanalatura di sezioni di truciolo piccole e medie
- taglio dolce per il tagliente affilato
- adatto ad un vasto numero di materiali
- uso interno ed esterno

**Kopierausführung -12**

- präzisionsgeschliffener Schneideinsatz
- zweiseitig
- spezielle Geometrie zur Spaneinschnürung
- mit 12° positivem Spanwinkel an allen drei Hauptschneiden
- Anwendung entspricht der Standardausführung, jedoch zusätzlich zum Kopierdrehen bei mittleren Spanquerschnitten
- für Innen- und Außenbearbeitung

**Geometry for copying -12**

- *precision ground insert*
- *two cutting edges*
- *special geometry for chip-contraction*
- *12° positive rake angle on all three cutting edges*
- *same application as standard execution, but also for copy-turning with medium chip-cross-section*
- *for internal and external machining*

**Geometria di copiatura -12**

- inserto rettificato di precisione
- 2 taglienti
- geometria speciale adatta alla contrazione del truciolo
- angolo di taglio a 12° positivo, tri-direzionale
- medesima applicazione dell'esecuzione standard, ma adatto alla tornitura di sezioni di truciolo piccole e medie
- uso interno ed esterno

**AM-Geometrie**

- präzisionsgesinterter 2-seitiger Schneideinsatz
- Schneideinsatz zum Stechdrehen, Ein- und Abstechen
- hohe Zerspanungsleistung durch stabile Schneidkante
- geringe Schnittkräfte durch positive Schneidengeometrie
- für Innen- und Außenbearbeitung

**AM geometry**

- *precision sintered twin edge inserts*
- *inserts for groove turning, cut in and withdraw*
- *considerable chip removal via stable cutting edge*
- *minimum cutting force via positive cutting geometry*
- *for internal and external machining*

**Geometria AM**

- inserto sinterizzato a 2 tagli
- inserto per tornitura di scanalatura
- considerevole volume di truciolo grazie alla stabilità del tagliente
- taglio dolce per la geometria di taglio positiva
- uso interno ed esterno

**Vollradiusausführung V**

- präzisionsgeschliffener Schneideinsatz
- zweiseitig
- Vollradius
- für Einstiche und Nachkopieroperationen bei kleinen Spanquerschnitten
- Zerspanung kurzspanender Werkstoffe
- für Innen- und Außenbearbeitung

**Full radius execution V**

- *precision ground insert*
- *two cutting edges*
- *full radius*
- *for grooving and copy-turning operations with small chip-cross-section*
- *machining of short chipping materials*
- *for internal and external machining*

**Esecuzione a raggio completo V**

- inserto rettificato di precisione
- 2 taglienti
- raggio completo
- per scanalatura e copiatura di ridotte sezioni di taglio
- lavorazione di materiali a truciolo corto
- uso interno ed esterno





### Vollradiusausführung VK

- präzisionsgeschliffener Schneideinsatz
- zweiseitig, Vollradius
- für Einstiche und Nachkopieroperationen bei entsprechenden Konturen bis mittlere Spanquerschnitte

#### Besonderheit:

- spezielle Spanformgeometrie für kontrollierten Spanbruch auch bei langspanenden Werkstoffen
- für Innen- und Außenbearbeitung

### Full radius execution VK

- precision ground insert
- two cutting edges, full radius
- for grooving and copy-turning operations up to medium chip-cross-section

#### Particularity:

- special chipbreaker for controlled-chipbreaking when machining long chipping materials
- for internal and external machining

### Esecuzione a raggio completo VK

- inserto rettificato di precisione
- 2 taglienti, raggio completo
- per scanalatura e copiatura di sezioni di truciolo medie

#### Particolarità:

- geometria adatta al controllo del truciolo di materiali a truciolo lungo
- uso interno ed esterno



### Aluminiumausführung -ALU

- präzisionsgeschliffener Schneideinsatz
- zweiseitig
- spezielle Geometrie zur Spaneinschnürung
- mit 25° positivem Spanwinkel an allen drei Hauptschneiden
- für Einstich- und Kopierarbeiten bei NE-Metallen und Kunststoff
- für Innen- und Außenbearbeitung

### Aluminium type -ALU

- precision ground insert
- two cutting edges
- special geometry for chip-contraction
- 25° positive rake angle on all three cutting edges
- grooving and copy-turning of non-ferrous materials and plastics
- for internal and external machining

### Geometria -ALU

- inserto rettificato di precisione
- 2 taglienti
- geometria adatta specificamente alla contrazione del truciolo
- angolo di taglio a 25° positivo, tri-direzionale
- per scanalatura e copiatura di materiali non ferrosi e plastici
- uso interno ed esterno



### Ausführung für Sicherungsringeinstiche

- präzisionsgeschliffener Schneideinsatz
- zweiseitig
- für alle Einstiche nach DIN 471/472 unter Verwendung von nur einer Unterstützplatte
- für Innen- und Außenbearbeitung

### Circlip grooves execution

- precision ground insert
- two cutting edges
- for all grooves to DIN 471/472 by using only one support blade for all widths
- for internal and external machining

### Esecuzioni per canali

- inserto rettificato di precisione
- 2 taglienti
- per gole secondo norma DIN 471/472 usando una sola lama per tutti gli spessori
- uso interno ed esterno

## Beschichtet / Coated / Rivestito

### AM27C

#### CVD-Mehrlagenbeschichtung

Bearbeitung von Stahl, Stahlguss mit mittleren bis hohen Schnittgeschwindigkeiten, mittleren bis großen Spanquerschnitten und wechselnden Schnitttiefen. Speziell einsetzbar für Stähle mit starker Verklebneigung. Einsatz im Schlicht- und mittleren Schruppbereich.

#### CVD-multilayer coating

*Machining steel, cast steel as well as grey cast iron, at medium to high cutting speeds, medium to large chip-cross-sections and varying depths of cut. Used for finishing and medium roughing.*

#### Rivestimento multistrato CVD

Lavorazione di acciaio, acciaio da fusione con velocità di taglio da medie ad elevate, sezioni di truciolo medie e larghe e profondità di taglio varie. Per finitura e media sgrassatura.

### AM35C

#### CVD-Mehrlagenbeschichtung

Bearbeitung von Stahl, rostfreiem Stahl sowie Stahlguss bei mittleren bis großen Spanquerschnitten und mittleren bis geringen Schnittgeschwindigkeiten unter ungünstigen Bearbeitungsbedingungen und hohen Zähigkeitsanforderungen.

#### CVD-multilayer coating

*Machining steel, stainless steel and cast steel, at medium to large chip-cross-sections and medium to low cutting speeds under unfavourable machining conditions where good toughness is required.*

#### Rivestimento multistrato CVD

Lavorazione di acciaio inossidabile e acciaio da fusione per sezioni di taglio medie e grandi e velocità di taglio medie e basse. In condizioni di lavorazione non favorevoli quando è richiesta una buona tenacità.

### AM350

#### CVD-Mehrlagenbeschichtung

Zur Bearbeitung von Stahl und Stahlguss mit hohen Schnittgeschwindigkeiten, mittleren bis hohen Spanquerschnitten und wechselnden Schnitttiefen. Verschleißfeste Sorte durch speziell aufeinander abgestimmtes Substrat und Beschichtung. Einsatz im Schlicht- und mittleren Schruppbereich.

#### CVD-multilayer coating

*Grade with a good combination of wear resistance and toughness for turning steel, stainless steel as well as cast steel at medium chip-cross-sections and medium to high cutting speeds. Can also be used under unfavourable machining conditions. Special grade for stainless steel (austenitic). Apply in finishing and medium roughing applications.*

#### Rivestimento multistrato CVD

Grado resistente all'usura, buona tenacità per la tornitura dell'acciaio, acciaio inossidabile, sezioni di taglio medie, velocità di taglio medie ed elevate, in condizioni di lavoro non favorevoli. Grado particolarmente adatto a acciai austenitici ed acciai inossidabili.

### AM5035

#### PVD-Mehrlagenbeschichtung

Eine verbesserte PVD-Beschichtung auf einem zähen und verschleißfesten Hartmetallsubstrat. Mit einem höheren Kobaltgehalt verfügt diese Sorte über die nötige Zähigkeit, um den Ansprüchen beim Ein- und Abstechen gerecht zu werden. AM5035 ist ausgezeichnet für die Bearbeitung der meisten Stähle, nichtrostenden Stählen und schwer zerspanbaren Stählen.

#### PVD-multilayer coating

*An improved PVD coating on a tough and wear resistant carbide grade. Due to the higher cobalt content this grade contains all the required toughness for part-off and grooving applications. AM5035 is excellent at machining most steel, stainless steel and hard to machine materials.*

#### Rivestimento multiplo PVD

Un rivestimento PVD di ultima generazione, su base di metallo duro resistente all'usura e con una buona tenacità. Grazie all'elevato contenuto di cobalto, questa qualità ha la tenacità necessaria per la lavorazione di gole e per la tronatura. La qualità AM5035 è indicata per la lavorazione della maggior parte degli acciai, dell'acciaio inossidabile, della ghisa e di materiali difficili da lavorare.

### AR17C

#### CVD-Mehrlagenbeschichtung

Bearbeitung von Grauguss, Gusseisen mit Kugelgraphit und Hartguss. Auch geeignet für rostfreien Stahl, Stahl und Stahlguss bei mittleren bis höchsten Schnittgeschwindigkeiten. Einsatz im Schlicht- und unteren Schruppbereich.

#### CVD-multilayer coating

*For machining grey cast iron, cast iron with graphite and hard cast material. Also suitable for stainless steel, steel and cast steel at medium to high cutting speed. Apply in finishing and lighter roughing applications.*

#### Rivestimento multistrato CVD

Lavorazione della ghisa, ghisa sferoidale, ghisa temperata, acciaio, fusioni d'acciaio a velocità di taglio medie, elevate e molto elevate; per finitura e tagli medi.

### AR27C

#### CVD-Mehrlagenbeschichtung

Bearbeitung von Stahl, Stahlguss, rostfreiem Stahl, Gusseisen mit Kugelgraphit sowie Grauguss mit hohen Schnittgeschwindigkeiten unter stabilen Bearbeitungsbedingungen.

#### CVD-multilayer coating

*Machining of steel, stainless steel, spheroidal cast iron, cast steel and grey cast iron at high cutting speeds under stable machining conditions.*

#### Rivestimento multistrato CVD

Lavorazione dell'acciaio, acciaio inossidabile, ghisa sferoidale, fusioni d'acciaio a velocità di taglio elevate in condizioni di taglio stabili.

## Beschichtet / Coated / Rivestito

### AT10

#### PVD-Mehrlagenbeschichtung

Zur Bearbeitung von Aluminium und Aluminiumlegierungen, Kupfer, Bronze, NE-Metallen und hochschmelzenden Werkstoffen bei mittleren Spanquerschnitten und unter ungünstigen Bearbeitungsbedingungen. Auch geeignet für rostfreie Stähle.

#### PVD-multilayer coating

Grade for machining aluminium and aluminium-alloy, copper, brass, non-ferrous materials and refractory metals at medium cutting and under unfavourable cutting conditions. Also suitable for stainless steel.

#### Rivestimento multistrato PVD

Per lavorare l'alluminio e sue leghe, il rame, il bronzo, materiali non ferrosi, e metalli refrattari (per esempio Niobio, Tantalio, Molibdeno, Wolframio) per sezioni di taglio medie e in condizioni di taglio non favorevoli.

## Unbeschichtet / Uncoated / Non rivestito

### AK10

Feinkorn-Hartmetall zur Bearbeitung von Gusswerkstoffen, Leicht- und Buntmetallen, hochschmelzenden Metallen und gehärteten Stählen bis 55 HRC. In Verbindung mit der Spanleitstufengeometrie-ALU besonders für das Stechdrehen von Al und Cu-Legierungen zu empfehlen.

Submicron carbide grade for machining cast materials, light and non-ferrous materials, refractory metals, hardened steels up to 55 HRC. In connection with chipbreaker-ALU specially suitable for machining Al- and Cu-alloys.

Metallo duro submicrograna per la lavorazione di fusioni, leghe leggere e non ferrose, metalli refrattari, metalli temprati fino a 55 HRC. Abbinato al rompitrucciolo-ALU è specificamente adatto per la lavorazione leghe di alluminio e rame.

### CERMET

Bearbeitung von Stahl, Stählen mittlerer Festigkeit sowie rostfreiem Stahl und Gusseisen mit Kugelgraphit. Bedingt einsetzbar für Grauguss.

Machining of steel, steels with medium tensile strength as well as stainless steel and spheroidal cast iron. Limited use on grey cast iron.

Lavorazione dell'acciaio, acciai di durezza media come l'acciaio inossidabile e la ghisa sferoidale. Uso limitato sulla ghisa grigia.

### AH7520 (CBN)

Bearbeitung von gehärteten Werkstoffen (sekundärharte Eisenwerkstoffe). Z. B.: Hartguss, gehärtete Stähle ab 50 HRC, Nihard und Stellite.

Machining of hardened materials (hardened steels). For example, hard cast iron, hardened steel from 50 HRC onwards, Nihard and stellite.

Lavorazione di materiali duri (acciai temprati). P.e. : ghisa temprata, acciaio temprato > 50 HRC, Nihard e stellite.

### AN8020 (PKD)

Bearbeitung von NE-Metallen, Aluminiumlegierungen mit Siliziumanteilen, glas- und kohlefaserverstärkte Kunststoffe, Kugelgraphitguss bei hohen Schnittdaten. Durch die scharfe Schneidkante entstehen geringe Schnittdrücke und sehr gute Oberflächengüten bei extrem hoher Wärmeleitfähigkeit. Fein- und Feinstbearbeitung bei glattem und unterbrochenem Schnitt.

Machining of non-ferrous metals, aluminium alloys with silicon, glass- and coal-fiber reinforced materials, spheroidal cast iron, at high cutting speeds. Sharp cutting edges enable low cutting forces and extremely good surface finish. Finishing and super finishing even at interrupted cuts.

Lavorazione dei metalli non ferrosi, leghe d'alluminio con basso tenore di Silicio, materiali rinforzati al vetro e fibre di carbonio, a velocità di taglio elevate. Il tagliente affilato rende possibile bassi sforzi di taglio ed una finitura superficiale estremamente buona. Finitura e super finitura anche con taglio interrotto.

NC-Standard

Standardausführung / Standard geometry / Esecuzione standard

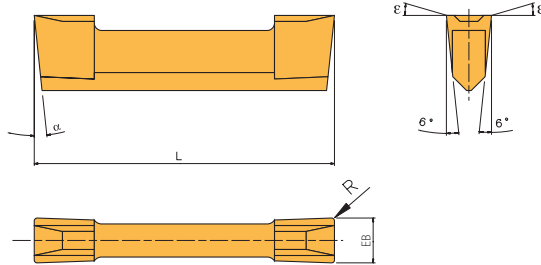

Bezeichnung Designation Articolo	EB ± 0,02	L ± 0,02	α	R	ε	Anwendung Application Applicazione	Sorten / Grades / Gradi											
							beschichtet/ coated/rivestito					unbeschichtet uncoated non rivestito		hochhart ultra-hard extra duri				
							AM27C	AM35C	AM350	AM5035	AR17C	AR27C	AT10	AK10	CERMET	AH7520	AN8020	
21201	2,0	12,0	7/15°	0,1	12°	Außen und Innen External and internal Esterno ed interno	●	●	●	●	●			●			●	
21201FN	2,0	12,0	7/15°	0,1	0°													●
21201TN	2,0	12,0	7/15°	0,1	0°													●
21204	2,0	12,0	7/15°	0,4	12°			●		●								
31602	3,0	16,0	7/15°	0,2	12°			●	●	●	●	●			●			●
31602FN	3,0	16,0	7/15°	0,2	0°													●
31602TN	3,0	16,0	7/15°	0,2	0°													●
31604	3,0	16,0	7/15°	0,4	12°			●		●								
32002	3,0	20,0	6/16°	0,2	12°			●	●	●	●	●			●			●
32002FN	3,0	20,0	6/16°	0,2	0°													●
32002TN	3,0	20,0	6/16°	0,2	0°													●
32004	3,0	20,0	6/16°	0,4	12°			●		●								
42202	4,0	22,0	6/9,5°	0,2	12°			●	●	●	●	●			●			●
42202FN	4,0	22,0	6/9,5°	0,2	0°													●
42202TN	4,0	22,0	6/9,5°	0,2	0°													●
42204	4,0	22,0	6/9,5°	0,4	12°			●		●								
42210	4,0	22,0	6/9,5°	1,0	12°			●										
52502	5,0	25,0	6/8,5°	0,2	12°			●	●	●	●	●			●			●
52502FN	5,0	25,0	6/8,5°	0,2	0°													●
52502TN	5,0	25,0	6/8,5°	0,2	0°													●
52504	5,0	25,0	6/8,5°	0,4	12°		●		●									
63002	6,0	30,0	6°	0,2	12°		●	●	●	●	●			●			●	
63002FN	6,0	30,0	6°	0,2	0°												●	
63002TN	6,0	30,0	6°	0,2	0°												●	
63004	6,0	30,0	6°	0,4	12°		●		●									
63010	6,0	30,0	6°	1,0	12°		●											
83804	8,0	38,0	6°	0,4	12°		●	●	●	●				●			●	
83804FN	8,0	38,0	6°	0,4	0°												●	
83804TN	8,0	38,0	6°	0,4	0°												●	
104604	10,0	46,0	6°	0,4	12°		●	●	●	●				●			●	
104604FN	10,0	46,0	6°	0,4	0°												●	
104604TN	10,0	46,0	6°	0,4	0°												●	
						Nur Außen External only Solo esterno												

Hinweis für AN8020 und AH7520: Einseitig bestückte Schneideinsätze mit einem Spanwinkel von 0°  
Remark for AN8020 and AH7520 inserts: single-sided with a rake angle of 0°  
Nota gli inserti AN8020 e AH7520 hanno un solo tagliente con un angolo di taglio di 0°

ε = Spanwinkel  
Rake angle  
Angolo di taglio

● Hauptanwendung  
Main application  
Applicazione principale  
○ Nebenanwendung  
Secondary application  
Applicazione secondaria

P	●	○	○	○	○												
M	○	●	●	○	○												
K						●	●							●			
N														●			●
S	○	○	○		○								○				
H					○												●



NC-12

Kopierausführung / Geometry for copying / Geometria di copiatura

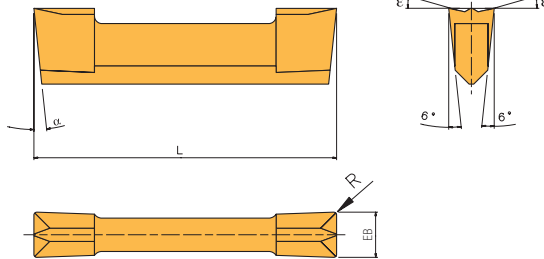

geschliffen  
ground  
rettificato

2

Bezeichnung Designation Articolo	EB ± 0,02	L ± 0,02	α	R	ε	Anwendung Application Applicazione	Sorten / Grades / Gradi											
							beschichtet/ coated/rivestito						unbeschichtet uncoated non rivestito		hochhart ultra-hard extra duri			
							AM27C	AM35C	AM350	AM5035	AR17C	AR27C	AT10	AK10	CERMET	AH7520	AN8020	
21201-12	2,0	12,0	7/15°	0,1	12°	Außen und Innen External and internal Esterno ed interno	●	●	●						●			
21202-12	1,9	11,9	7/15°	0,2	12°											●		
31602-12	3,0	16,0	7/15°	0,2	12°		●	●		●						●		
31604-12	2,9	15,6	7/15°	0,4	12°											●		
32002-12	3,0	20,0	6/16°	0,2	12°		●	●		●						●		
32004-12	2,9	19,7	6/16°	0,4	12°											●		
42202-12	4,0	22,0	6/9,5°	0,2	12°		●	●		●						●		
42204-12	3,9	21,7	6/9,5°	0,4	12°											●		
52502-12	5,0	25,0	6/8,5°	0,2	12°		●	●		●						●		
52504-12	4,9	24,6	6/8,5°	0,4	12°											●		
63002-12	6,0	30,0	6°	0,2	12°	●	●		●									
83804-12	8,0	38,0	6°	0,4	12°	Nur Außen External only Solo esterno		●										
104604-12	10,0	46,0	6°	0,4	12°		●											

ε = Spanwinkel  
Rake angle  
Angolo di taglio

- Hauptanwendung  
Main application  
Applicazione principale
- Nebenanwendung  
Secondary application  
Applicazione secondaria

	P	M	K	N	S	H
● Hauptanwendung	●	●	○			
○ Nebenanwendung	○	○	●			
				○		
	○	○	○			

NC-AM

Kopierausführung / Geometry for copying / Geometria di copiatura

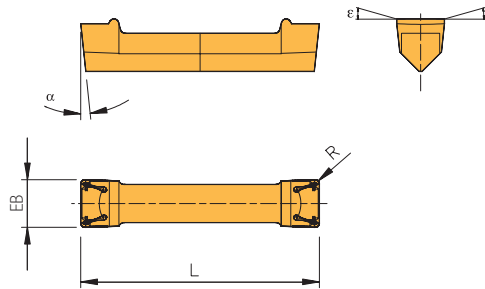

gesintert  
sintered  
sinterizzato

Bezeichnung Designation Articolo	EB ± 0,05	L	α	R	ε	Anwendung Application Applicazione	Sorten / Grades / Gradi											
							beschichtet/ coated/rivestito						unbeschichtet uncoated non rivestito		hochhart ultra-hard extra duri			
							AM27C	AM35C	AM350	AM5035	AR17C	AR27C	AT10	AK10	CERMET	AH7520	AN8020	
21202-AM	2,06	12,0	6/15°	0,2	6°/20°	Außen und Innen External and internal Esterno ed interno	●	●										
31602-AM	3,06	16,0	6/15°	0,2	6°/20°		●	●										
32002-AM	3,06	20,0	6/15°	0,2	6°/20°		●	●										
42204-AM	4,06	22,0	6/9,5°	0,4	6°/20°		●	●										
52504-AM	5,06	25,0	6/8,5°	0,4	6°/20°		●	●										
63008-AM	6,06	30,0	6°	0,8	6°/20°	●	●											
83808-AM	8,06	38,0	6°	0,8	6°/20°	Nur Außen External only Solo esterno	●	●										
104608-AM	10,07	46,0	6°	0,8	6°/20°		●	●										

ε = Spanwinkel  
Rake angle  
Angolo di taglio

- Hauptanwendung  
Main application  
Applicazione principale
- Nebenanwendung  
Secondary application  
Applicazione secondaria

	P	M	K	N	S	H
AM27C	●	○				
AM35C	○	●				
AM350						
AM5035						
AR17C						
AR27C						
AT10						
AK10						
CERMET						
AH7520						
AN8020						

2

NC-V

Vollradiusausführung / Full radius execution / Esecuzione a raggio completo

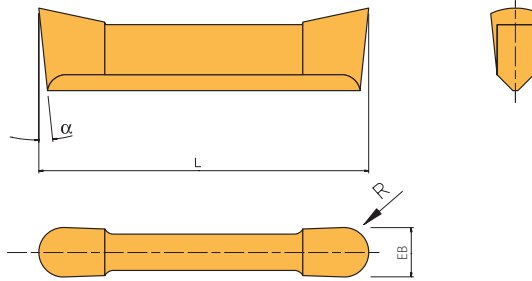

2

Bezeichnung Designation Articolo	EB ± 0,02	L ± 0,02	α	R	ε	Anwendung Application Applicazione	Sorten / Grades / Gradi											
							beschichtet/ coated/ripestito					unbeschichtet uncoated non rivestito		hochhart ultra-hard extra duri				
							AM27C	AM35C	AM350	AM5035	AR17C	AR27C	AT10	AK10	CERMET	AH7520	AN8020	
21210V	2,0	12,0	7/15°	1,0	12°	Außen und Innen External and internal Esterno ed interno		●						●			●	
21210V-FN	2,0	12,0	7/15°	1,0	0°													●
21210V-TN	2,0	12,0	7/15°	1,0	0°													●
31615V	3,0	16,0	7/15°	1,5	12°			●							●			●
31615V-FN	3,0	16,0	7/15°	1,5	0°													●
31615V-TN	3,0	16,0	7/15°	1,5	0°													●
32015V	3,0	20,0	6/16°	1,5	10°			●							●			●
32015V-FN	3,0	20,0	6/16°	1,5	0°													●
32015V-TN	3,0	20,0	6/16°	1,5	0°													●
42220V	4,0	22,0	6/9,5°	2,0	10°			●							●			●
42220V-FN	4,0	22,0	6/9,5°	2,0	0°													●
42220V-TN	4,0	22,0	6/9,5°	2,0	0°													●
52525V	5,0	25,0	6/8,5°	2,5	10°			●							●			●
52525V-FN	5,0	25,0	6/8,5°	2,5	0°													●
52525V-TN	5,0	25,0	6/8,5°	2,5	0°													●
63030V	6,0	30,0	6°	3,0	10°		●							●			●	
63030V-FN	6,0	30,0	6°	3,0	0°												●	
63030V-TN	6,0	30,0	6°	3,0	0°												●	
83840V	8,0	38,0	6°	4,0	10°		●							●			●	
83840V-FN	8,0	38,0	6°	4,0	0°												●	
83840V-TN	8,0	38,0	6°	4,0	0°												●	
104650V	10,0	46,0	6°	5,0	10°		●							●			●	
104650V-FN	10,0	46,0	6°	5,0	0°												●	
104650V-TN	10,0	46,0	6°	5,0	0°												●	

Achtung: Beim Einsatz von Schneideinsätzen in Vollradiusausführung muss die Unterstutzplatte abgeändert werden.  
 Attention: The use of full radius inserts require a slightly modified support blade.  
 Attenzione: l'utilizzo degli inserti a raggio completo rende necessaria una modifica della lama.

Hinweis für AN8020 und AH7520: Einseitig bestückte Schneideinsätze mit einem Spanwinkel von 0°  
 Remark for AN8020 and AH7520 inserts: single-sided with a rank angle of 0°  
 Nota gli inserti AN8020 e AH7520 hanno un solo tagliente con un angolo di taglio di 0°

ε = Spanwinkel  
 Rake angle  
 Angolo di taglio

- Hauptanwendung  
Main application  
Applicazione principale
- Nebenanwendung  
Secondary application  
Applicazione secondaria

P	●		
M	○		
K		●	
N		●	●
S	○		
H			●

NC-VK

Vollradiusausführung / Full radius execution / Esecuzione a raggio completo

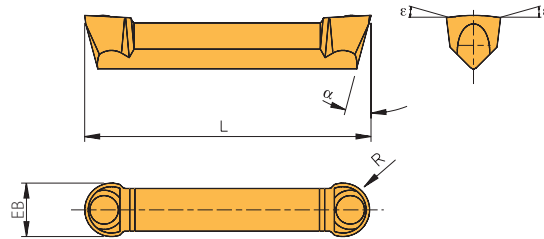

Bezeichnung Designation Articolo	EB ± 0,02	L ± 0,02	α	R	ε	Anwendung Application Applicazione	Sorten / Grades / Gradi											
							beschichtet/ coated/rivestito				unbeschichtet uncoated non rivestito		hochhart ultra-hard extra duri					
							AM27C	AM35C	AM350	AM5035	AR17C	AR27C	AT10	AK10	CERMET	AH7520	AN8020	
21210VK	2,0	12,0	7/15°	1,0	3°	Außen und Innen External and internal Esterno ed interno		●	●				●	●				
31615VK	3,0	16,0	7/15°	1,5	3°			●	●					●	●			
32015VK	3,0	20,0	6/16°	1,5	3°			●	●					●	●			
42220VK	4,0	22,0	6/9,5°	2,0	3°			●	●					●	●			
52525VK	5,0	25,0	6/8,5°	2,5	3°			●	●					●	●			
63030VK	6,0	30,0	6°	3,0	3°	Nur Außen External only Solo esterno		●	●				●	●				
83840VK	8,0	38,0	6°	4,0	3°			●	●					●	●			
104650VK	10,0	46,0	6°	5,0	3°			●	●					●	●			

Achtung: Beim Einsatz von Schneideinsätzen in Vollradiusausführung muss die Unterstutzplatte abgeändert werden.  
 Attention: The use of full radius inserts require a slightly modified support blade.  
 Attenzione: l'utilizzo degli inserti a raggio completo rende necessaria una modifica della lama.

ε = Spanwinkel  
 Rake angle  
 Angolo di taglio

● Hauptanwendung  
 Main application  
 Applicazione principale  
 ○ Nebenanwendung  
 Secondary application  
 Applicazione secondaria

	P	M	K	N	S	H
AM27C	●	○				
AM35C	○	●				
AM350			●			
AM5035				○		
AR17C				●		
AR27C				●		
AT10				○		
AK10					●	
CERMET					●	
AH7520						○
AN8020						○





NC-ALU

Aluminiumausführung / Aluminium geometry / Geometria alluminio

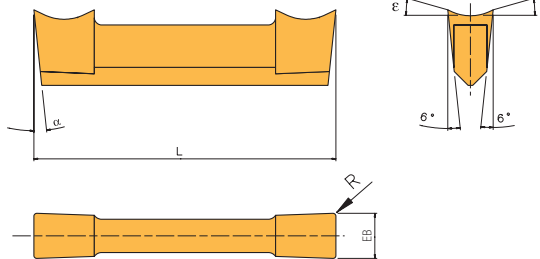

2

Bezeichnung Designation Articolo	EB ± 0,02	L ± 0,02	α	R	ε	Anwendung Application Applicazione	Sorten / Grades / Gradi											
							beschichtet/ coated/rivestito					unbeschichtet uncoated non rivestito		hochhart ultra-hard extra duri				
							AM27C	AM35C	AM350	AM5035	AR17C	AR27C	AT10	AK10	CERMET	AH7520	AN8020	
21201-ALU	2,0	12,0	8/15°	0,1	25°	Außen und Innen External and internal Esterno ed interno							●	●				
31602-ALU	3,0	16,0	8/15°	0,2	25°									●	●			
32002-ALU	3,0	20,0	8/16°	0,2	25°									●	●			
42202-ALU	4,0	22,0	8°	0,2	25°									●	●			
52502-ALU	5,0	25,0	8°	0,2	25°									●	●			
63002-ALU	6,0	30,0	8°	0,2	25°		●						●	●				
83804-ALU	8,0	38,0	8°	0,4	25°	Nur Außen External only Solo esterno							●	●				
104604-ALU	10,0	46,0	8°	0,4	25°									●	●			

ε = Spanwinkel  
Rake angle  
Angolo di taglio

- Hauptanwendung  
Main application  
Applicazione principale
- Nebenanwendung  
Secondary application  
Applicazione secondaria

	P	M	K	N	S	H
	●	○				
				○		
				●		
				●		
				○	○	

**NC-DIN471**

**Ausführung für Sicherungsringeinstiche / Circlip inserts /**  
Inserti per sedi seeger

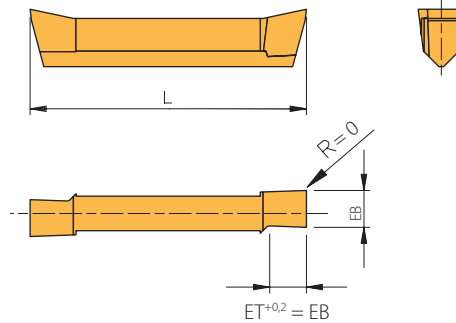

Rechte Ausführung abgebildet  
Right-hand execution shown  
Versione destra in figura

Bezeichnung Designation Articolo	EB ± 0,05	L ± 0,03	ε	Anwendung Application Applicazione	Sorten / Grades / Gradi											
					beschichtet/ coated/rivestito						unbeschichtet uncoated non rivestito		hochhart ultra-hard extra duri			
					AM27C	AM35C	AM350	AM5035	AR17C	AR27C	AT10	AK10	CERMET	AH7520	AN8020	
2-04/471 R/L	0,55	12,0	12°	Außen- und Innenbearbeitung  External and internal use  Per uso esterno ed interno		●						●				
2-06/471 R/L	0,75	12,0	12°			●							●			
2-07/471 R/L	0,85	12,0	12°			●							●			
2-08/471 R/L	0,95	12,0	12°			●							●			
2-10/471 R/L	1,15	12,0	12°			●							●			
2-12/471 R/L	1,35	12,0	12°			●							●			
2-15/471 R/L	1,65	12,0	12°			●							●			
2-175/471 R/L	1,90	12,0	12°			●							●			
3-04/471 R/L	0,55	20,0	12°			●							●			
3-06/471 R/L	0,75	20,0	12°			●							●			
3-07/471 R/L	0,85	20,0	12°			●							●			
3-08/471 R/L	0,95	20,0	12°			●							●			
3-10/471 R/L	1,15	20,0	12°			●							●			
3-12/471 R/L	1,35	20,0	12°			●							●			
3-15/471 R/L	1,65	20,0	12°			●							●			
3-175/471 R/L	1,90	20,0	12°			●							●			
3-20/471 R/L	2,20	20,0	12°			●							●			
3-25/471 R/L	2,70	20,0	12°			●							●			
3-30/471 R/L	3,13	20,0	12°			●							●			
3M-04/471 R/L	0,55	16,0	12°			●										
3M-06/471 R/L	0,75	16,0	12°			●										
3M-07/471 R/L	0,85	16,0	12°			●										
3M-08/471 R/L	0,95	16,0	12°			●										
3M-10/471 R/L	1,15	16,0	12°			●										
3M-12/471 R/L	1,35	16,0	12°			●										
3M-15/471 R/L	1,65	16,0	12°			●										
3M-175/471 R/L	1,90	16,0	12°			●										
3M-20/471 R/L	2,20	16,0	12°			●										
3M-25/471 R/L	2,70	16,0	12°			●										
3M-30/471 R/L	3,13	16,0	12°			●										

ε = Spanwinkel  
Rake angle  
Angolo di taglio

- **Hauptanwendung**  
Main application  
Applicazione principale
- **Nebenanwendung**  
Secondary application  
Applicazione secondaria

P	●			
M	○			
K		●		
N		●		
S	○		○	
H				

Artikel / Item / Articolo
<b>U-Platte / Support blade / Spina staffa</b>
10208 R/L
102-2530 R/L
102-3040 R/L
102-4050 R/L
102-5060 R/L
102-6075 R/L
102-75100 R/L
102-100150 R/L
102-150300 R/L
102-300500 R/L
10312 R/L
103-2530 R/L
103-3040 R/L
103-4050 R/L
103-5060 R/L
103-6075 R/L
103-75100 R/L
103-100150 R/L
103-150300 R/L
103-300500 R/L
20306 R/L
20310 R/L
203-5060 R/L
203-6075 R/L
203-75100 R/L
203-100150 R/L
203-150300 R/L
203-300500 R/L
203-500XX R/L
203S-5060 R/L Kontra
203S-6075 R/L Kontra
203S-75100 R/L Kontra
203S-100150 R/L Kontra
203S-150300 R/L Kontra
203S-300500 R/L Kontra
203S-500XX R/L Kontra
20408 R/L
20412 R/L
204-5060 R/L
204-6075 R/L
204-75100 R/L
204-100150 R/L
204-150300 R/L
204-300500 R/L
204-500XX R/L
204S-5060 R/L Kontra
204S-6075 R/L Kontra
204S-75100 R/L Kontra
204S-100150 R/L Kontra
204S-150300 R/L Kontra
204S-300500 R/L Kontra
204S-500XX R/L Kontra
20511 R/L
20515 R/L
205-5060 R/L
205-6075 R/L
205-75100 R/L
205-100150 R/L
205-150300 R/L
205-300500 R/L
205-500XX R/L
205S-5060 R/L Kontra
205S-6075 R/L Kontra
205S-75100 R/L Kontra
205S-100150 R/L Kontra
205S-150300 R/L Kontra
205S-300500 R/L Kontra
205S-500XX R/L Kontra
20620 R/L
206-5060 R/L
206-6075 R/L
206-75100 R/L
206-100150 R/L
206-150300 R/L
206-300500 R/L
206-500XX R/L
206S-5060 R/L Kontra
206S-6075 R/L Kontra

Artikel / Item / Articolo
<b>U-Platte / Support blade / Spina staffa</b>
206S-75100 R/L Kontra
206S-100150 R/L Kontra
206S-150300 R/L Kontra
206S-300500 R/L Kontra
206S-500XX R/L Kontra
30817 R/L
308-75100 R/L
308-100150 R/L
308-150300 R/L
308-300500 R/L
308-500XX R/L
308S-75100 R/L Kontra
308S-100150 R/L Kontra
308S-150300 R/L Kontra
308S-300500 R/L Kontra
308S-500XX R/L Kontra
31025 R/L
310-75100 R/L
310-100150 R/L
310-150300 R/L
310-300500 R/L
310-500XX R/L
310S-75100 R/L Kontra
310S-100150 R/L Kontra
310S-150300 R/L Kontra
310S-300500 R/L Kontra
310S-500XX R/L Kontra
9-20310 R/L
9-20412 R/L
9-20515 R/L
9-20620 R/L
9-UT 316 R/L
9-UT 419 R/L
9-UT 522 R/L
9-UT 627 R/L
UA2/471 R/L
UA3/471 R/L
UA471 R/L
UI 471 R/L
UT316 R/L
UT3-5060 R/L
UT3-6075 R/L
UT3-75100 R/L
UT3-100150 R/L
UT3-150300 R/L
UT3-300500 R/L
UT3-500XX R/L
UT3S-5060 R/L Kontra
UT3S-6075 R/L Kontra
UT3S-75100 R/L Kontra
UT3S-100150 R/L Kontra
UT3S-150300 R/L Kontra
UT3S-300500 R/L Kontra
UT3S-500XX R/L Kontra
UT419 R/L
UT4-5060 R/L
UT4-6075 R/L
UT4-75100 R/L
UT4-100150 R/L
UT4-150300 R/L
UT4-300500 R/L
UT4-500XX R/L
UT4S-5060 R/L Kontra
UT4S-6075 R/L Kontra
UT4S-75100 R/L Kontra
UT4S-100150 R/L Kontra
UT4S-150300 R/L Kontra
UT4S-300500 R/L Kontra
UT4S-500XX R/L Kontra
UT522 R/L
UT5-5060 R/L
UT5-6075 R/L
UT5-75100 R/L
UT5-100150 R/L
UT5-150300 R/L
UT5-300500 R/L
UT5-500XX R/L
UT5S-5060 R/L Kontra

Artikel / Item / Articolo
<b>U-Platte / Support blade / Spina staffa</b>
UT5S-6075 R/L Kontra
UT5S-75100 R/L Kontra
UT5S-100150 R/L Kontra
UT5S-150300 R/L Kontra
UT5S-300500 R/L Kontra
UT5S-500XX R/L Kontra
UT627 R/L
UT6-5060 R/L
UT6-6075 R/L
UT6-75100 R/L
UT6-100150 R/L
UT6-150300 R/L
UT6-300500 R/L
UT6-500XX R/L
UT6S-5060 R/L Kontra
UT6S-6075 R/L Kontra
UT6S-75100 R/L Kontra
UT6S-100150 R/L Kontra
UT6S-150300 R/L Kontra
UT6S-300500 R/L Kontra
UT6S-500XX R/L Kontra
UT832 R/L
UT8-75100 R/L
UT8-100150 R/L
UT8-150300 R/L
UT8-300500 R/L
UT8-500XX R/L
UT8S-75100 R/L Kontra
UT8S-100150 R/L Kontra
UT8S-150300 R/L Kontra
UT8S-300500 R/L Kontra
UT8S-500XX R/L Kontra
UT1040 R/L
UT10-75100 R/L
UT10-100150 R/L
UT10-150300 R/L
UT10-300500 R/L
UT10-500XX R/L
UT10S-75100 R/L Kontra
UT10S-100150 R/L Kontra
UT10S-150300 R/L Kontra
UT10S-300500 R/L Kontra
UT10S-500XX R/L Kontra

Artikel / Item / Articolo
<b>Klemme / Clamb / Staffa</b>
KA3 R/L
KA4 R/L
KA5 R/L
KA6 R/L
KA8 R/L
KA10 R/L
KAK8 R/L
KAK10 R/L
KAM2 R/L
KAM2 R/L Kontra
KAM3 R/L
KAM3 R/L Kontra
KAML3 R/L
KAS3 R/L Kontra
KAS4 R/L Kontra
KAS5 R/L Kontra
KAS6 R/L Kontra
KAS8 R/L Kontra
KAS10 R/L Kontra
KI2F R/L
KI3F R/L
KI3W R/L
KI4W R/L
KI5W R/L
KT3 R/L
KT4 R/L
KT5 R/L
KT6 R/L
KTM2 R/L Kontra
KTM3 R/L Kontra
KTS3 R/L Kontra
KTS4 R/L Kontra
KTS5 R/L Kontra
KTS6 R/L Kontra
KTS8 R/L Kontra
KTS10 R/L Kontra
MKI3F R/L
<b>Kühlmitteldüse / Coolant jet / Ugello refrigerante</b>
KMD 0519
KMD 0830
KMD 0818

Artikel / Item / Articolo
<b>Schraube / Screw / Vite</b>
AS0018
AS0019
AS0020
M154
SS1111
T154
T205
T206
<b>Schlüssel / Key / Chiave</b>
KS1111
KVR16
KVR20
KVR25
T5120

Stechen

2

ISO	Werkstoff	Zugfestigkeit (N/mm <sup>2</sup> )	Schnittgeschwindigkeit V <sub>c</sub> (m/min)											
			beschichtet							unbeschichtet		hochharte		
			AM27C	AM35C	AM350	AM5035	AR17C	AR27C	AT10	AK10	CERMET	AH7520	AN8020	
P	Unlegierter Stahl und Stahlguss	< 0,15 % C/vergütet	350	140-260	120-160	140-200	140-200	150-250	160-280	-	-	130-400	-	-
		0,15 – 0,45 % C/vergütet	650	110-190	60-140	110-150	110-150	110-180	120-200	-	-	100-325	-	-
		> 0,45 % C/vergütet	1000	100-160	70-110	90-120	90-120	90-160	100-130	-	-	80-275	-	-
	Niedrig legierter Stahl und Stahlguss	geglüht	600	130-220	70-100	130-180	130-180	100-170	150-230	-	-	100-250	-	-
		vergütet	900	120-160	70-100	100-150	100-150	80-150	130-180	-	-	90-300	-	-
			1200	100-160	60-90	90-120	90-120	70-120	100-150	-	-	60-150	-	-
	Hochlegierter Stahl	geglüht	700	120-150	60-80	90-150	90-150	90-130	140-170	-	-	80-180	-	-
Hochlegierter Werkzeugstahl und Stahlguss	gehärtet und angelassen	1100	90-120	60-80	70-120	70-120	70-110	90-130	-	-	60-140	-	-	
Nichtrostender Stahl	ferritisch, geglüht	700	140-250	90-120	110-180	110-180	110-170	140-240	-	-	80-220	-	-	
Stahlguss	martensitisch, vergütet	1000	120-150	60-90	60-90	60-90	90-140	60-100	-	-	70-180	-	-	
M	Nichtrostender Stahl	austenitisch und austenitisch/ ferritisch, abgeschreckt	450-600	130-200	100-180	110-200	110-200	80-140	130-200	-	-	100-250	-	-
			600-900	80-130	80-150	80-120	80-120	70-100	80-130	-	-	80-180	-	-
K	Grauguss	perlitisch/ferritisch	500-700	-	-	-	-	120-160	130-220	140-200	120-160	-	-	-
		perlitisch/martensitisch	700-850	-	-	-	-	120-150	100-160	120-170	100-140	-	-	-
			800-1100	-	-	-	-	100-130	100-130	100-140	80-120	-	-	-
	Gusseisen mit Kugelgraphit	ferritisch	550	-	-	-	-	160-200	160-230	110-180	90-150	220-300	-	-
		perlitisch	800	-	-	-	-	100-140	120-170	120-220	100-180	180-230	-	-
Temperguss	ferritisch	450	-	-	-	-	120-140	150-210	120-250	100-200	250-350	-	-	
	perlitisch	750	-	-	-	-	90-130	120-200	100-200	80-160	160-250	-	-	
N	Aluminium-Knetlegierungen	nicht aushärtbar	200	-	-	-	-	-	-	120-950	100-800	-	-	-
		aushärtbar, ausgehärtet	350	-	-	-	-	-	-	100-950	80-800	-	-	350-3000
	Aluminium-Gusslegierungen	≤ 12 % Si, ausgehärtet	250	-	-	-	-	-	-	100-600	80-500	-	-	350-3000
		≤ 12 % Si, aushärtbar, ausgehärtet	300	-	-	-	-	-	-	-	-	-	-	350-3000
		≤ 12 % Si, nicht aushärtbar	450	-	-	-	-	-	-	-	-	-	-	350-3000
	Kupfer und Kupferlegierungen (Bronze/Messing)	Automatenlegierung, Pb > 1 %	400	-	-	-	-	-	-	120-300	100-250	-	-	350-3000
Messing, Rotguss		300	-	-	-	-	-	-	250-600	200-500	-	-	600-1200	
Aluminiumbronze		500	-	-	-	-	-	-	300-600	250-500	-	-	600-1200	
Kupfer und Elektrolytkupfer		200	-	-	-	-	-	-	150-350	130-300	-	-	600-1200	
Nichtmetallische Werkstoffe	Duroplaste	-	-	-	-	-	-	-	120-600	100-500	-	-	600-1200	
	Faserverstärkte Kunststoffe	-	-	-	-	-	-	-	100-180	80-150	-	-	80-1500	
	Hartgummi	-	-	-	-	-	-	-	120-250	100-200	-	-	80-1500	
S	Warmfeste Legierungen	Fe-Basis, geglüht	700	30-50	-	-	-	30-50	25-45	-	-	-	-	80-1500
		Fe-Basis, ausgehärtet	950	25-40	20-40	20-40	20-40	25-35	20-40	-	-	-	-	-
		Ni- oder Co-Basis, geglüht	800	10-30	20-30	20-30	20-30	15-25	15-25	-	-	-	-	-
		Ni- oder Co-Basis, gegossen	1100	10-20	-	-	-	10-20	10-20	-	-	-	-	-
		Ni- oder Co-Basis, ausgehärtet	1200	10-15	-	-	-	10-25	10-20	-	-	-	-	-
	Titanlegierungen	Rein-Titan	500-700	-	-	-	-	100-150	-	100-150	80-130	-	-	60-80
Alpha+Beta-Legierungen	ausgehärtet	700-1000	-	-	-	-	40-60	-	50-80	40-70	-	-	50-70	
H	Gehärteter Stahl	gehärtet und angelassen	55 HRC	-	-	-	-	35-45	10-20	-	-	-	-	-
			60 HRC	-	-	-	-	-	-	-	-	-	-	80-230
	Hartguss	gegossen	41 HRC	-	-	-	-	10-20	10-20	-	-	-	60-180	-
Gehärtetes Gusseisen	gehärtet und angelassen	55 HRC	-	-	-	-	35-45	10-20	-	-	-	80-230	-	

Die Tabellenwerte sind Richtwerte. Es kann notwendig sein, die Werte den jeweiligen Bearbeitungsumständen anzupassen.

Grooving

ISO	Material	Tensile strength (N/mm <sup>2</sup> )	Cutting speed V <sub>c</sub> (m/min)											
			coated							uncoated		ultra-hard		
			AM27C	AM35C	AM350	AM5035	AR17C	AR27C	AT10	AK10	CERMET	AH7520	AN8020	
P	Unalloyed steel and cast steel	< 0.15% C/hardened and tempered	350	140-260	120-160	140-200	140-200	150-250	160-280	-	-	130-400	-	-
		0.15-0.45% C/hardened and tempered	650	110-190	60-140	110-150	110-150	110-180	120-200	-	-	100-325	-	-
		> 0.45% C/hardened and tempered	1000	100-160	70-110	90-120	90-120	90-160	100-130	-	-	80-275	-	-
	Low alloyed steel and cast steel	annealed	600	130-220	70-100	130-180	130-180	100-170	150-230	-	-	100-250	-	-
		hardened and tempered	900	120-160	70-100	100-150	100-150	80-150	130-180	-	-	90-300	-	-
			1200	100-160	60-90	90-120	90-120	70-120	100-150	-	-	60-150	-	-
	High alloyed steel	annealed	700	120-150	60-80	90-150	90-150	90-130	140-170	-	-	80-180	-	-
High alloyed tool steel and cast steel	hardened	1100	90-120	60-80	70-120	70-120	70-110	90-130	-	-	60-140	-	-	
Stainless steel	ferritic, annealed	700	140-250	90-120	110-180	110-180	110-170	140-240	-	-	80-220	-	-	
Cast steel	martensitic, hardened and tempered	1000	120-150	60-90	60-90	60-90	90-140	60-100	-	-	70-180	-	-	
M	Stainless steel	austenitic and austenitic/ ferritic, chilled	450-600	130-200	100-180	110-200	110-200	80-140	130-200	-	-	100-250	-	-
		pearlitic/ferritic	500-700	-	-	-	-	120-160	130-220	140-200	120-160	-	-	-
K	Cast iron	pearlitic/martensitic	700-850	-	-	-	-	120-150	100-160	120-170	100-140	-	-	
		800-1100	-	-	-	-	100-130	100-130	100-140	80-120	-	-	-	
			800-1100	-	-	-	-	100-130	100-130	100-140	80-120	-	-	-
Cast iron with nodular graphite	ferritic	550	-	-	-	-	160-200	160-230	110-180	90-150	220-300	-	-	
	pearlitic	800	-	-	-	-	100-140	120-170	120-220	100-180	180-230	-	-	
Malleable cast iron	ferritic	450	-	-	-	-	120-140	150-210	120-250	100-200	250-350	-	-	
	pearlitic	750	-	-	-	-	90-130	120-200	100-200	80-160	160-250	-	-	
N	Aluminium alloys long chipping	not heat treatable	200	-	-	-	-	-	120-950	100-800	-	-	-	
		heat treatable, heat treated	350	-	-	-	-	-	100-950	80-800	-	-	350-3000	
	Casted aluminium alloys	≤ 12% Si, heat treated	250	-	-	-	-	-	-	100-600	80-500	-	-	350-3000
		≤ 12% Si, not heat treatable	450	-	-	-	-	-	-	-	-	-	-	350-3000
Copper and copper alloys (Brass/Bronze)	Lead alloys, Pb > 1%	400	-	-	-	-	-	-	120-300	100-250	-	-	350-3000	
	Brass, Bronze	300	-	-	-	-	-	-	250-600	200-500	-	-	600-1200	
	Aluminium bronze	500	-	-	-	-	-	-	300-600	250-500	-	-	600-1200	
	Copper and elektrolyte copper	200	-	-	-	-	-	-	150-350	130-300	-	-	600-1200	
Non-ferrous materials	Duroplastic	-	-	-	-	-	-	-	120-600	100-500	-	-	600-1200	
	Re-inforced plastics	-	-	-	-	-	-	-	100-180	80-150	-	-	80-1500	
	Hard rubber	-	-	-	-	-	-	-	120-250	100-200	-	-	80-1500	
S	High temperature resistant alloys	Fe-alloyed, annealed	700	30-50	-	-	-	30-50	25-45	-	-	-	80-1500	
		Fe-alloyed, heat treated	950	25-40	20-40	20-40	20-40	25-35	20-40	-	-	-	-	
		Ni- or Co-alloyed, annealed	800	10-30	20-30	20-30	20-30	15-25	15-25	-	-	-	-	
		Ni- or Co-alloyed, casting	1100	10-20	-	-	-	10-20	10-20	-	-	-	-	-
		Ni- or Co-alloyed, heat treated	1200	10-15	-	-	-	10-25	10-20	-	-	-	-	-
Titanium alloys	Pure titan	500-700	-	-	-	-	100-150	-	100-150	80-130	-	-	60-80	
Alpha- and Beta-alloys	heat treated	700-1000	-	-	-	-	40-60	-	50-80	40-70	-	-	50-70	
H	Hardened steel	hardened	55 HRC	-	-	-	-	35-45	10-20	-	-	-	-	
		60 HRC	-	-	-	-	-	-	-	-	-	80-230	-	
	Hard cast iron	casting	41 HRC	-	-	-	-	10-20	10-20	-	-	-	60-180	
	Hardened cast iron	hardened	55 HRC	-	-	-	-	35-45	10-20	-	-	-	80-230	

The recommended cutting data are only approximate values.  
It may be necessary to adjust them to each individual machining application.

Scanalatura

ISO	Materiale	Resistenza (N/mm <sup>2</sup> )	Velocità di taglio Vc (m/min)												
			rivestito							non rivestito		extra duri			
			AM27C	AM35C	AM350	AM5035	AR17C	AR27C	AT10	AK10	CERMET	AH7520	AN8020		
P	Acciai non legati	< 0,15 % C/bonificato	350	140-260	120-160	140-200	140-200	150-250	160-280	-	-	130-400	-	-	
		0,15 - 0,45 % C/bonificato	650	110-190	60-140	110-150	110-150	110-180	120-200	-	-	100-325	-	-	
		> 0,45 % C/bonificato	1000	100-160	70-110	90-120	90-120	90-160	100-130	-	-	80-275	-	-	
	Acciai debolmente legati e Ghise acciaiose	ricotto	600	130-220	70-100	130-180	130-180	100-170	150-230	-	-	100-250	-	-	
		bonificato	900	120-160	70-100	100-150	100-150	80-150	130-180	-	-	90-300	-	-	
			1200	100-160	60-90	90-120	90-120	70-120	100-150	-	-	60-150	-	-	
	Acciai fortemente legati	ricotto	700	120-150	60-80	90-150	90-150	90-130	140-170	-	-	80-180	-	-	
	Acciai da utensili e fusioni	temprato e rinvenuto	1100	90-120	60-80	70-120	70-120	70-110	90-130	-	-	60-140	-	-	
Acciai inossidabili	ferritico, ricotto	700	140-250	90-120	110-180	110-180	110-170	140-240	-	-	80-220	-	-		
Ghisa acciaiosa	martensitico, bonificato	1000	120-150	60-90	60-90	60-90	90-140	60-100	-	-	70-180	-	-		
M	Acciai inossidabili	austenitico e autenitico/	450-600	130-200	100-180	110-200	110-200	80-140	130-200	-	-	100-250	-	-	
		ferritico, trattato o temperato	600-900	80-130	80-150	80-120	80-120	70-100	80-130	-	-	80-180	-	-	
K	Ghisa grigia	perlitica/ferritico	500-700	-	-	-	-	120-160	130-220	140-200	120-160	-	-	-	
		perlitica/martensitico	700-850	-	-	-	-	120-150	100-160	120-170	100-140	-	-	-	
			800-1100	-	-	-	-	100-130	100-130	100-140	80-120	-	-	-	
	Ghisa sferoidale	ferritico	550	-	-	-	-	160-200	160-230	110-180	90-150	220-300	-	-	
		perlitica	800	-	-	-	-	100-140	120-170	120-220	100-180	180-230	-	-	
	Ghisa temprata	ferritico	450	-	-	-	-	120-140	150-210	120-250	100-200	250-350	-	-	
perlitica		750	-	-	-	-	90-130	120-200	100-200	80-160	160-250	-	-		
N	Leghe di Alluminio stampato	non invecchiato	200	-	-	-	-	-	-	120-950	100-800	-	-	-	
		invecchiato	350	-	-	-	-	-	-	100-950	80-800	-	-	350-3000	
	Leghe di Alluminio da fusione	≤ 12 % Si, invecchiato	250	-	-	-	-	-	-	-	100-600	80-500	-	-	350-3000
		≤ 12 % Si, rinvenuto, invecchiato	300	-	-	-	-	-	-	-	-	-	-	-	350-3000
		≤ 12 % Si, non invecchiato	450	-	-	-	-	-	-	-	-	-	-	-	350-3000
	Rame e Leghe di Rame (Bronzo/Ottone)	Automatici, Pb > 1 %	400	-	-	-	-	-	-	-	120-300	100-250	-	-	350-3000
		Ottone, Bronzo	300	-	-	-	-	-	-	-	250-600	200-500	-	-	600-1200
Bronzoalluminio		500	-	-	-	-	-	-	-	300-600	250-500	-	-	600-1200	
Rame e Rame Elettrolitico		200	-	-	-	-	-	-	-	150-350	130-300	-	-	600-1200	
Materiali non metallici	Duroplastiche	-	-	-	-	-	-	-	-	120-600	100-500	-	-	600-1200	
	Plastiche rinforzate	-	-	-	-	-	-	-	-	100-180	80-150	-	-	80-1500	
	Gomme dure	-	-	-	-	-	-	-	-	120-250	100-200	-	-	80-1500	
S	Leghe resistenti al calore	Base-Fe, ricotto	700	30-50	-	-	-	30-50	25-45	-	-	-	-	80-1500	
		Base-Fe, invecchiato	950	25-40	20-40	20-40	20-40	25-35	20-40	-	-	-	-	-	
		Base Ni o Co, ricotto	800	10-30	20-30	20-30	20-30	15-25	15-25	-	-	-	-	-	
		Base Ni o Co, da fusione	1100	10-20	-	-	-	10-20	10-20	-	-	-	-	-	-
		Base Ni o Co, invecchiato	1200	10-15	-	-	-	10-25	10-20	-	-	-	-	-	-
	Leghe di Titanio	Titanio puro	500-700	-	-	-	-	100-150	-	100-150	80-130	-	-	60-80	
Leghe Alpha+Beta	invecchiato	700-1000	-	-	-	-	40-60	-	50-80	40-70	-	-	50-70		
H	Acciaio Temprato	temprato e rinvenuto	55 HRC	-	-	-	-	35-45	10-20	-	-	-	-	-	
		60 HRC	-	-	-	-	-	-	-	-	-	-	80-230	-	
	Getti Temprati	da fusione	41 HRC	-	-	-	-	10-20	10-20	-	-	-	60-180	-	
	Ghisa Temprata	temprato e rinvenuto	55 HRC	-	-	-	-	35-45	10-20	-	-	-	80-230	-	

I dati indicati in tabella sono valori approssimati. Può essere necessario adattarli alle singole applicazioni di lavorazione.

Recommended cutting data  
Parametri di taglio suggeriti

## Maximale Vorschübe und Spantiefen

Max. feed rate and depth of cut

Avanzamenti e profondità di taglio massimi

- $f_v$  (mm/U) = **Vorschub ins Volle** / Feed rate into solid / Avanzamento nel pieno
- $f_n$  (mm/U) = **Vorschub beim Einstechen** / Feed rate for re-grooving / Avanzamento di ripresa
- $f_k$  (mm/U) = **Vorschub beim Kopieren** / Feed rate for copying / Avanzamento per copiatura
- $a_p$  (mm) = **Spantiefe** / Depth of cut / Profondità di taglio

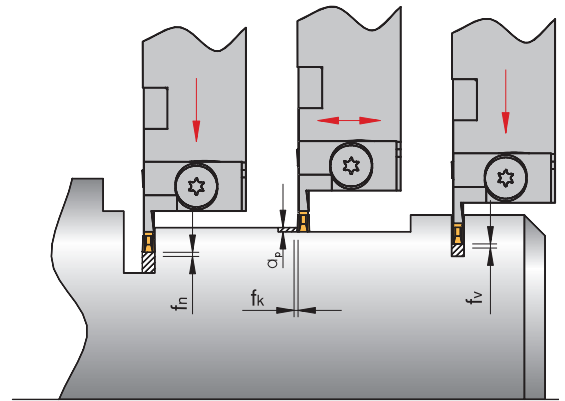

## Standardausführung / Standard geometry / Esecuzione standard

	Schneideinsatz / Insert / Inserto							
	21201	31602	32002	42202	52502	63002	83804	104604
$f_v$	0,02–0,08	0,02–0,08	0,05–0,12	0,07–0,18	0,07–0,18	0,07–0,18	0,10–0,25	0,10–0,25
$f_n$	0,02–0,08	0,02–0,08	0,05–0,12	0,07–0,18	0,07–0,18	0,07–0,18	0,10–0,30	0,10–0,30
$f_k$	0,02–0,05	0,02–0,05	0,05–0,10	0,05–0,10	0,05–0,10	0,07–0,15	0,12–0,25	0,12–0,25
$a_p \text{ max}$	0,30	0,30	0,50	0,50	0,50	0,50	1,00	1,00

## Kopierausführung / Geometry for copying / Geometria a copiare

-12

	Schneideinsatz / Insert / Inserto							
	21201-12	31602-12	32002-12	42202-12	52502-12	63002-12	83804-12	104604-12
$f_v$	0,02–0,08	0,02–0,08	0,05–0,15	0,07–0,18	0,07–0,18	0,07–0,18	0,10–0,18	0,10–0,18
$f_n$	0,02–0,08	0,02–0,08	0,05–0,15	0,07–0,18	0,07–0,18	0,07–0,18	0,10–0,30	0,10–0,30
$f_k$	0,02–0,05	0,02–0,05	0,05–0,10	0,07–0,18	0,07–0,18	0,07–0,18	0,10–0,30	0,10–0,40
$a_p \text{ max}$	0,50	0,50	1,50	2,00	2,50	2,50	3,50	4,00

## Stechdrehen / Groove turning / Scanalatura di copiatura

-AM

	Schneideinsatz / Insert / Inserto							
	21202-AM	31602-AM	32002-AM	42204-AM	52504-AM	63008-AM	83808-AM	104608-AM
$f_v$	0,02–0,08	0,02–0,08	0,04–0,15	0,07–0,18	0,07–0,25	0,10–0,25	0,10–0,40	0,10–0,40
$f_n$	0,02–0,08	0,02–0,08	0,04–0,15	0,07–0,18	0,07–0,25	0,10–0,25	0,10–0,40	0,10–0,40
$f_k$	0,02–0,12	0,02–0,12	0,04–0,15	0,07–0,18	0,07–0,25	0,10–0,25	0,10–0,40	0,10–0,40
$a_p \text{ max}$	0,50	0,50	1,50	2,00	2,50	2,50	3,50	4,00

## Vollradiusausführung / Full radius execution / Esecuzione a raggio completo

-V

	Schneideinsatz / Insert / Inserto							
	21210 V	31615 V	32015 V	42220 V	52525 V	63030 V	83840 V	104650 V
$f_v$	0,02–0,05	0,02–0,05	0,05–0,10	0,05–0,10	0,05–0,10	0,07–0,12	0,07–0,15	0,07–0,15
$f_n$	0,02–0,05	0,02–0,05	0,05–0,10	0,05–0,10	0,05–0,10	0,07–0,12	0,07–0,15	0,07–0,15
$f_k$	0,02–0,05	0,02–0,05	0,05–0,10	0,05–0,10	0,05–0,10	0,07–0,12	0,07–0,15	0,07–0,15
$a_p \text{ max}$	0,30	0,30	0,50	0,50	0,50	0,50	1,00	1,00

Die Tabellenwerte sind Richtwerte. Es kann notwendig sein, die Werte den jeweiligen Bearbeitungsumständen anzupassen.  
The recommended cutting data are only approximate values. It may be necessary to adjust them to each individual machining application.  
I dati indicati in tabella sono valori approssimati. Può essere necessario adattarli alle singole applicazioni di lavorazione.



## Vollradiusausführung / Full radius execution / Esecuzione a raggio completo

-VK

	Schneideinsatz / Insert / Insetto							
	21210 VK	31615 VK	32015 VK	42220 VK	52525 VK	63030 VK	83840 VK	104650 VK
$f_v$	0,02–0,05	0,02–0,05	0,05–0,12	0,05–0,12	0,05–0,12	0,07–0,12	0,07–0,15	0,07–0,15
$f_n$	0,02–0,05	0,02–0,05	0,05–0,12	0,05–0,12	0,05–0,12	0,07–0,25	0,07–0,30	0,07–0,30
$f_k$	0,02–0,05	0,02–0,05	0,05–0,15	0,05–0,12	0,08–0,12	0,07–0,30	0,07–0,30	0,07–0,40
$a_p \text{ max}$	0,50	0,50	1,50	2,00	2,50	3,00	4,00	5,00

## Aluminiumausführung / Aluminium geometry / Geometria alluminio

-ALU

	Schneideinsatz / Insert / Insetto							
	21201-ALU	31602-ALU	32002-ALU	42202-ALU	52502-ALU	63002-ALU	83804-ALU	104604-ALU
$f_v$	0,02–0,08	0,02–0,12	0,05–0,18	0,05–0,18	0,05–0,18	0,05–0,18	0,10–0,25	0,10–0,25
$f_n$	0,02–0,08	0,02–0,12	0,05–0,18	0,05–0,18	0,05–0,18	0,05–0,18	0,10–0,30	0,10–0,30
$f_k$	0,02–0,10	0,02–0,15	0,05–0,20	0,05–0,20	0,05–0,20	0,05–0,20	0,10–0,35	0,10–0,35
$a_p \text{ max}$	0,50	0,50	2,00	2,50	3,00	3,00	4,00	5,00

2

## Ausführung für Sicherungsringestiche / Circlip inserts / Insetti per sedi seeger

	Schneideinsatz / Insert / Insetto		
	2-...	3M-...	3-...
$f_v$	0,01–0,05	0,01–0,05	0,01–0,10

Die Tabellenwerte sind Richtwerte. Es kann notwendig sein, die Werte den jeweiligen Bearbeitungsumständen anzupassen.

The recommended cutting data are only approximate values. It may be necessary to adjust them to each individual machining application.

I dati indicati in tabella sono valori approssimati. Può essere necessario adattarli alle singole applicazioni di lavorazione.

## Auswahl des Halters / Selecting the toolholder / Scelta dello stelo

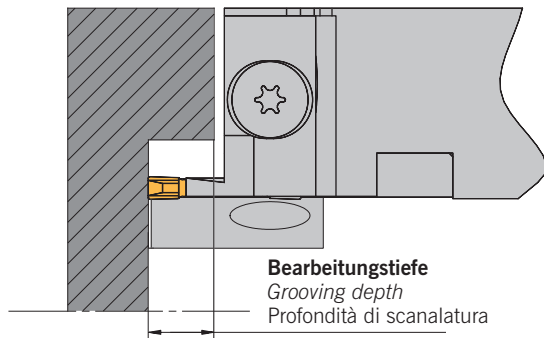

Einsatz eines Halters mit maximalen Schaftabmessungen. Zur Vermeidung oder Minimierung von Vibrationen und Werkzeugauslenkung, Auswahl des Werkzeuges (Halter, Unterstützplatte) mit der geringsten Auskraglänge, entsprechend der geforderten Bearbeitungstiefe.

*The maximum shank cross section should be used. In order to minimize vibration, the tool and support blade should be setup with minimum overhang.*

Scegliere lo stelo dalla sezione massima di gambo. Per ridurre le vibrazioni, l'utensile e la lama devono essere montati con una sporgenza minima.

## Auswahl des Schneideinsatzes / Selecting the inserts / Scelta dell'inserto

Die Breite des Schneideinsatzes sollte, bezogen auf die Abmessungen des Werkzeuges, so breit wie möglich gewählt werden, um eine optimale Stabilität zu erreichen. Die Breite des Schneideinsatzes hat unmittelbare Auswirkung auf die Auskraglänge des Werkzeuges. Es ist der größtmögliche Eckenradius zu wählen. Ein Schneideinsatz mit größerem Radius ist stabiler und garantiert längere Standzeit durch bessere Verteilung der Schnittkräfte. Ein größerer Radius erhöht in der Regel die Oberflächenqualität beim Drehen. Der Radius sollte größer sein als der maximal gewählte Vorschub. Die kleinste Schnitttiefe „ $a_p$ “ sollte nicht kleiner sein als der Eckenradius des Schneideinsatzes.

*In order to achieve maximum stability, the widest possible insert (depending on the size of the tool) should be selected. The grooving depth of the tool is depending on the width. The largest possible corner radius should be used. A insert with a larger corner radius gives more stability and better tool-life, as the cutting forces are equalized. A large corner radius improves the surface quality. The radius should be larger than the maximum feed rate. The smallest depth cut should not be less than the corner radius of the insert.*

Per ottenere la massima stabilità, è consigliabile selezionare l'inserto più largo possibile (considerando la misura dell'utensile). La profondità di scanalatura dell'utensile dipende dalla larghezza. È suggerito scegliere raggi di punta più ampi possibili. Un inserto di scanalatura con raggio di punta ampio dà maggiore stabilità e durata, e le forze di taglio contenute. Un raggio di punta ampio permette una migliore qualità superficiale. Il raggio dovrebbe essere più largo dell'avanzamento massimo. La profondità di taglio più piccola non dovrebbe essere minore del raggio di punta dell'inserto di scanalatura.

## Einrichten des Werkzeuges / Set up of the tool / Installazione dell'utensile

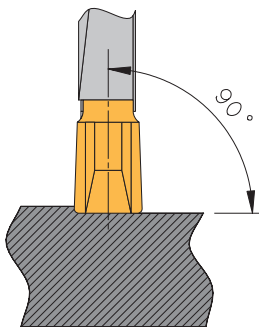

Optimale Bearbeitungsergebnisse sind nur zu erzielen, wenn das Werkzeug sachgemäß eingerichtet ist. Hierbei ist zu beachten, dass das Werkzeug (Schneidkante) stets rechtwinklig (bzw. parallel beim Axial-Stechdrehen) zur Werkstückrotationsachse ausgerichtet wird. Beim Kopierdrehen ist die zweite Schneidenecke um 0,05 mm freizustellen.

**ACHTUNG:** Bei unsachgemäßer Ausrichtung der Schneidkante können Vibrationen auftreten.

*Optimal processing results can only be achieved if the tool is correctly mounted. Whereby it should be noted that the tool (cutting edge) must be always mounted at right angles to the work piece rotating axis (or respectively parallel with axial groove turning). With duplicating turning, the second corner is to be released 0.05 mm.*

**ATTENTION:** If cutting edges are not set correctly, vibration can be caused.

I migliori risultati di lavorazione possono essere ottenuti solo se l'utensile è montato correttamente. Per cui bisogna considerare che l'utensile (il tagliente) deve essere sempre montato ai corretti angoli rispetto all'asse rotante del pezzo da lavorare (o rispettivamente parallelo alla tornitura assiale del canale). In tornitura di copiatura, il secondo tagliente deve arretrare di 0,05 mm.

**ATTENZIONE:** Se i taglienti non vengono impostati correttamente si possono originare vibrazioni.

## Beispiele / Examples / Esempi

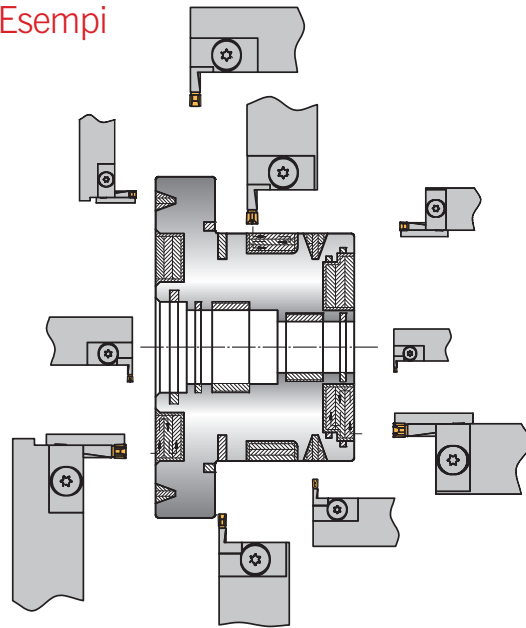

Die Schraffur macht die Schnittaufteilung deutlich und zeigt gleichzeitig die abschließende Kopieroperation.

- Musterteil aus 16MnCr5
- durchschnittliche Schnittgeschwindigkeit 150 m/min
- Vorschübe von 0,1 bis 0,25 mm.

The shaded area shows the sequence of operations as well as the final profiling cut, with the Nprecision grooving tools.

- A low tensile steel was used for this component
- Average cutting speed 150 m/min
- Feed rates 0.1 up to 0.25 mm/rev.

L'illustrazione mostra la sequenza delle operazioni la profilatura finale con l'uso degli utensili di scanalatura di precisione NC.

- Per questo esempio si utilizza un acciaio basso legato 16MnCr5
- Velocità di taglio 150 m/min
- Avanzamento da 0,1 a 0,25 mm.

2

## Einstechen ins Volle / Grooving into solid / Scanalatura nel pieno

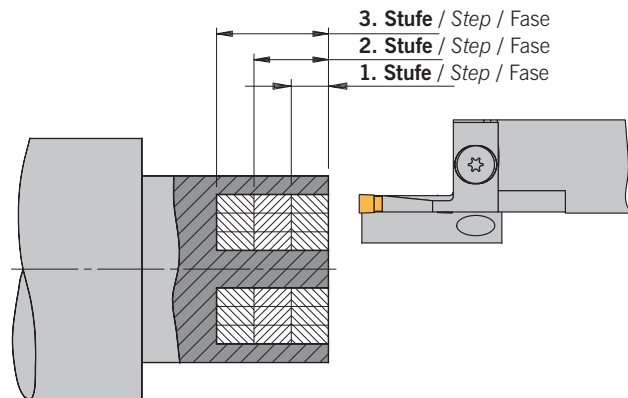

Bei großen Stechtiefen ist ein stufenweises Einstechen zu empfehlen, um Spanräume zu schaffen. Erst danach wird tiefer eingestochen.

If large groove depths are required, rough out in a series of plunges, before finishing the profile down each side and blending into the centre.

Se sono richieste scanalature profonde, procedere con una serie di passate al fine di creare uno spazio d'evacuazione del truciolo, poi scanalare più in profondità.

## Innenstechen / Internal grooving / Scanalatura interna

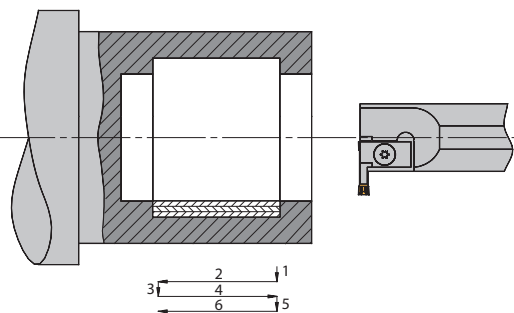

Verwendung der Schneideinsätze – 12 oder -AM

Using insert type – 12 or -AM

Utilizzo dell'inserto – 12 o -AM

## Ein- oder Auswärtskopieren

*Inward- and outward copy-turning*

Copiatura in entrata o in uscita

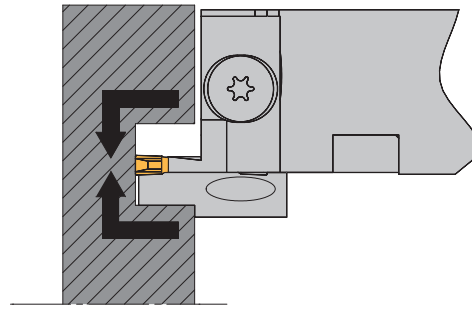

Einwärtskopieren bewirkt einen besseren, gleichmäßigeren Spanbruch und ist zur Minimierung des Werkzeugverschleißes zu empfehlen. Der Span fließt in den bearbeiteten Raum ab. Senkrecht / Rechtwinklig: Um eine gute Rechtwinkligkeit zwischen den Seitenwänden zu erhalten, empfiehlt sich das Einwärtskopieren.

*Inward copy-turning gives a more uniform chip-breaking and minimizes insert wear. In order to achieve rectangular faces, we recommend inward copy-turning.*

La copiatura in uscita permette una rottura del truciolo uniforme e minimizza l'usura dell'inserto. Perpendicolarità/Parallelismo: per ottenere una buona perpendicolarità ed un buon parallelismo raccomandiamo la copiatura in uscita.

## Axial-Stecken und Plandrehen

*Axial grooving and facing*

Scanalatura assiale e sfacciatura

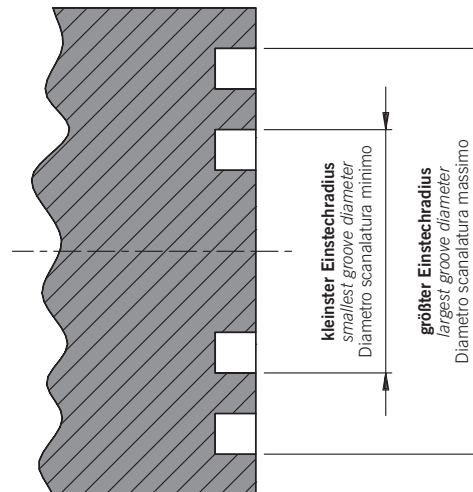

Axial-Stecken ist nur innerhalb des festgelegten Durchmesserbereiches möglich (z. B. 50–60). Andernfalls kann es zur Beschädigung oder Zerstörung des Werkzeuges kommen.

*Axial grooving is only possible within the diameter range (e. g. 50–60). If not, the tool can be damaged or destroyed.*

La scanalatura assiale è possibile solo entro la gamma di diametri determinati (per es. 50–60). Una scelta scorretta causerebbe la collisione tra utensile e pezzo da lavorare.

**ACHTUNG:** Der angegebene Durchmesserbereich gilt immer für den Außendurchmesser der Nut!

**ATTENTION:** The specified diameter range in all cases refers to the outer diameter of the groove!

**ATTENZIONE:** La gamma dei diametri specifici si riferisce in ogni caso al diametro più esterno della gola in prima piantata.

**ACHTUNG / ATTENTION / ATTENZIONE**

Beim Axial-Stechen immer am Nutaußendurchmesser starten.

Nutverbreiterungen über den angegebenen Durchmesserbereich hinaus sind nach oben und unten möglich.

Der erste Einstich muss im angegebenen Durchmesserbereich liegen. Die Tiefe der Einstiche zur Nutverbreiterung darf nicht größer als die des ersten Einstichs sein.

When axial grooving always begin at the groove outside diameter.

Once the first plunge is complete, it is possible to widen the groove above and below the diameter range quoted.

The first groove made must be within the quoted diameter range. The depth of the next cut must not be deeper than the depth of the first groove.

Nella scanalatura assiale occorre sempre iniziare con il diametro esterno.

Una volta completata la prima piantata è possibile allargare il canale al di sopra e al di sotto della gamma di diametro lavorato.

Il primo canale prodotto deve essere entro la gamma diametro indicato sulla lama. La profondità della gola successiva non deve essere più profonda della profondità della prima.

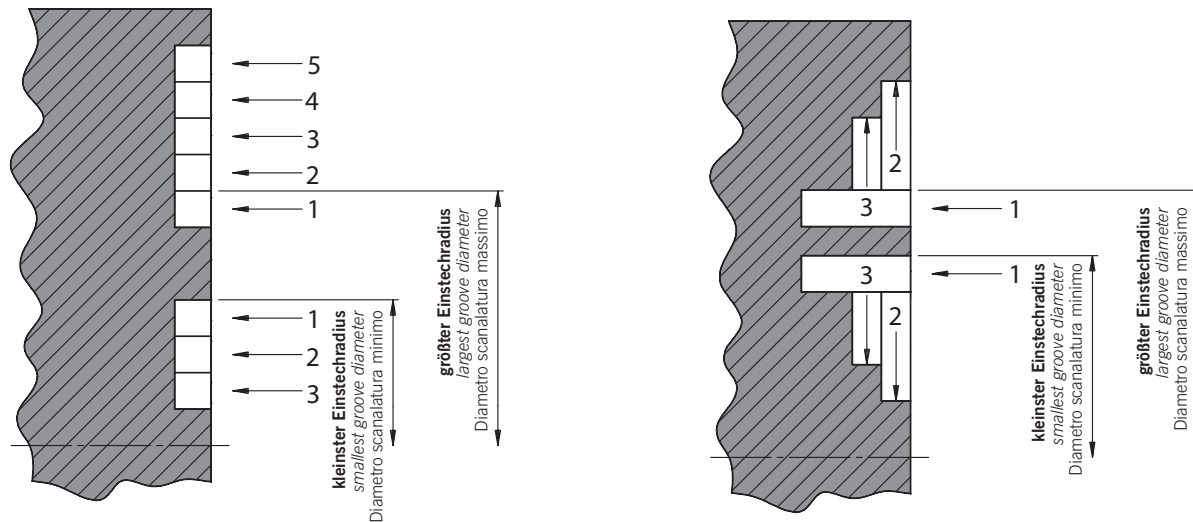



- Modulares NC-Stechnsystem für verschiedene Werkzeugvarianten mit einem Grundhalter durch einfachen Austausch von Unterst tzplatte und Klemme.
- Komplettes Programm f r die axiale und radiale Au enbearbeitung in verschiedenen Stechbreiten.
- F r die Innenbearbeitung besteht ein Programm in verschiedenen Haltergr ssen (wahlweise mit oder ohne innere K hlmittelzufuhr) und Stechbreiten.
- F r gr ssere Bearbeitungstiefen stehen spezielle Klemmen und Unterst tzplatten zur Verf gung.
- Kompakthalter mit VDI- und UTS-/KM und Capto®-Aufnahmen f r erh hte Stabilit t. Diese Halter k nnen ebenfalls mit dem gesamten Standardzubeh r kombiniert werden.

- A modular grooving and copy-turning system giving different tool variations from one basic holder by simply exchanging the support blade and clamp.
- A complete programme for external radial and axial grooves of various widths.
- For internal machining a range of boring bars with and without coolant feed and inserts in different widths are available.
- For deep grooving applications special support blades and clamps can be designed and manufactured.
- Toolholder with VDI or UTS/KM and Capto® shanks, which can give improved stability, along with their spares are stock items. These holders are used in conjunction with standard support blades, clamps and inserts.

- Un sistema di tornitura-scanalatura modulare permette differenti varianti d'utensile con il semplice cambio della lama e della staffa.
- Un programma completo per lavorazioni esterne assiali e radiali con larghezze di taglio differenti.
- Per la lavorazione interna, esiste un programma di steli con sezioni differenti (con un sistema di raffreddamento centrale) e larghezze di taglio differenti.
- Per profondit  di taglio non standard   possibile studiare apposite lame e staffe speciali.
- Sono disponibili attacchi VDI, UTS/KM e Capto® per una stabilit  superiore. Questi attacchi possono essere combinati con l'insieme degli accessori standard.



- Pr zisionsgeschliffene bzw. gesinterte, 2-schneidige Schneideins tze f r die Innen- und Au enbearbeitung.
- Verschiedene Spanformgeometrien sowie eine Vielzahl von Schneidstoffen mit speziell abgestimmten Beschichtungen bieten eine optimale Auswahl f r den jeweiligen Bearbeitungsfall.
- Lange Prismenf hrung der Schneideins tze f r optimale Kontrolle der Schnittkr fte beim L ngsdrehen und Kopieren.
- Positive Schneidgeometrie erlaubt Programmkorrekturen im Bereich von 0,01 mm und eignet sich somit f r Schlichtoperationen aller Art.

- Precision or sintered ground inserts with two cutting edges for use on internal and external grooving applications.
- A choice of chipbreaker geometries together with coated and uncoated carbide grades, combine to offer optimum cutting performance on a wide range of materials.
- Inserts have a ground vee seating for a positive location into the support blade. This ensures maximum stability when side turning or copying.
- The positive insert geometry minimises deflection (less than 0.01 mm) and is therefore particularly suitable for finishing operations.

- Inserti a due taglienti rettificati di precisione o sinterizzati per lavorazioni interne ed esterne.
- Le differenti geometrie di taglio insieme alla grande diversit  di gradi con rivestimenti specifici offrono una scelta ottimale per qualsiasi lavorazione.
- La lunghezza del prisma dell'inserto offre un controllo ottimale delle forze di taglio nella tornitura longitudinale e nella copiatura.
- La geometria di taglio positiva permette delle correzioni di programmazione nell'ordine di 0,01 mm e favorisce tutte le lavorazioni di finitura.

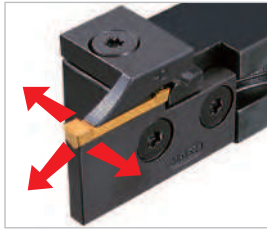

- **Stechdrehen in 3 verschiedene Hauptschnitt-richtungen. Dadurch Verbundoperationen mit nur einem Werkzeug möglich.**

- *Tools and operate in three directions offering the opportunity to consolidate several operations into one and reduce the number of tool changes.*

- La tornitura-copiatura tri-direzionale è ottenuta con un solo utensile.

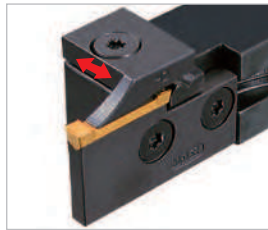
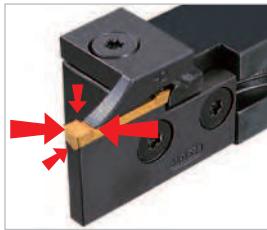

- **Die Klemmtechnik in Verbindung mit der Prismenführung verhindert ein seitliches Abkippen der Schneideinsatz bei Längsdrehoperationen und sichert durch die breite axiale Auflage die hohe Wiederholgenauigkeit.**
- **Die freigestellte Unterstützplatte garantiert eine optimale Plattenauflage und sichert die Stabilität bei einseitigen Belastungen.**

- *The design of the insert clamping and the vee location provides for accurate indexing of insert edges and index repeatability is achievable.*
- *The relief in the support blade means the insert is supported under the ends to ensure high stability and optimum rigidity.*

- La tecnica di serraggio, associata al prisma dell'inserto permette di evitare il suo movimento all'interno della sede.
- Il sostegno della lama di supporto garantisce una stabilità ottimale dell'inserto nella sua sede e assicura la stabilità negli sforzi di taglio laterali.



- **Zur Komplettierung des Stechdrehprogrammes stehen weiterhin Monoblock-Halter im Axialbereich für Nut-Außendurchmesser ab  $D_{min}$  15 mm und Mini-Innenstechdrehwerkzeuge ab  $D_{min}$  11 mm zur Verfügung.**

- *To complete the grooving programme, there are monoblock holders for axial grooving diameters of 15 mm upward. Also an internal boring bar for 11 mm minimum bore diameter are available.*

- Per completare il programma di tornitura-copiatura, esistono anche utensili monoblocco, per lavorazione assiale, per diametri esterni minimi di 15 mm. La gamma prevede inoltre utensili per interni come i sistemi AMS e SIM per diametri a partire da 2,5 mm.

## Montage ARNO-NC-Stechdrehsystem

Assembling of ARNO-Groove turning system

Montaggio del sistema ARNO di Scanalatura e copiatura

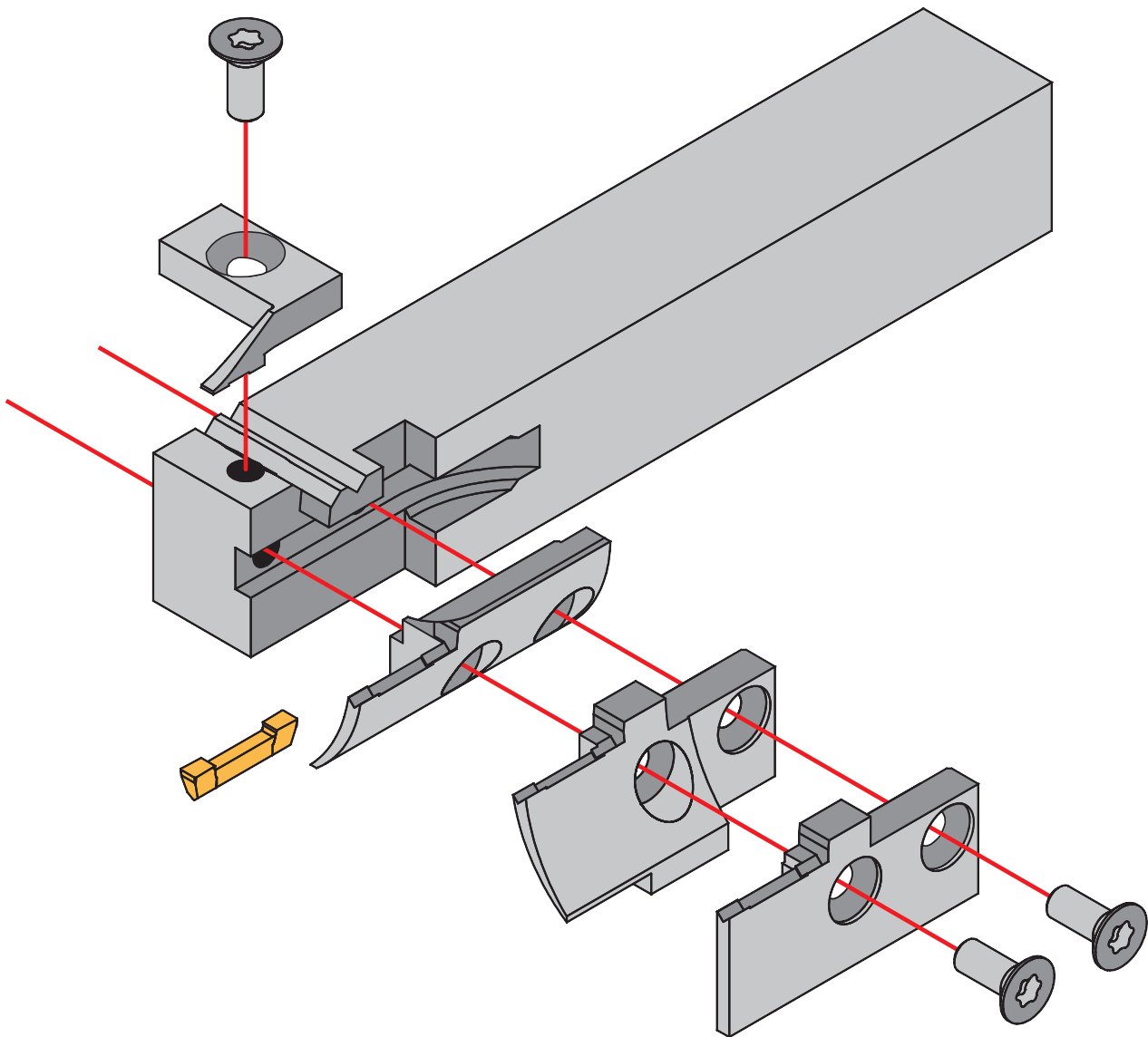
**2**

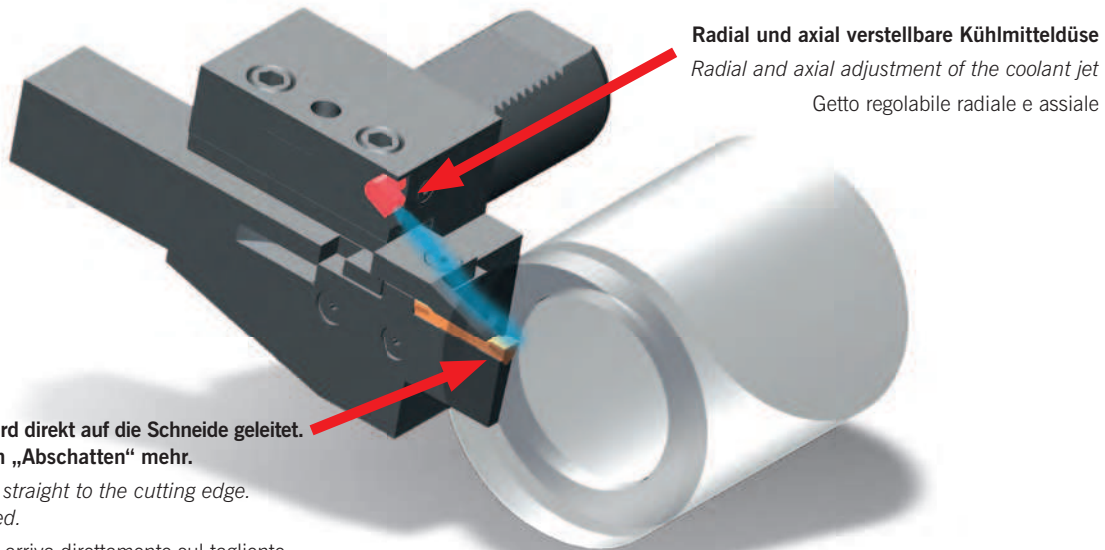

**Systemübersicht SBN/KMH** / System overview SBN/KMH/  
Panoramica del sistema SBN e KMH**KMH – Werkzeughalter** / KMH tool holder / Adattatori KMH**SBN Spannblock** / SBN Parting block / SBN Blocco portalama