

ARNO®-Frässystem Duo-Mill

- Systemvorstellung
- Bezeichnungssystem
- Werkzeugauswahl
- Trägerwerkzeuge
- Wendeschneidplatten
 - Geometriebeschreibung
 - Sortenbeschreibung
- Werkzeugaufnahmen
- Ersatzteile
- Schnittwerte
- Anwendungshinweise

ARNO®-Duo-Mill milling system

- *System introduction*
- *Designation system*
- *Tool shank options*
- *Holders*
- *Indexable inserts*
 - *Geometry description*
 - *Grade description*
- *Adaptors*
- *Spare parts*
- *Cutting data*
- *Application reference*

ARNO®-Sistema di fresatura Duo-Mill

- Caratteristiche del sistema **46 – 47**
- Sistema di numerazione **48**
- Tipologie di attacco utensile **49**
- Corpi fresa **50 – 55**
- Inserti **56 – 63**
 - Descrizione delle Geometrie **56 – 57**
 - Descrizione delle Qualità **58 – 59**
- Attacchi **64**
- Ricambi **65**
- Parametri di taglio **66 – 79**
- Suggerimenti tecnici **80 – 85**



Eckfräsen und HFC-Fräsen mit nur einem Werkzeug

Square shoulder and high feed (HFC) milling with just one tool

Spallamento retto e fresatura ad alto avanzamento con un solo corpo fresa

2

Duo-Mill ist ein Fräskonzept, mit dem es gelungen ist, 2 geometrisch verschiedene Wendeschneidplatten in einem Plattensitz zu spannen.

Duo-Mill is a milling concept where we successfully can locate 2 geometrically different indexable inserts into the same insert pocket.
Duo-Mill è un innovativo concetto di fresatura che permette di alloggiare due inserti geometricamente diversi in un'unica sede.

Dies ermöglicht verschiedene Fräsbearbeitungen mit nur einem Trägerwerkzeug durch zwei unterschiedliche Anstellwinkel.

By changing the insert we offer different milling operations with just one cutter body.

La sola sostituzione dell'inserto permette di ottenere due operazioni di fresatura differenti utilizzando il medesimo corpo fresa.

1 Grundhalter für 2 verschiedene Bearbeitungsmöglichkeiten durch einfachen Austausch der Wendeschneidplatte.

1 holder for 2 different applications by a simple change of indexable insert.

1 corpo utensile per 2 applicazioni: basta cambiare l'inserto.

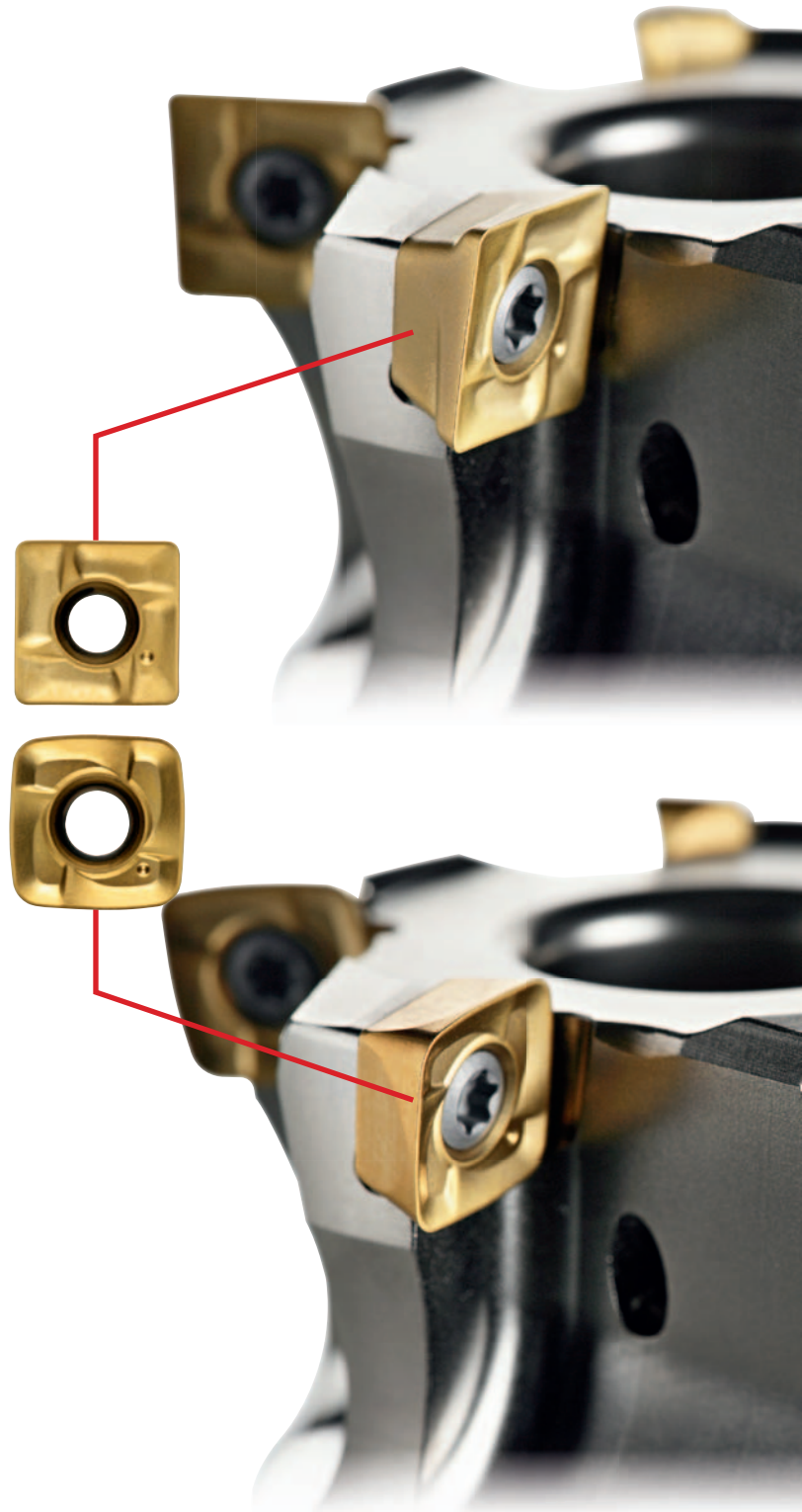



Fakten

- Eckfräsen und HFC-Fräsen mit nur einem Trägerwerkzeug.
 - ▶ **Maximale Einsparung von Werkzeugträgerkosten.**
- 2 verschiedene Wendeschneidplattengrößen auf gleichem Trägerwerkzeug montierbar.
 - ▶ **Hohe Flexibilität für viele Bearbeitungsaufgaben.**
- Schafffräser und Einschraubfräser von 25 mm – 42 mm Durchmesser und Aufsteckfräser von 40 mm – 160 mm Durchmesser.
 - ▶ **Durchgängiges Werkzeugprogramm für viele Bearbeitungsaufgaben.**
- Präzisionsgefertigte und geschliffene Wendeschneidplatten mit speziellen Geometrien.
 - ▶ **Kostengünstige und optimale Lösung für sichere Fräsbearbeitung.**
- 4 effektive Schneidkanten mit 90° beim Eck- und HFC-Fräsen.
 - ▶ **Höchste Effektivität.**

Features

- Square shoulder and HFC-milling with just one tool.
 - ▶ **Maximum savings on tool costs.**
- 2 different indexable inserts for the same tool.
 - ▶ **Flexibility for more applications.**
- Weldon shank and screw shank tools from diameter 25 mm – 42 mm and shell mill cutters from 40 mm – 160 mm diameter.
 - ▶ **Complete range for more applications.**
- Precision finished and ground indexable inserts with dedicated geometries.
 - ▶ **Cost efficient and optimum solutions for secure milling operations.**
- 4 effective cutting edges.
 - ▶ **Maximum efficiency.**

Caratteristiche

- Spallamento retto ed alto avanzamento con un solo utensile.
 - ▶ **Massima riduzione dei costi.**
- 2 diversi inserti per lo stesso corpo fresa.
 - ▶ **Flessibilità per più applicazioni..**
- Gamma corpi fresa con attacchi Weldon e con attacco filettato da 25 mm – 42 mm e dimensioni manicotti da 40 mm – 160 mm di diametro.
 - ▶ **Gamma completa per più applicazioni**
- Inserti precisi, rettificati e lappati con geometrie specifiche.
 - ▶ **Soluzioni ottimali per operazioni di fresatura.**
- Inserti a 4 taglienti effettivi. Fresatura a Spallamento Retto e HFC-Fresatura ad alto avanzamento
 - ▶ **Massima efficienza.**

Designation system
Sistema di numerazione

Trägerwerkzeuge / Holders / Corpi fresa



2

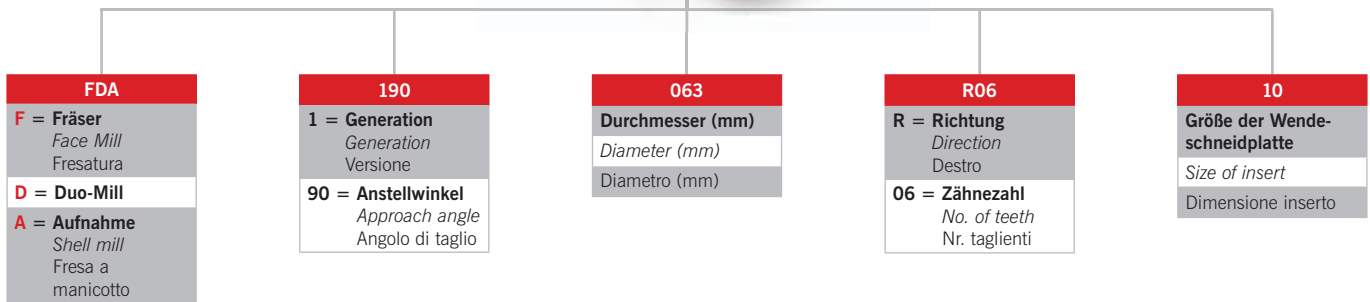

Wendeschneidplatten / Indexable Inserts / Inserti

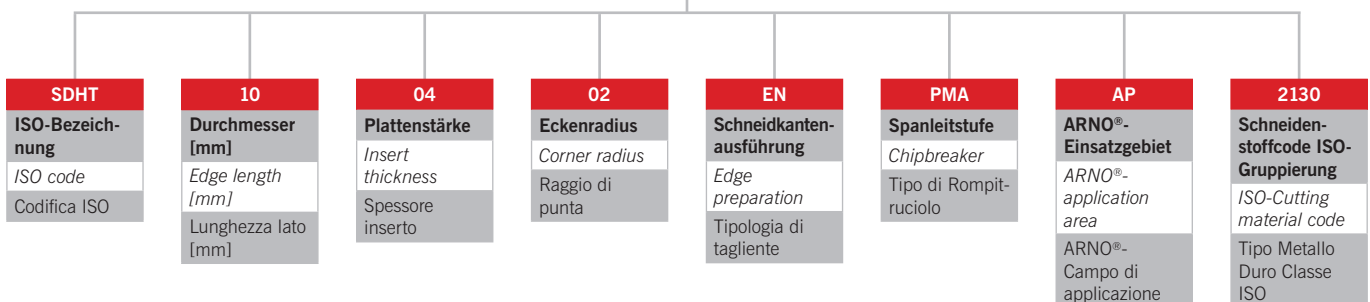



2

Eckfräsen / *Square shoulder* / *Fresatura a Spallamento Retto*

Aufsteckfräser / *Shell mill cutters* / *Fresa a manicotto*

Seite / Page / Pagina **50 – 51**

Schaftfräser / *Cylindrical shank* / *Codolo cilindrico*

Seite / Page / Pagina **52**

Einschraubfräser / *Screw shank cutters* / *Fresa con attacco filettato*

Seite / Page / Pagina **52**

HFC-Fräsen / *HFC-milling* / *HFC-Fresatura ad alto avanzamento*

Aufsteckfräser / *Shell mill cutters* / *Fresa a manicotto*

Seite / Page / Pagina **53 – 54**

Schaftfräser / *Cylindrical shank* / *Codolo cilindrico*

Seite / Page / Pagina **55**

Einschraubfräser / *Screw shank cutters* / *Fresa con attacco filettato*

Seite / Page / Pagina **55**



Eckfräsen

Square shoulder / *Fresatura a Spallamento Retto*

Wendescheidplatten / *Indexable inserts* / *Inserti*

Seite / Page / Pagina **60 – 61**



HFC-Fräsen

HFC-milling / *HFC-Fresatura ad alto avanzamento*

Wendescheidplatten / *Indexable inserts* / *Inserti*

Seite / Page / Pagina **62 – 63**

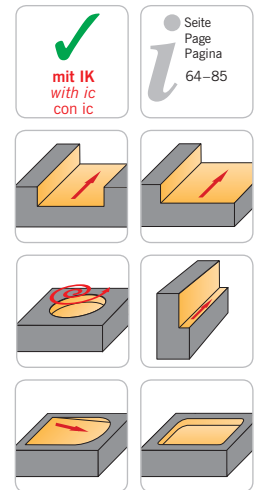
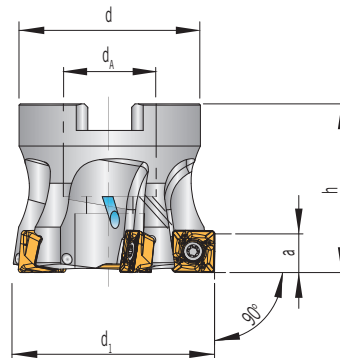

Eckfräser / Square shoulder cutter / Frese per spallamenti – Duo-Mill -10

Bezeichnung Designation Articolo	d ₁	d _A	h	d	a	z	Wendeschneidplatte Indexable insert Inserto
FDA-190.040.R04-10 *	40	16	40	35	9	4	SD.. 10...
FDA-190.040.R06-10 *	40	16	40	35	9	6	SD.. 10...
FDA-190.050.R05-10	50	22	40	43	9	5	SD.. 10...
FDA-190.050.R06-10	50	22	40	43	9	6	SD.. 10...
FDA-190.050.R07-10	50	22	40	48	9	7	SD.. 10...
FDA-190.052.R04-10	52	22	40	43	9	4	SD.. 10...
FDA-190.052.R06-10	52	22	40	43	9	6	SD.. 10...
FDA-190.063.R06-10	63	22	40	48	9	6	SD.. 10...
FDA-190.063.R08-10	63	22	40	48	9	8	SD.. 10...
FDA-190.066.R04-10	66	22	40	48	9	4	SD.. 10...
FDA-190.066.R06-10	66	22	40	40	9	6	SD.. 10...
FDA-190.080.R08-10	80	27	50	60	9	8	SD.. 10...
FDA-190.100.R10-10	100	32	50	78	9	10	SD.. 10...
FDA-190.125.R12-10	125	40	60	90	9	12	SD.. 10...
FDA-190.160.R14-10**	160	40	60	104	9	14	SD.. 10...

* mit Powerschraube AS 0047 (siehe Seite 65)
 * with powerscrew AS 0047 (see page 65)
 * con vite per manicotto AS 0047 (vedi pag. 65)

** ohne Innenkühlung
 ** without internal coolant
 ** senza adduzione interna

Hinweis: Passende Wendeschneidplatten finden Sie ab Seite 60, Spannmittel auf Seite 64.
 Remark: Indexable inserts you find from page 60, face mill adaptors on page 64.
 Nota: Inserti a fissaggio meccanico da pag. 60, mandrini di fresatura a pag. 64.

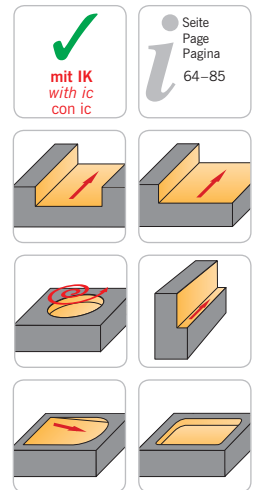
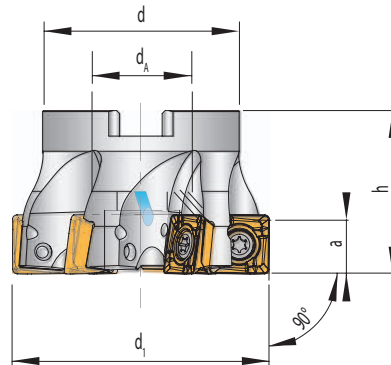

Eckfräser / Square shoulder cutter / Frese per spallamenti – Duo-Mill -15

Bezeichnung Designation Articolo	d ₁	d _A	h	d	a	z	Wendeschneidplatte Indexable insert Inserto
FDA-190.050.R05-15	50	22	40	48	13,5	5	SD.. 15...
FDA-190.052.R03-15	52	22	40	48	13,5	3	SD.. 15...
FDA-190.063.R04-15	63	22	40	48	13,5	4	SD.. 15...
FDA-190.063.R06-15	63	22	40	48	13,5	6	SD.. 15...
FDA-190.066.R04-15	66	22	40	48	13,5	4	SD.. 15...
FDA-190.080.R07-15	80	27	50	67	13,5	7	SD.. 15...
FDA-190.085.R07-15	85	27	50	60	13,5	7	SD.. 15...
FDA-190.100.R09-15	100	32	50	86	13,5	9	SD.. 15...
FDA-190.125.R11-15	125	40	60	104	13,5	11	SD.. 15...
FDA-190.160.R12-15*	160	40	60	104	13,5	12	SD.. 15...

* ohne Innenkühlung
* without internal coolant
* senza adduzione interna

Hinweis: Passende Wendeschneidplatten finden Sie ab Seite 61, Spannmittel auf Seite 64.

Remark: Indexable inserts you find from page 61, face mill adaptors on page 64.

Nota: Inserti a fissaggio meccanico da pag. 61, mandrini di fresatura a pag. 64.

2

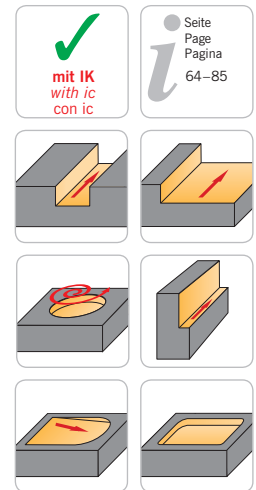
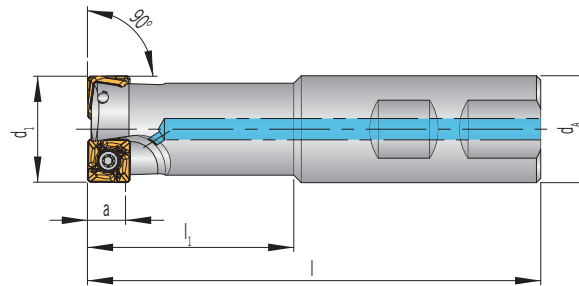

Eckfräser / Square shoulder cutter / Frese per spallamenti – Duo-Mill -10

Bezeichnung Designation Articolo	d ₁	d _A	l	l ₁	a	z	Wendeschneidplatte Indexable insert Inserto
FDC-190.025.R02-10	25	25	106	48	9	2	SD.. 10...
FDC-190.025.R03-10	25	25	106	48	9	3	SD.. 10...
FDC-190.032.R03-10	32	32	124	62	9	3	SD.. 10...
FDC-190.032.R04-10	32	32	124	62	9	4	SD.. 10...

Hinweis: Passende Wendeschneidplatten finden Sie ab Seite 60, Spannmittel auf Seite 64.

Remark: Indexable inserts you find from page 60, face mill adaptors on page 64.

Nota: Inserti a fissaggio meccanico da pag. 60, mandrini di fresatura a pag. 64.

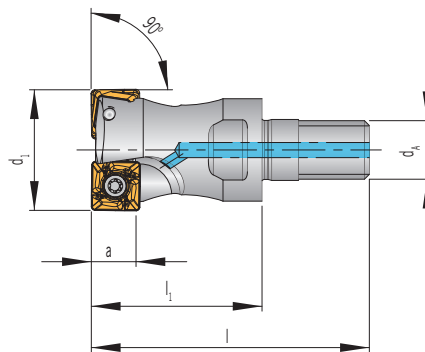
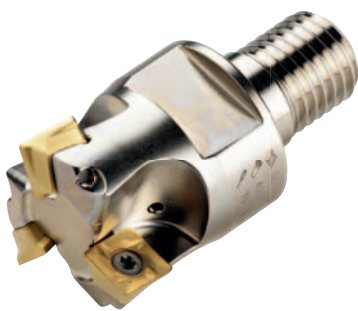
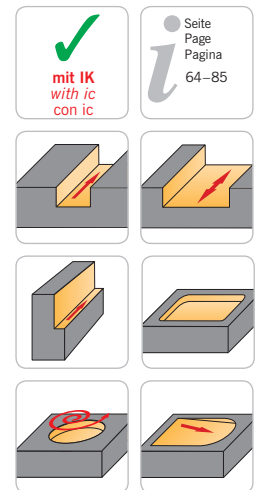

Eckfräser / Square shoulder cutter / Frese per spallamenti – Duo-Mill -10

Bezeichnung Designation Articolo	d ₁	d _A	l	l ₁	a	z	Wendeschneidplatte Indexable insert Inserto
FDG-190.025.R02-10	25	M12	57	35	9	2	SD.. 10...
FDG-190.025.R03-10	25	M12	57	35	9	3	SD.. 10...
FDG-190.032.R03-10	32	M16	58	35	9	3	SD.. 10...
FDG-190.032.R04-10	32	M16	58	35	9	4	SD.. 10...
FDG-190.035.R04-10	35	M16	58	35	9	4	SD.. 10...
FDG-190.040.R04-10	40	M16	58	35	9	4	SD.. 10...
FDG-190.042.R04-10	42	M16	58	35	9	4	SD.. 10...

Hinweis: Passende Wendeschneidplatten finden ab der Seite 60, Spannmittel auf Seite 64.

Remark: Indexable inserts you find from page 60, face mill adaptors on page 64.

Nota: Inserti a fissaggio meccanico da pag. 60, mandrini di fresatura a pag. 64.

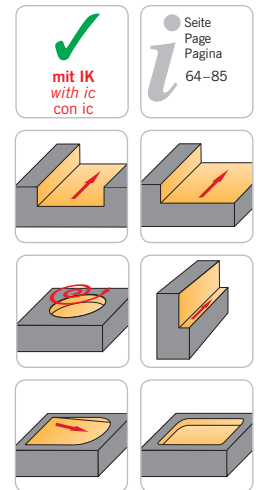
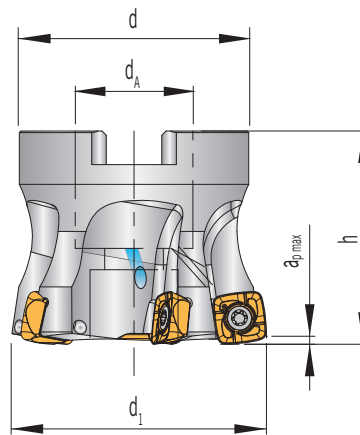

HFC-Fräser / HFC-milling cutter / HFC-Fresatura – Duo-Mill -10

Bezeichnung Designation Articolo	d ₁	d _A	h	d	a _{p max}	z	Wendeschneidplatte Indexable insert Inserto
FDA-190.040.R04-10 *	40	16	40	35	1,5	4	SD.. 10...
FDA-190.040.R06-10 *	40	16	40	35	1,5	6	SD.. 10...
FDA-190.050.R05-10	50	22	40	43	1,5	5	SD.. 10...
FDA-190.050.R06-10	50	22	40	43	1,5	6	SD.. 10...
FDA-190.050.R07-10	50	22	40	48	1,5	7	SD.. 10...
FDA-190.052.R04-10	52	22	40	43	1,5	4	SD.. 10...
FDA-190.052.R06-10	52	22	40	43	1,5	6	SD.. 10...
FDA-190.063.R06-10	63	22	40	48	1,5	6	SD.. 10...
FDA-190.063.R08-10	63	22	40	48	1,5	8	SD.. 10...
FDA-190.066.R04-10	66	22	40	48	1,5	4	SD.. 10...
FDA-190.066.R06-10	66	22	40	40	1,5	6	SD.. 10...
FDA-190.080.R08-10	80	27	50	60	1,5	8	SD.. 10...
FDA-190.100.R10-10	100	32	50	78	1,5	10	SD.. 10...
FDA-190.125.R12-10	125	40	60	90	1,5	12	SD.. 10...
FDA-190.160.R14-10**	160	40	60	104	1,5	14	SD.. 10...

* mit Powerschraube AS 0047 (siehe Seite 65)
 * with powerscrew AS 0047 (see page 65)
 * con vite per manicotto AS 0047 (vedi pag. 65)

** ohne Innenkühlung
 ** without internal coolant
 ** senza adduzione interna

Hinweis: Passende Wendeschneidplatten finden Sie ab Seite 62, Spannmittel auf Seite 64.
 Remark: Indexable inserts you find from page 62, face mill adaptors on page 64.
 Nota: Inserti a fissaggio meccanico da pag. 62, mandrini di fresatura a pag. 64.

2

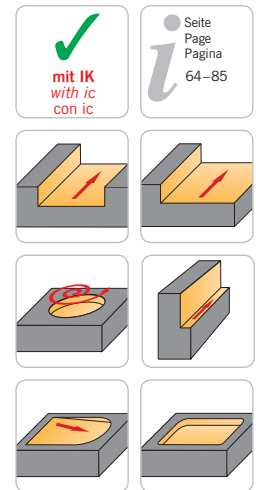
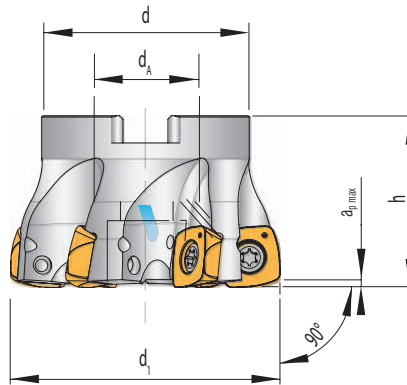

HFC-Fräser / HFC-milling cutter / HFC-Fresatura – Duo-Mill -15

Bezeichnung Designation Articolo	d ₁	d _A	h	d	a _{p max}	z	Wendeschneidplatte Indexable insert Inserto
FDA-190.050.R05-15	50	22	40	48	2,5	5	SD.. 15...
FDA-190.052.R03-15	52	22	40	48	2,5	3	SD.. 15...
FDA-190.063.R04-15	63	22	40	48	2,5	4	SD.. 15...
FDA-190.063.R06-15	63	22	40	48	2,5	6	SD.. 15...
FDA-190.066.R04-15	66	22	40	48	2,5	4	SD.. 15...
FDA-190.080.R07-15	80	27	50	67	2,5	7	SD.. 15...
FDA-190.085.R07-15	85	27	50	60	2,5	7	SD.. 15...
FDA-190.100.R09-15	100	32	50	86	2,5	9	SD.. 15...
FDA-190.125.R11-15	125	40	60	104	2,5	11	SD.. 15...
FDA-190.160.R12-15**	160	40	60	104	2,5	12	SD.. 15...

* ohne Innenkühlung
* without internal coolant
* senza adduzione interna

Hinweis: Passende Wendeschneidplatten finden Sie ab Seite 63, Spannmittel auf Seite 64.

Remark: Indexable inserts you find from page 63, face mill adaptors on page 64.

Nota: Inserti a fissaggio meccanico da pag. 63, mandrini di fresatura a pag. 64.

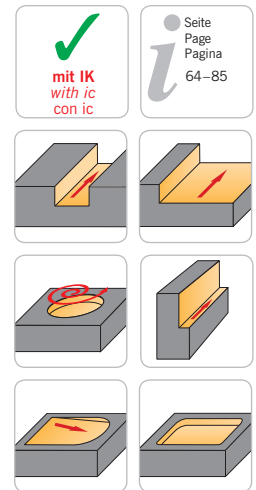
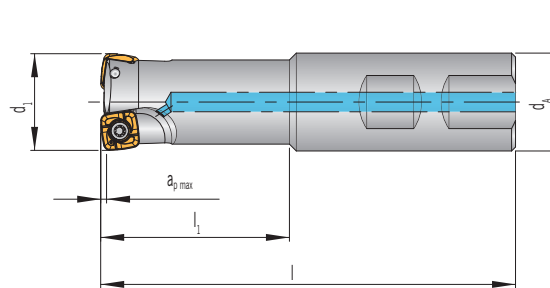

HFC-Fräser / HFC-milling cutter / HFC-Fresatura – Duo-Mill -10

Bezeichnung Designation Articolo	d ₁	d _A	l	l ₁	a _{p max}	z	Wendeschneidplatte Indexable insert Inserto
FDC-190.025.R02-10	25	25	106	47	1,5	2	SD.. 10...
FDC-190.025.R03-10	25	25	106	47	1,5	3	SD.. 10...
FDC-190.032.R03-10	32	32	124	61	1,5	3	SD.. 10...
FDC-190.032.R04-10	32	32	124	61	1,5	4	SD.. 10...

Hinweis: Passende Wendeschneidplatten finden Sie ab Seite 62, Spannmittel auf Seite 64.

Remark: Indexable inserts you find from page 62, face mill adaptors on page 64.

Nota: Inserti a fissaggio meccanico da pag. 62, mandrini di fresatura a pag. 64.

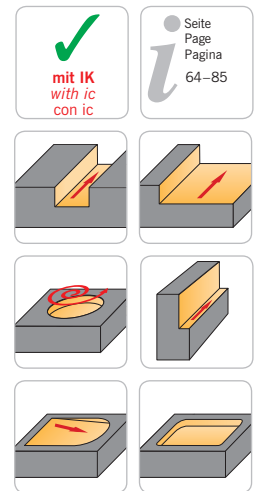
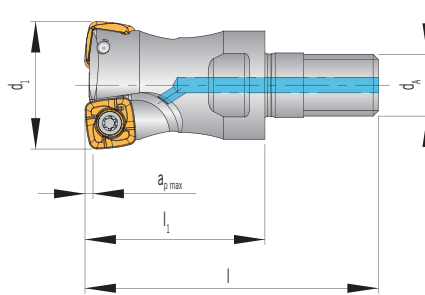
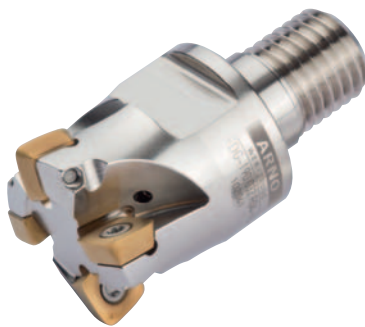

HFC-Fräser / HFC-milling cutter / HFC-Fresatura – Duo-Mill -10

Bezeichnung Designation Articolo	d ₁	d _A	l	l ₁	a _{p max}	z	Wendeschneidplatte Indexable insert Inserto
FDG-190.025.R02-10	25	M12	57	35	1,5	2	SD.. 10...
FDG-190.025.R03-10	25	M12	57	35	1,5	3	SD.. 10...
FDG-190.032.R03-10	32	M16	58	35	1,5	3	SD.. 10...
FDG-190.032.R04-10	32	M16	58	35	1,5	4	SD.. 10...
FDG-190.035.R04-10	35	M16	58	35	1,5	4	SD.. 10...
FDG-190.040.R04-10	40	M16	58	35	1,5	4	SD.. 10...
FDG-190.042.R04-10	42	M16	58	35	1,5	4	SD.. 10...

Hinweis: Passende Wendeschneidplatten finden Sie ab Seite 62, Spannmittel auf Seite 64.

Remark: Indexable inserts you find from page 62, face mill adaptors on page 64.

Nota: Inserti a fissaggio meccanico da pag. 62, mandrini di fresatura a pag. 64.

2

- PMA

Für die Zerspanung von Aluminium und NE-Metallen.



- PMA

For machining aluminium, aluminium alloys and non-ferrous materials.

Schlicht- bis Schrupperzspanung

Finishing to roughing
Finitura e sgrossatura

einseitig
single sided
singolo lato



- PMA

Per la lavorazione di alluminio e materiali non ferrosi.

- PMG

Geometrie für die Zerspanung von Gusswerkstoffen.



- PMG

Geometry for machining cast materials.

Mittlere bis grobe Zerspanung

Medium to rough cutting
Sgrossatura da media a pesante

einseitig
single sided
singolo lato



- PMG

Geometria per la lavorazione di ghisa.

- PMR

Zur Bearbeitung rostfreier Stähle.



- PMR

For machining stainless steels.

Mittlere bis grobe Zerspanung

Medium to rough cutting
Sgrossatura da media a pesante

einseitig
single sided
singolo lato



- PMR

Per la lavorazione di acciaio inox.

- PMS

Geometrie für die Stahlbearbeitung.



- PMS

Geometry for machining steel.

Mittlere bis grobe Zerspanung

Medium to rough cutting
Sgrossatura da media a pesante

einseitig
single sided
singolo lato



- PMS

Geometria per la lavorazione di acciai.

Geometry description – HFC-milling

Descrizione delle Geometrie – HFC-Fresatura ad alto avanzamento

- PSR

Zur Bearbeitung rostfreier Stähle.



- PSR

For machining stainless steels.

Mittlere bis grobe Zerspanung
 Medium to rough cutting
 Sgrossatura da media a pesante

einseitig
 single sided
 singolo lato



- PSR

Per la lavorazione di acciaio inox.

- PSS

Geometrie für die Stahlbearbeitung.



- PSS

Geometry for machining steel.

Schlicht- und mittlere Zerspanung
 Finishing and medium machining
 Finitura e medie asportazioni

einseitig
 single sided
 singolo lato



- PSS

Geometria per la lavorazione di acciai.

2

Hartmetall beschichtet / Carbide grade coated / Metallo duro rivestito**AK5315**

PVD-beschichtete Hartmetallsorte mit einer TiAlN-Beschichtung. Der Hauptanwendungsbereich dieser Sorte ist die Fräsbearbeitung von Gusswerkstoffen (GG und GGG).

PVD coated (TiAlN) carbide insert. The main application area for this grade is cast iron (GG and GGG).

Inserto con rivestimento PVD (TiAlN). Qualità specifica per la fresatura di Ghise grigie e Sferoidali (GG e GGG).

AM5740

PVD-beschichtete Hartmetallsorte mit einer AlTiN-Mehrlagenbeschichtung. Hauptanwendung rostfreier Stahl. Allroundsorte für die moderne Bearbeitung, die eine gute Ausgewogenheit in Bezug auf die Bearbeitungssicherheit und Produktivität bietet.

PVD coated (AlTiN multilayer) carbide insert. Main application stainless steel. For milling stainless steel at medium to high cutting speeds, also suitable for milling high temperature alloys and titanium alloys.

Inserto con rivestimento multistrato (AlTiN) PVD. Prima scelta per lavorazione di acciai inossidabili. Per la fresatura di acciaio inossidabile a velocità di taglio da medie ad alte, adatto anche per la fresatura di leghe resistenti al calore o leghe di titanio.

AP5215

PVD-Mehrlagenbeschichtung Hauptanwendung NE-Metalle. Universelle Sorte zur Schlichtbearbeitung von Gusswerkstoffen, Stahl und rostfreien Stählen. Auch sehr gut geeignet für die Feinbearbeitung von exotischen Werkstoffen.

PVD-multilayer coating Main application non ferrous materials. Light machining of exotic materials. Finishing of cast materials, steel and stainless steel.

Rivestimento PVD-multistrato Utilizzo principale per lavorazione di materiali non metallici. Ottima per la superfinitura di ghisa, acciai e acciai inossidabili. Qualità utilizzabile anche per finitura di materiali esotici.

AP5330

PVD-beschichtete Hartmetallsorte mit einer TiAlN-Beschichtung. Allroundsorte für die moderne Bearbeitung, die eine gute Ausgewogenheit in Bezug auf die Bearbeitungssicherheit und Produktivität bietet.

PVD coated (TiAlN) carbide insert. Universal grade for the modern production where machine reliability and high productivity is essential. Main application area is steel.

Inserto con rivestimento multistrato (TiAlN) PVD. Grado universale per la moderna produzione dove sono essenziali affidabilità e produttività. Qualità specifica per acciaio.

AP5430

PVD-beschichtete Hartmetallsorte mit einer TiAlN-Beschichtung + TiN-Zusatzbeschichtung. Allroundsorte für die Fräsbearbeitung sämtlicher Stahlwerkstoffe. Substrat mit guter Zähigkeitreserve in Kombination mit hoher Verschleißfestigkeit.

PVD coated (TiAlN/TiN) carbide insert. General purpose grade for all steel machining, tough yet wear resistant. TiN coating for easier wear recognition.

Inserto con rivestimento multistrato (TiAlN/TiN) PVD. Grado per acciaio, tenace e allo stesso tempo resistente all'usura. Rivestimento Tin per un miglior riconoscimento dell'usura.

AP5830+

PVD-beschichtete Hartmetallsorte. Besonders geeignet zum Nassfräsen von Stählen, rostfreien Werkstoffen und Gusswerkstoffen. Eine universell einsetzbare Sorte gegen Kammrisssbildung.

PVD-carbide grade. Especially suitable for wet milling of steel, stainless steel and cast materials. A universal grade, very resistant to thermal cracking.

Metallo duro rivestito PVD. Qualità studiata appositamente per lavorazioni con refrigerante di acciaio, acciaio inossidabile e acciai stampati o da fusione. Un grado universale, molto resistente a shock termici.

Hartmetall unbeschichtet / Carbide grade uncoated / Metallo duro non rivestito**AN1015**

Unbeschichtete Hartmetallsorte. Sorte zur Bearbeitung von Aluminium und NE-Metallen. Zur Reduzierung der Aufbauschneidenbildung ist die Spanfläche hochglanzpoliert.

Uncoated carbide inserts. For milling aluminium and non-ferrous materials. Insert is polished to reduce build up edge.

Metallo duro non rivestito. Qualità di metallo duro specifica per la lavorazione di materiali non ferrosi. Ridotte forze di taglio grazie ad un tagliente affilato e ad una superficie dell'inserto lappata.

2

Hartmetall beschichtet / Carbide grade coated / Metallo duro rivestito**AM5740**

PVD-beschichtete Hartmetallsorte mit einer AlTiN-Mehrlagenbeschichtung.
Zum Fräsen von rostfreien Stählen bei mittleren und hohen Schnittgeschwindigkeiten. Nebenwendung zum Fräsen warmfester Legierungen und Titanlegierungen.

PVD coated (AlTiN multilayer) carbide insert. For milling stainless steel at medium to high cutting speeds, also suitable for milling high temperature alloys and titanium alloys.

Inserto con rivestimento multistrato (AlTiN) PVD.
Per la fresatura di acciaio inossidabile a velocità di taglio da medie ad alte, adatto anche per la fresatura di leghe resistenti al calore o leghe di titanio.

AP5325

PVD-beschichtete Hartmetallsorte mit einer TiAlN-Beschichtung.
Zum Fräsen von allgemeinen Stählen für die Schlicht- und Schruppbearbeitung bei mittleren bis hohen Schnittgeschwindigkeiten.

PVD coated (TiAlN) carbide insert. For general milling of steel. Roughing and finishing at medium to high cutting speeds.

Inserto con rivestimento multistrato (TiAlN) PVD.
Qualità specifica per acciaio. Sgrossatura e finitura a velocità medie ed elevate.

AP5335

PVD-beschichtete Hartmetallsorte für die Zerspanung von Stahl mit hoher Zähigkeit im Substrat.
Geringe Neigung zu Schneidkantenausbrüchen.

Very tough PVD coated grade for machining steel. High resistance to cutting edge breakage.

Grado molto tenace con rivestimento PVD.
Per la lavorazione di acciaio. Alta resistenza contro le scheggiature.

AP5340

PVD-beschichtete Hartmetallsorte mit einer TiAlN-Beschichtung.
Erste Wahl für instabile Bedingungen. Kann auch als Unterstützungssorte bei zähigkeitsfordernden Operationen eingesetzt werden.

PVD coated (TiAlN) carbide insert. Preferred choice for unstable conditions. Can also be used where extreme toughness is required.

Inserto con rivestimento multistrato (TiAlN) PVD.
Qualità per condizioni instabili di lavorazione. Può essere usato anche dove è necessaria massima tenacità.

AP5440

PVD-beschichtete Hartmetallsorte mit einer TiAlN-Beschichtung + TiN-Zusatzbeschichtung.
Erste Wahl bei instabilen Bedingungen, längeren Auskraglängen und niedrigen bis mittleren Schnittgeschwindigkeiten.

PVD coated (TiAlN/TiN) carbide insert. Preferred choice for unstable conditions, long overhang and medium to low cutting speeds.

Inserto con rivestimento multistrato (TiAlN/TiN) PVD.
Da preferire per condizioni di lavoro instabili e velocità medio-basse.

AP5830+

PVD-beschichtete Hartmetallsorte.
Besonders geeignet zum Nassfräsen von Stählen, rostfreien Werkstoffen und Gusswerkstoffen. Eine universell einsetzbare Sorte gegen Kammrisbildung.

PVD coated carbide grade. Especially suitable for wet milling of steel, stainless steel and cast materials. A universal grade, very resistant to thermal cracking.

Metallo duro rivestito PVD.
Qualità studiata appositamente per lavorazioni con refrigerante di acciaio, acciaio inossidabile e acciai stampati o da fusione. Un grado universale, molto resistente a shock termici.

Indexable inserts – Square shoulder
 Inserti – Fresatura a Spallamento Retto

Duo-Mill -10

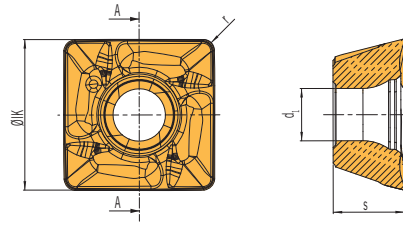

2



Bezeichnung Designation Articolo	IK	s	d ₁	r	beschichtet coated rivestito						unbeschichtet uncoated non rivestito	
					AK5315	AM5740	AP5215	AP5330	AP5430	AP5830+	AN1015	
SDHT 100402FN-PMA	10,1	4,76	3,5	0,2			●					●
SDHT 100404FN-PMA	10,1	4,76	3,5	0,4								●
SDHT 100408FN-PMA	10,1	4,76	3,5	0,8			●					●
SDMT 100408EN-PMG	10,1	4,76	3,5	0,8	●							
SDMT 100408EN-PMR	10,1	4,76	3,5	0,8		●						
SDMT 100408EN-PMS	10,1	4,76	3,5	0,8				●	●	●		

● Hauptanwendung
Main application
Applicazione principale

○ Nebenanwendung
Secondary application
Applicazione secondaria

P			○	●	●	●
M		●	○			●
K	●		○			●
N			●			●
S		●	○			
H						

Duo-Mill -15

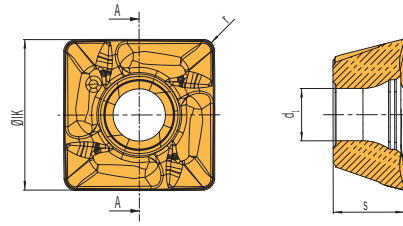

Bezeichnung Designation Articolo	IK	s	d ₁	r	beschichtet coated rivestito						unbeschichtet uncoated non rivestito	
					AK5315	AM5740	AP5215	AP5330	AP5430	AP5830+	AN1015	
SDHT 155012FN-PMA	14,7	5	5,5	1,2								●
SDMT 155012EN-PMG	14,7	5	5,5	1,2	●							
SDMT 155012EN-PMR	14,7	5	5,5	1,2		●						
SDMT 155012EN-PMS	14,7	5	5,5	1,2				●	●	●		

- Hauptanwendung
Main application
Applicazione principale
- Nebenanwendung
Secondary application
Applicazione secondaria

P			○	●	●	●
M		●	○			●
K	●		○			●
N			●			●
S		●	○			
H						



Duo-Mill -10

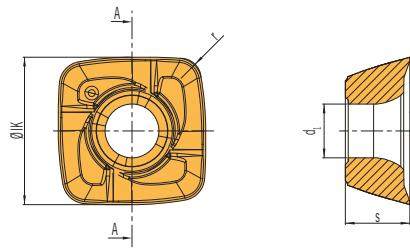

2



Bezeichnung Designation Articolo	IK	s	d ₁	r	AM5740	AP5325	AP5335	AP5340	AP5440	AP5830+
SDMT 100415SN-PSS	9,6	4,20	3,5	1,5		●	●			●
SDMW 100415SN-PSS	9,6	4,20	3,5	1,5				●		
SDMW 100415SN-PSS	9,6	4,20	3,5	1,5					●	
SDMT 100415SN-PSR	9,6	4,20	3,5	1,5	●					

- Hauptanwendung
Main application
Applicazione principale
- Nebenanwendung
Secondary application
Applicazione secondaria

P		●	●	●	●	●
M	●					●
K		○				●
N						
S	○					
H						

Duo-Mill -15

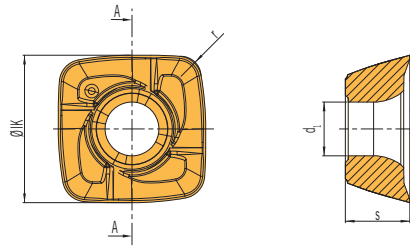

Bezeichnung Designation Articolo	IK	s	d ₁	r	AM5740	AP5325	AP5335	AP5340	AP5440	AP5830+
SDMT 155020SN-PSS	14,2	5	5,5	2		●			●	
SDMW 155020SN-PSS	14,2	5	5,5	2				●		
SDMW 155020SN-PSS	14,2	5	5,5	2						●
SDMT 155020SN-PSR	14,2	5	5,5	2	●					

- Hauptanwendung
Main application
Applicazione principale
- Nebenanwendung
Secondary application
Applicazione secondaria

P		●	●	●	●	●
M	●					●
K		○				●
N						
S	○					
H						

2

Werkzeugaufnahme SK40 für Duo-Mill Fräser

SK40 face mill adaptors for Duo-Mill cutters / Attacchi SK40 per Frese

Fräser-Ø Cutter-Ø Fresatura-Ø	L	Werkzeugaufnahme Adaptor Attacco SK40 DIN 69871	Werkzeugaufnahme Adaptor Attacco SK40 MAS BT
[mm]	[mm]	Bezeichnung Designation Articolo	Bezeichnung Designation Articolo
40	40	69871AD+B-40-16x35IK-L40	BT40AD+B-16x35IK-L40
50	40	69871AD+B-40-22x43IK-L40	BT40AD+B-22x43IK-L40
63	40	69871AD+B-40-22x48IK-L40	BT40AD+B-22x48IK-L40
80	50	69871AD+B-40-27x60IK-L50	BT40AD+B-27x60IK-L50
100	50	69871AD+B-40-32x78IK-L50	BT40AD+B-32x78IK-L50
125	50	69871AD+B-40-40x90IK-L50	BT40AD+B-40x90IK-L50
160	50	69871AD+B-40-40x104IK-L50	BT40AD+B-40x104IK-L50

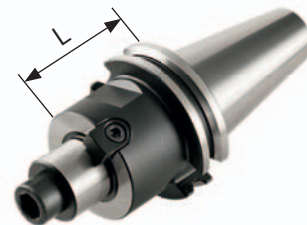

2

Werkzeugaufnahme HSK63 für Duo-Mill Fräser

HSK63 face mill adaptors for Duo-Mill cutters / Attacchi HSK63 per Frese

Fräser-Ø Cutter-Ø Fresatura-Ø	L	Werkzeugaufnahme Adaptor Attacco SK40 DIN 69871
[mm]	[mm]	Bezeichnung Designation Articolo
40	40	HSK-A63-16x35IK-L40
50	40	HSK-A63-22x43IK-L40
63	40	HSK-A63-22x48IK-L40
80	55	HSK-A63-27x60IK-L55
100	60	HSK-A63-32x78IK-L60
125	60	HSK-A63-40x90IK-L60
160	60	HSK-A63-40x104IK-L60



Werkzeugaufnahme SK40 für Duo-Mill Fräser

SK40 face mill adaptors for Duo-Mill cutters / Attacchi SK40 per Frese

Fräser-Ø Cutter-Ø Fresatura-Ø	L	Werkzeugaufnahme Adaptor Attacco
[mm]	[mm]	Bezeichnung Designation Articolo
25	69	69871AD-40-M12-21x50IK-L69
25	119	69871AD-40-M12-21x100IK-L119
32-42	69	69871AD-40-M16-29x50IK-L69
32-42	119	69871AD-40-M16-29x100IK-L119

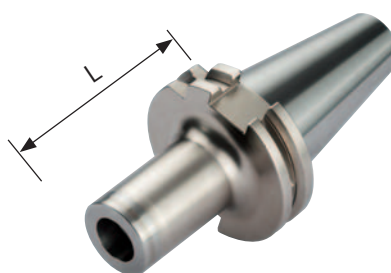

Werkzeugaufnahme HSK63 für Duo-Mill Fräser

HSK63 face mill adaptors for Duo-Mill cutters / Attacchi HSK63 per Frese

Fräser-Ø Cutter-Ø Fresatura-Ø	L	Werkzeugaufnahme Adaptor Attacco
[mm]	[mm]	Bezeichnung Designation Articolo
25	76	HSK-A63-M12-21x50IK-L76
25	126	HSK-A63-M12-21x100IK-L126
32-42	76	HSK-A63-M16-29x50IK-L76
32-42	126	HSK-A63-M16-29x100IK-L126

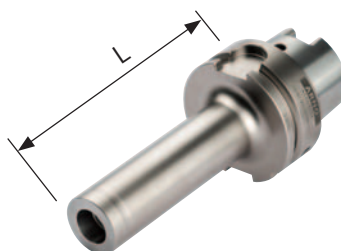

Schrauben und Schraubendreher

Screws and Screwdrivers

Chiavi e Viti

Bezeichnung Designation Articolo	Drehmoment Torque Forza di serraggio	TorxPlus®-Spannschraube TorxPlus®-Screw TorxPlus®-Vite	TorxPlus®-Schlüssel TorxPlus®-Key TorxPlus®-Chiave
Duo-Mill -10	3 Nm	AS 0042	(T5110 IP)
Duo-Mill FDA190-040... -10	-	AS 0047*	Imbus 4 mm
Duo-Mill -15	5 Nm	AS 0046	(T5120 IP)

* Powerschraube L/R M8x29

* Powerscrew L/R M8x29

* Vite a doppio principio L/R M8x29

HINWEIS TROCKENBEARBEITUNG:

Es kann zur erhöhten Wärmeentwicklung des Trägers bzw. der Schrauben führen.

- Bitte rechtzeitig einen Schraubenwechsel durchführen
- Bei erhitztem Werkzeug keinen Plattenwechsel vornehmen, abkühlen lassen, ggf. mit Schwesterwerkzeug arbeiten
- Schraubenwechsel nur mit IP-Schlüssel bzw. Drehmomentschlüssel durchführen

INFO DRY MACHINING:

Can lead to increased temperature to the tool and the screws.

- Please change screws accordingly.
- Please do not replace inserts while the holder is hot. Either leave tool to cool down or work with similar sister tooling.
- Use torx plus and torque screwdriver when replacing insert screws.

NOTA LAVORAZIONE A SECCO:

Si possono riscontrare elevate temperatura sull'inserto, vite e corpo fresa:

- Non sostituire inserti e viti mentre il corpo utensile è caldo. Lasciare raffreddare l'utensile.
- Utilizzare chiave dinamometrica quando si sostituiscono le viti
- prevedere una sostituzione delle viti appropriata



Hinweis: Drehmoment-Schraubendreher siehe Seite 289.

Remark: For torque screwdrivers see page 289.

Nota: Chiavi dinamometriche a pagina 289.

Duo-Mill -10 – Schnittdatenrichtwerte Eckfräsen mit SD..100408...

ISO	Werkstoff	Brinell-Härte HB	Schnittgeschwindigkeit V _c [m/min]						
			AK5315	AM5740	AP5215	AP5330	AP5430	AP5830+	AN1015
P	Unlegierter Stahl und Stahlguss	< 0,15 % C / vergütet				100–220	100–220	100–220	
		0,15–0,45 % C / vergütet	125			100–220	100–220	100–220	
		> 0,45 % C / vergütet	150–250			100–220	100–220	100–220	
	Niedrig legierter Stahl und Stahlguss	gegült	300			80–220	80–220	80–220	
		vergütet	180			80–220	80–220	80–220	
		vergütet	250–300			80–220	80–220	80–220	
Hochlegierter Stahl, hochlegierter Werkzeugstahl und Stahlguss	gegült	200			80–180	80–180	80–180		
	vergütet	350			80–180	80–180	80–180		
Nichtrostender Stahl und Stahlguss	ferritisch, gegült	200			70–180	70–180	70–180		
	martensitisch, vergütet	325			70–180	70–180	70–180		
M	Nichtrostender Stahl	ferritisch, martensitisch gegült	200	60–200					
		austenitisch, abgeschreckt	180	60–200					
		Duplex, abgeschreckt	230	60–200					
		martensitisch/austenitisch, abgeschreckt	330	60–200					
K	Grauguss	perlitisches/ferritisch	180	180–350					
		perlitisches/martensitisch	260	140–280					
	Gusseisen mit Kugelgraphit	ferritisch	160	130–250					
		perlitisches	–	100–200					
Temperguss	ferritisch	130	150–320						
	perlitisches	230	120–250						
N	Aluminium-Knetlegierungen	nicht aushärtbar	60		440–1500			400–1500	
		aushärtbar, ausgehärtet	100		440–1500			400–1500	
	Aluminium-Gusslegierungen	≤ 12 % Si, ausgehärtet	80		440–1500			400–1500	
		≤ 12 % Si, aushärtbar, ausgehärtet	90		330–1200			300–1200	
		≤ 12 % Si, nicht aushärtbar	130		220–1000			200–1000	
	Kupfer und Kupferlegierungen (Bronze / Messing)	Automatenlegierung, Pb > 1%	–		220–600			200–600	
		Messing, Rotguss	–		275–1000			250–1000	
		Aluminiumbronze	90		165–400			150–400	
Kupfer und Elektrolytkupfer		100		330–800			300–800		
Nichtmetallische Werkstoffe	Duroplaste	100		90–1000			80–1000		
	Faserverstärkte Kunststoffe	–		85–500			75–500		
	Hartgummi	–		90–300			80–300		
S	Warmfeste Legierungen	Fe-Basis, gegült	200	20–60					
		Fe-Basis, ausgehärtet	280	20–60					
		Ni- oder Co-Basis, gegült	250	20–60					
		Ni- oder Co-Basis 30–58 HRC, gegossen	–	20–30					
		Ni- oder Co-Basis 1500–2200 Nmm ² , ausgehärtet	–	20–30					
Titanlegierungen, Alpha+Beta-Legierungen	Rein-Titan	Rm 440	40–70						
	ausgehärtet	Rm 1050	20–40						
H	Gehärteter Stahl	gehärtet und angelassen	55 HRC						
		gehärtet und angelassen	60 HRC						
	Hartguss	gegossen	400						
Gehärtetes Gusseisen	gehärtet und angelassen	55 HRC							

Die Tabellenwerte sind Richtwerte. Es kann notwendig sein, die Werte den jeweiligen Bearbeitungsumständen anzupassen.

Duo-Mill -15 – Schnittdatenrichtwerte Eckfräsen mit SD..155012...

ISO	Werkstoff		Brinell-Härte HB	Schnittgeschwindigkeit V _c [m/min]						
				AK5315	AM5740	AP5215	AP5330	AP5430	AP5830+	AN1015
P	Unlegierter Stahl und Stahlguss	< 0,15 % C / vergütet	125				100–220	100–220	100–220	
		0,15–0,45 % C / vergütet	150–250				100–220	100–220	100–220	
		> 0,45 % C / vergütet	300				100–220	100–220	100–220	
	Niedrig legierter Stahl und Stahlguss	geglüht	180				80–220	80–220	80–220	
		vergütet	250–300				80–220	80–220	80–220	
		vergütet	350				80–220	80–220	80–220	
	Hochlegierter Stahl, hochlegierter Werkzeugstahl und Stahlguss	geglüht	200				80–220	80–220	80–220	
vergütet		350				80–220	80–220	80–220		
Nichtrostender Stahl und Stahlguss	ferritisch, geglüht	200				70–180	70–180	70–180		
	martensitisch, vergütet	325				70–180	70–180	70–180		
M	Nichtrostender Stahl	ferritisch, martensitisch geglüht	200		60–200					
		austenitisch, abgeschreckt	180		60–200					
		Duplex, abgeschreckt	230		60–200					
		martensitisch/austenitisch, ausgehärtet	330		60–200					
K	Grauguss	perlitisches/ferritisch	180	180–350						
		perlitisches/martensitisch	260	140–280						
	Gusseisen mit Kugelgraphit	ferritisch	160	130–250						
		perlitisches	–	100–200						
Temperguss	ferritisch	130	150–320							
	perlitisches	230	120–250							
N	Aluminium-Knetlegierungen	nicht aushärtbar	60			440–1500				400–1500
		aushärtbar, ausgehärtet	100			440–1500				400–1500
	Aluminium-Gusslegierungen	≤ 12 % Si, ausgehärtet	80			440–1500				400–1500
		≤ 12 % Si, aushärtbar, ausgehärtet	90			330–1200				300–1200
		≤ 12 % Si, nicht aushärtbar	130			220–1000				200–1000
	Kupfer und Kupferlegierungen (Bronze / Messing)	Automatenlegierung, Pb > 1%	–			220–600				200–600
		Messing, Rotguss	–			275–1000				250–1000
		Aluminiumbronze	90			165–400				150–400
		Kupfer und Elektrolytkupfer	100			330–800				300–800
	Nichtmetallische Werkstoffe	Duroplaste	100			90–1000				80–1000
Faserverstärkte Kunststoffe		–			85–500				75–500	
Hartgummi		–			90–300				80–300	
S	Warmfeste Legierungen	Fe-Basis, geglüht	200		20–60					
		Fe-Basis, ausgehärtet	280		20–60					
		Ni- oder Co-Basis, geglüht	250		20–60					
		Ni- oder Co-Basis 30–58 HRC, gegossen	–		20–30					
		Ni- oder Co-Basis 1500–2200 Nmm ² , ausgehärtet	–		20–30					
Titanlegierungen, Alpha+Beta-Legierungen	Rein-Titan	Rm 440		40–70						
	ausgehärtet	Rm 1050		20–40						
H	Gehärteter Stahl	gehärtet und angelassen	55 HRC							
		gehärtet und angelassen	60 HRC							
	Hartguss	gegossen	400							
Gehärtetes Gusseisen	gehärtet und angelassen	55 HRC								

Die Tabellenwerte sind Richtwerte. Es kann notwendig sein, die Werte den jeweiligen Bearbeitungsumständen anzupassen.



Duo-Mill -10 – Schnittdatenrichtwerte HFC-Fräsen mit SD..100415

2

ISO	Werkstoff		Brinell-Härte HB	Schnittgeschwindigkeit V _c [m/min]					
				AM5740	AP5325	AP5335	AP5340	AP5440	AP5830+
P	Unlegierter Stahl und Stahlguss	< 0,15 % C / vergütet	125		220–300	200–260	200–275	200–275	200–275
		0,15–0,45 % C / vergütet	150–250		220–300	200–260	200–275	200–275	200–275
		> 0,45 % C / vergütet	300		220–300	200–260	200–275	200–275	200–275
	Niedrig legierter Stahl und Stahlguss	geglüht	180		220–300	200–260	200–275	200–275	200–275
		vergütet	250–300		220–300	200–260	200–275	200–275	200–275
		vergütet	350		220–300	200–260	200–275	200–275	200–275
Hochlegierter Stahl, hochlegierter Werkzeugstahl und Stahlguss	geglüht	200		160–235	160–220	180–235	180–235	180–235	
	vergütet	350		160–235	160–220	180–235	180–235	180–235	
Nichtrostender Stahl	ferritisch, geglüht	200		160–235	160–220	180–220	180–220	180–220	
	Stahlguss	martensitisch, vergütet	325		160–235	160–220	180–220	180–220	
M	Nichtrostender Stahl	ferritisch, martensitisch geglüht	200	120–220					
		austenitisch, abgeschreckt	180	120–220					
		Duplex, abgeschreckt	230	120–220					
		martensitisch/austenitisch, abgeschreckt	330	120–220					
K	Grauguss	perlitisches/ferritisch	180	220–300					
		perlitisches/martensitisch	260	200–280					
	Gusseisen mit Kugelgraphit	ferritisch	160	200–250					
		perlitisches	–	180–235					
Temperguss	ferritisch	130	220–300						
	perlitisches	230	200–250						
N	Aluminium-Knetlegierungen	nicht aushärtbar	60						
		aushärtbar, ausgehärtet	100						
	Aluminium-Gusslegierungen	≤ 12 % Si, ausgehärtet	80						
		≤ 12 % Si, aushärtbar, ausgehärtet	90						
		≤ 12 % Si, nicht aushärtbar	130						
	Kupfer und Kupferlegierungen (Bronze / Messing)	Automatenlegierung, Pb > 1%	–						
		Messing, Rotguss	–						
Aluminiumbronze		90							
Kupfer und Elektrolytkupfer		100							
Nichtmetallische Werkstoffe	Duroplaste	100							
	Faserverstärkte Kunststoffe	–							
	Hartgummi	–							
S	Warmfeste Legierungen	Fe-Basis, geglüht	200	60–120					
		Fe-Basis, ausgehärtet	280	60–120					
		Ni- oder Co-Basis, geglüht	250	40–100					
		Ni- oder Co-Basis 30–58 HRC, gegossen	–	40–100					
		Ni- oder Co-Basis 1500–2200 Nmm ² , ausgehärtet	–	40–80					
Titanlegierungen, Alpha+Beta-Legierungen	Rein-Titan	Rm 440	40–80						
	ausgehärtet	Rm 1050	40–80						
H	Gehärteter Stahl	gehärtet und angelassen	55 HRC						
		gehärtet und angelassen	60 HRC						
	Hartguss	gegossen	400						
	Gehärtetes Gusseisen	gehärtet und angelassen	55 HRC						

Die Tabellenwerte sind Richtwerte. Es kann notwendig sein, die Werte den jeweiligen Bearbeitungsbedingungen anzupassen.

Duo-Mill -15 – Schnittdatenrichtwerte HFC-Fräsen mit SD..155020

ISO	Werkstoff		Brinell-Härte HB	Schnittgeschwindigkeit V _c [m/min]				
				AM5740	AP5325	AP5340	AP5440	AP5830+
P	Unlegierter Stahl und Stahlguss	< 0,15 % C / vergütet	125		220–300	200–275	200–275	200–275
		0,15–0,45 % C / vergütet	150–250		220–300	200–275	200–275	200–275
		> 0,45 % C / vergütet	300		220–300	200–275	200–275	200–275
	Niedrig legierter Stahl und Stahlguss	geglüht	180		220–300	200–275	200–275	200–275
		vergütet	250–300		220–300	200–275	200–275	200–275
		vergütet	350		220–300	200–275	200–275	200–275
	Hochlegierter Stahl, hochlegierter Werkzeugstahl und Stahlguss	geglüht	200		180–235	180–235	180–235	180–235
vergütet		350		180–235	180–235	180–235	180–235	
Nichtrostender Stahl	ferritisch, geglüht	200		180–235	180–235	180–220	180–220	
Stahlguss	martensitisch, vergütet	325		180–235	180–235	180–220	180–220	
M	Nichtrostender Stahl	ferritisch, martensitisch geglüht	200	120–220				
		austenitisch, abgeschreckt	180	120–220				
		Duplex, abgeschreckt	230	120–220				
		martensitisch/austenitisch, abgeschreckt	330	120–220				
K	Grauguss	perlitisch/ferritisch	180		220–300			
		perlitisch/martensitisch	260		200–280			
	Gusseisen mit Kugelgraphit	ferritisch	160		200–250			
		perlitisch	–		180–235			
Temperguss	ferritisch	130		220–280				
	perlitisch	230		200–250				
N	Aluminium-Knetlegierungen	nicht aushärtbar	60					
		aushärtbar, ausgehärtet	100					
	Aluminium-Gusslegierungen	≤ 12 % Si, ausgehärtet	80					
		≤ 12 % Si, aushärtbar, ausgehärtet	90					
		≤ 12 % Si, nicht aushärtbar	130					
	Kupfer und Kupferlegierungen (Bronze / Messing)	Automatenlegierung, Pb > 1%	–					
		Messing, Rotguss	–					
		Aluminiumbronze	90					
Kupfer und Elektrolytkupfer		100						
Nichtmetallische Werkstoffe	Duroplaste	100						
	Faserverstärkte Kunststoffe	–						
	Hartgummi	–						
S	Warmfeste Legierungen	Fe-Basis, geglüht	200	60–120				
		Fe-Basis, ausgehärtet	280	60–120				
		Ni- oder Co-Basis, geglüht	250	40–100				
		Ni- oder Co-Basis 30-58 HRC, gegossen	–	40–100				
		Ni- oder Co-Basis 1500-2200 Nmm ² , ausgehärtet	–	40–80				
	Titanlegierungen, Alpha+Beta-Legierungen	Rein-Titan	Rm 440	40–80				
	ausgehärtet	Rm 1050	40–80					
H	Gehärteter Stahl	gehärtet und angelassen	55 HRC					
		gehärtet und angelassen	60 HRC					
	Hartguss	gegossen	400					
Gehärtetes Gusseisen	gehärtet und angelassen	55 HRC						

Die Tabellenwerte sind Richtwerte. Es kann notwendig sein, die Werte den jeweiligen Bearbeitungsbedingungen anzupassen.



Duo-Mill -10 – Cutting data recommendation for Square shoulder with SD..100408...

2

ISO	Material	Brinell-Hardness HB	Cutting speed V _c [m/min]						
			AK5315	AM5740	AP5215	AP5330	AP5430	AP5830+	AN1015
P	Unalloyed steel and cast steel	< 0,15% C / hardened and tempered	125			100-220	100-220	100-220	
		0,15-0,45% C / hardened and tempered	150-250			100-220	100-220	100-220	
		> 0,45% C / hardened and tempered	300			100-220	100-220	100-220	
	Low alloyed steel and cast steel	annealed	180			80-220	80-220	80-220	
		hardened and tempered	250-300			80-220	80-220	80-220	
		hardened and tempered	350			80-220	80-220	80-220	
	High alloyed steel, high alloyed tool Steel and cast steel	annealed	200			80-180	80-180	80-180	
hardened and tempered		350			80-180	80-180	80-180		
Stainless steel Cast steel	ferritic, annealed	200			70-180	70-180	70-180		
	martensitic, hardened and tempered	325			70-180	70-180	70-180		
M	Stainless steel	ferritic, martensitic annealed	200	60-200					
		austenitic, chilled	180	60-200					
		Duplex, chilled	230	60-200					
		martensitic/austenitic, chilled	330	60-200					
K	Cast iron	pearlitic/ferritic	180	180-350					
		pearlitic/martensitic	260	140-280					
	Cast iron with nodular graphite	ferritisch	160	130-250					
		perlitisch	-	100-200					
Malleable cast iron	ferritic	130	150-320						
	pearlitic	230	120-250						
N	Aluminium alloys. long chipping	not heat treatable	60		440-1500			400-1500	
		heat treatable, heat treated	100		440-1500			400-1500	
	Casted aluminium alloys	≤ 12% Si, heat treated	80		440-1500			400-1500	
		≤ 12% Si, heat treatable, heat treated	90		330-1200			300-1200	
		≤ 12% Si, not heat treatable	130		220-1000			200-1000	
	Copper and copper alloys, (Brass / Bronze)	Lead alloys, Pb > 1%	-		220-600			200-600	
		Brass, Bronze	-		275-1000			250-1000	
		Aluminium bronze	90		165-400			150-400	
		Copper and elektrolyte copper	100		330-800			300-800	
Non ferrous materials	Duroplastic	100		90-1000			80-1000		
	Re-inforced plastics	-		85-500			75-500		
	Hard rubber	-		90-300			80-300		
S	High temperature resistant alloys	Fe-alloyed, annealed	200	20-60					
		Fe-alloyed, heat treated	280	20-60					
		Ni- or Co-alloyed, annealed	250	20-60					
		Ni- or Co-alloyed 30-58 HRC, casting	-	20-30					
		Ni- or Co-alloyed 1500-2200 Nmm ² , heat treated	-	20-30					
Titanium alloys	Pure titan	Rm 440	40-70						
Alpha- and Beta-alloys	heat treated	Rm 1050	20-40						
H	Hardened steel	hardened and tempered	55 HRC						
		hardened and tempered	60 HRC						
	Hard cast iron	casting	400						
Hardened cast iron	hardened and tempered	55 HRC							

The data given is only approximate values. It can be necessary to adjust this data to the individual machining operation.

Duo-Mill -15 – Cutting data recommendation for Square shoulder with SD..155012...

ISO	Material	Brinell-Hardness HB	Cutting speed V _c [m/min]						
			AK5315	AM5740	AP5215	AP5330	AP5430	AP5830+	AN1015
P	Unalloyed steel and cast steel	< 0,15% C / hardened and tempered	125			100–220	100–220	100–220	
		0,15–0,45% C / hardened and tempered	150–250			100–220	100–220	100–220	
		> 0,45% C / hardened and tempered	300			100–220	100–220	100–220	
	Low alloyed steel and cast steel	annealed	180			80–220	80–220	80–220	
		hardened and tempered	250–300			80–220	80–220	80–220	
		hardened and tempered	350			80–220	80–220	80–220	
	High alloyed steel, high alloyed tool Steel and cast steel	annealed	200			80–220	80–220	80–220	
hardened and tempered		350			80–220	80–220	80–220		
Stainless steel Cast steel	ferritic, annealed	200			70–180	70–180	70–180		
	martensitic, hardened and tempered	325			70–180	70–180	70–180		
M	Stainless steel	ferritic, martensitic annealed	200	60–200					
		austenitic, chilled	180	60–200					
		Duplex, chilled	230	60–200					
		martensitic/austenitic, chilled	330	60–200					
K	Cast iron	pearlitic/ferritic	180	180–350					
		pearlitic/martensitic	260	140–280					
	Cast iron with nodular graphite	ferritisch	160	130–250					
		perlitisch	–	100–200					
Malleable cast iron	ferritic	130	150–320						
	pearlitic	230	120–250						
N	Aluminium alloys. long chipping	not heat treatable	60		440–1500			400–1500	
		heat treatable, heat treated	100		440–1500			400–1500	
	Casted aluminium alloys	≤ 12% Si, heat treated	80		440–1500			400–1500	
		≤ 12% Si, heat treatable, heat treated	90		330–1200			300–1200	
		≤ 12% Si, not heat treatable	130		220–1000			200–1000	
	Copper and copper alloys, (Brass / Bronze)	Lead alloys, Pb > 1%	–		220–600			200–600	
		Brass, Bronze	–		275–1000			250–1000	
		Aluminium bronze	90		165–400			150–400	
		Copper and elektrolyte copper	100		330–800			300–800	
	Non ferrous materials	Duroplastic	100		90–1000			80–1000	
Re-inforced plastics		–		85–500			75–500		
Hard rubber		–		90–300			80–300		
S	High temperature resistant alloys	Fe-alloyed, annealed	200	20–60					
		Fe-alloyed, heat treated	280	20–60					
		Ni- or Co-alloyed, annealed	250	20–60					
		Ni- or Co-alloyed 30-58 HRC, casting	–	20–30					
		Ni- or Co-alloyed 1500-2200 Nmm ² , heat treated	–	20–30					
Titanium alloys	Pure titan	Rm 440	40–70						
Alpha- and Beta-alloys	heat treated	Rm 1050	20–40						
H	Hardened steel	hardened and tempered	55 HRC						
		hardened and tempered	60 HRC						
	Hard cast iron	casting	400						
Hardened cast iron	hardened and tempered	55 HRC							

The data given is only approximate values. It can be necessary to adjust this data to the individual machining operation.

Duo-Mill -10 – Cutting data recommendation for HFC-milling with SD..100415

ISO	Material	Brinell-Hardness HB	Cutting speed V _c [m/min]					
			AM5740	AP5325	AP5335	AP5340	AP5440	AP5830+
P	Unalloyed steel and cast steel	< 0,15% C / hardened and tempered	125	220–300	200–260	200–275	200–275	200–275
		0,15–0,45% C / hardened and tempered	150–250	220–300	200–260	200–275	200–275	200–275
		> 0,45% C / hardened and tempered	300	220–300	200–260	200–275	200–275	200–275
	Low alloyed steel and cast steel	annealed	180	220–300	200–260	200–275	200–275	200–275
		hardened and tempered	250–300	220–300	200–260	200–275	200–275	200–275
		hardened and tempered	350	220–300	200–260	200–275	200–275	200–275
	High alloyed steel, high alloyed tool Steel and cast steel	annealed	200	160–235	160–220	180–235	180–235	180–235
hardened and tempered		350	160–235	160–220	180–235	180–235	180–235	
Stainless steel Cast steel	ferritic, annealed	200	160–235	160–220	180–220	180–220	180–220	
	martensitic, hardened and tempered	325	160–235	160–220	180–220	180–220	180–220	
M	Stainless steel	ferritic, martensitic annealed	200	120–220				
		austenitic, chilled	180	120–220				
		Duplex, chilled	230	120–220				
		martensitic/austenitic, chilled	330	120–220				
K	Cast iron	pearlitic/ferritic	180	220–300				
		pearlitic/martensitic	260	200–280				
	Cast iron with nodular graphite	ferritisch	160	200–250				
		perlitisch	–	180–235				
Malleable cast iron	ferritic	130	220–300					
	pearlitic	230	200–250					
N	Aluminium alloys. long chipping	not heat treatable	60					
		heat treatable, heat treated	100					
	Casted aluminium alloys	≤ 12% Si, heat treated	80					
		≤ 12% Si, heat treatable, heat treated	90					
		≤ 12% Si, not heat treatable	130					
	Copper and copper alloys, (Brass / Bronze)	Lead alloys, Pb > 1%	–					
		Brass, Bronze	–					
Aluminium bronze		90						
Copper and elektrolyte copper		100						
Non ferrous materials	Duroplastic	100						
	Re-inforced plastics	–						
	Hard rubber	–						
S	High temperature resistant alloys	Fe-alloyed, annealed	200	60–120				
		Fe-alloyed, heat treated	280	60–120				
		Ni- or Co-alloyed, annealed	250	40–100				
		Ni- or Co-alloyed 30-58 HRC, casting	–	40–100				
		Ni- or Co-alloyed 1500-2200 Nmm ² , heat treated	–	40–80				
Titanium alloys	Pure titan	Rm 440	40–80					
Alpha- and Beta-alloys	heat treated	Rm 1050	40–80					
H	Hardened steel	hardened and tempered	55 HRC					
		hardened and tempered	60 HRC					
	Hard cast iron	casting	400					
Hardened cast iron	hardened and tempered	55 HRC						

The data given is only approximate values. It can be necessary to adjust this data to the individual machining operation.

Duo-Mill -15 – Cutting data recommendation for HFC-milling with SD..155020

ISO	Material	Brinell-Hardness HB	Cutting speed V _c [m/min]				
			AM5740	AP5325	AP5340	AP5440	AP5830+
P	Unalloyed steel and cast steel	< 0,15% C / hardened and tempered	125	220–300	200–275	200–275	200–275
		0,15–0,45% C / hardened and tempered	150–250	220–300	200–275	200–275	200–275
		> 0,45% C / hardened and tempered	300	220–300	200–275	200–275	200–275
	Low alloyed steel and cast steel	annealed	180	220–300	200–275	200–275	200–275
		hardened and tempered	250–300	220–300	200–275	200–275	200–275
		hardened and tempered	350	220–300	200–275	200–275	200–275
	High alloyed steel, high alloyed tool Steel and cast steel	annealed	200	180–235	180–235	180–235	180–235
hardened and tempered		350	180–235	180–235	180–235	180–235	
Stainless steel Cast steel	ferritic, annealed	200	180–235	180–235	180–220	180–220	
	martensitic, hardened and tempered	325	180–235	180–235	180–220	180–220	
M	Stainless steel	ferritic, martensitic annealed	200	120–220			
		austenitic, chilled	180	120–220			
		Duplex, chilled	230	120–220			
		martensitic/austenitic, chilled	330	120–220			
K	Cast iron	pearlitic/ferritic	180	220–300			
		pearlitic/martensitic	260	200–280			
	Cast iron with nodular graphite	ferritisch	160	200–250			
		perlitisch	–	180–235			
Malleable cast iron	ferritic	130	220–280				
	pearlitic	230	200–250				
N	Aluminium alloys. long chipping	not heat treatable	60				
		heat treatable, heat treated	100				
	Casted aluminium alloys	≤ 12% Si, heat treated	80				
		≤ 12% Si, heat treatable, heat treated	90				
		≤ 12% Si, not heat treatable	130				
	Copper and copper alloys, (Brass / Bronze)	Lead alloys, Pb > 1%	–				
		Brass, Bronze	–				
		Aluminium bronze	90				
		Copper and elektrolyte copper	100				
	Non ferrous materials	Duroplastic	100				
Re-inforced plastics		–					
Hard rubber		–					
S	High temperature resistant alloys	Fe-alloyed, annealed	200	60–120			
		Fe-alloyed, heat treated	280	60–120			
		Ni- or Co-alloyed, annealed	250	40–100			
		Ni- or Co-alloyed 30-58 HRC, casting	–	40–100			
		Ni- or Co-alloyed 1500-2200 Nmm ² , heat treated	–	40–80			
	Titanium alloys	Pure titan	Rm 440	40–80			
Alpha- and Beta-alloys	heat treated	Rm 1050	40–80				
H	Hardened steel	hardened and tempered	55 HRC				
		hardened and tempered	60 HRC				
	Hard cast iron	casting	400				
Hardened cast iron	hardened and tempered	55 HRC					

The data given is only approximate values. It can be necessary to adjust this data to the individual machining operation.



Duo-Mill -10 – Spallamento retto con inserto SD..100408...

2

ISO	Materiale	Durezza Brinell HB	Velocità di taglio V _c [m/min]							
			AK5315	AM5740	AP5215	AP5330	AP5430	AP5830+	ANI015	
P	Acciai non legati	< 0,15 % C / bonificato	125				100-220	100-220	100-220	
		0,15-0,45 % C / bonificato	150-250				100-220	100-220	100-220	
		> 0,45 % C / bonificato	300				100-220	100-220	100-220	
	Acciai debolmente legati e Ghise acciaiose	ricotto	180				80-220	80-220	80-220	
		bonificato	250-300				80-220	80-220	80-220	
		bonificato	350				80-220	80-220	80-220	
	Acciai fortemente legati	ricotto	200				80-180	80-180	80-180	
Acciai da costruzione e Ghise acciaiose	bonificato	350				80-180	80-180	80-180		
Acciai inossidabili Ghisa acciaiosa	ferritico, ricotto	200				70-180	70-180	70-180		
	martensitico, bonificato	325				70-180	70-180	70-180		
M	Acciai inossidabili	ferritico, martensitico ricotto	200		60-200					
		austenitico, temprato	180		60-200					
		Duplex, temprato	230		60-200					
		martensitico/austenitico, temprato	330		60-200					
K	Ghisa grigia	perlitica/ferritico	180	180-350						
		perlitica/martensitico	260	140-280						
	Ghisa sferoidale	ferritico	160	130-250						
		perlitica	-	100-200						
Ghisa temprata	ferritico	130	150-320							
	perlitica	230	120-250							
N	Leghe di Alluminio stampato	non invecchiato	60			440-1500				400-1500
		temporabile, invecchiato	100			440-1500				400-1500
	Leghe di Alluminio da fusione	≤ 12 % Si, invecchiato	80			440-1500				400-1500
		≤ 12 % Si, temporabile, invecchiato	90			330-1200				300-1200
		≤ 12 % Si, non invecchiato	130			220-1000				200-1000
	Rame e Leghe di Rame (Bronzo / Ottone)	Automatici, Pb > 1 %	-			220-600				200-600
		Ottone, Bronzo	-			275-1000				250-1000
		Bronzoalluminio	90			165-400				150-400
Rame e Rame Elettrolitico		100			330-800				300-800	
Materiali non metallici	Duroplastiche	100			90-1000				80-1000	
	Plastiche rinforzate	-			85-500				75-500	
	Gomme dure	-			90-300				80-300	
S	Leghe resistenti al calore	Base-Fe, ricotto	200			20-60				
		Base-Fe, invecchiato	280			20-60				
		Base Ni o Co, ricotto	250			20-60				
		Base Ni o Co 30-58 HRC, da fusione	-			20-30				
		Base Ni o Co 1500-2200 Nmm ² , invecchiato	-			20-30				
Leghe di Titanio,	Titanio puro	Rm 440			40-70					
Leghe Alpha+Beta	invecchiato	Rm 1050			20-40					
H	Acciaio Temprato	temprato e rinvenuto	55 HRC							
		temprato e rinvenuto	60 HRC							
	Getti Temprati	da fusione	400							
Ghisa Temprata	temprato e rinvenuto	55 HRC								

Dati indicativi. Può essere necessario adattarli alle singole applicazioni.

Duo-Mill -15 – Spallamento retto con inserto SD..155012...

ISO	Materiale	Durezza Brinell HB	Velocità di taglio V _c [m/min]							
			AK5315	AM5740	AP5215	AP5330	AP5430	AP5830+	AN1015	
P	Acciai non legati	< 0,15 % C / bonificato	125				100-220	100-220	100-220	
		0,15-0,45 % C / bonificato	150-250				100-220	100-220	100-220	
		> 0,45 % C / bonificato	300				100-220	100-220	100-220	
	Acciai debolmente legati e Ghise acciaiose	ricotto	180				80-220	80-220	80-220	
		bonificato	250-300				80-220	80-220	80-220	
		bonificato	350				80-220	80-220	80-220	
	Acciai fortemente legati	ricotto	200				80-220	80-220	80-220	
Acciai da costruzione e Ghise acciaiose	bonificato	350				80-220	80-220	80-220		
Acciai inossidabili Ghisa acciaiosa	ferritico, ricotto	200				70-180	70-180	70-180		
	martensitico, bonificato	325				70-180	70-180	70-180		
M	Acciai inossidabili	ferritico, martensitico ricotto	200	60-200						
		austenitico, temprato	180	60-200						
		Duplex, temprato	230	60-200						
		martensitico/austenitico, temprato	330	60-200						
K	Ghisa grigia	perlitica/ferritico	180	180-350						
		perlitica/martensitico	260	140-280						
	Ghisa sferoidale	ferritico	160	130-250						
		perlitica	-	100-200						
Ghisa temprata	ferritico	130	150-320							
	perlitica	230	120-250							
N	Leghe di Alluminio stampato	non invecchiato	60				440-1500			400-1500
		temporabile, invecchiato	100				440-1500			400-1500
	Leghe di Alluminio da fusione	≤ 12 % Si, invecchiato	80				440-1500			400-1500
		≤ 12 % Si, temporabile, invecchiato	90				330-1200			300-1200
		≤ 12 % Si, non invecchiato	130				220-1000			200-1000
	Rame e Leghe di Rame (Bronzo / Ottone)	Automatici, Pb > 1 %	-				220-600			200-600
		Ottone, Bronzo	-				275-1000			250-1000
		Bronzoalluminio	90				165-400			150-400
Rame e Rame Elettrolitico		100				330-800			300-800	
Materiali non metallici	Duroplastiche	100				90-1000			80-1000	
	Plastiche rinforzate	-				85-500			75-500	
	Gomme dure	-				90-300			80-300	
S	Leghe resistenti al calore	Base-Fe, ricotto	200	20-60						
		Base-Fe, invecchiato	280	20-60						
		Base Ni o Co, ricotto	250	20-60						
		Base Ni o Co 30-58 HRC, da fusione	-	20-30						
		Base Ni o Co 1500-2200 Nmm ² , invecchiato	-	20-30						
Leghe di Titanio,	Titanio puro	Rm 440	40-70							
Leghe Alpha+Beta	invecchiato	Rm 1050	20-40							
H	Acciaio Temprato	temprato e rinvenuto	55 HRC							
		temprato e rinvenuto	60 HRC							
	Getti Temprati	da fusione	400							
	Ghisa Temprata	temprato e rinvenuto	55 HRC							

Dati indicativi. Può essere necessario adattarli alle singole applicazioni.



Duo-Mill -10 – HFC-Fresatura ad alto avanzamento con inserto SD..100415

ISO	Materiale	Durezza Brinell HB	Velocità di taglio V _c [m/min]					
			AM5740	AP5325	AP5335	AP5340	AP5440	AP5830+
P	Acciai non legati	< 0,15 % C / bonificato	125	220-300	200-260	200-275	200-275	200-275
		0,15-0,45 % C / bonificato	150-250	220-300	200-260	200-275	200-275	200-275
		> 0,45 % C / bonificato	300	220-300	200-260	200-275	200-275	200-275
	Acciai debolmente legati e Ghise acciaiose	ricotto	180	220-300	200-260	200-275	200-275	200-275
		bonificato	250-300	220-300	200-260	200-275	200-275	200-275
		bonificato	350	220-300	200-260	200-275	200-275	200-275
	Acciai fortemente legati	ricotto	200	160-235	160-220	180-235	180-235	180-235
Acciai da costruzione e Ghise acciaiose	bonificato	350	160-235	160-220	180-235	180-235	180-235	
Acciai inossidabili	ferritico, ricotto	200	160-235	160-220	180-220	180-220	180-220	
Ghisa acciaiosa	martensitico, bonificato	325	160-235	160-220	180-220	180-220	180-220	
M	Acciai inossidabili	ferritico, martensitico ricotto	200	120-220				
		austenitico, temprato	180	120-220				
		Duplex, temprato	230	120-220				
		martensitico/austenitico, temprato	330	120-220				
K	Ghisa grigia	perlitica/ferritico	180	220-300				
		perlitica/martensitico	260	200-280				
	Ghisa sferoidale	ferritico	160	200-250				
		perlitica	-	180-235				
Ghisa temprata	ferritico	130	220-300					
	perlitica	230	200-250					
N	Leghe di Alluminio stampato	non invecchiato	60					
		temporabile, invecchiato	100					
	Leghe di Alluminio da fusione	≤ 12 % Si, invecchiato	80					
		≤ 12 % Si, temporabile, invecchiato	90					
		≤ 12 % Si, non invecchiato	130					
	Rame e Leghe di Rame (Bronzo / Ottone)	Automatici, Pb > 1 %	-					
		Ottone, Bronzo	-					
Bronzoalluminio		90						
Rame e Rame Elettrolitico		100						
Materiali non metallici	Duroplastiche	100						
	Plastiche rinforzate	-						
	Gomme dure	-						
S	Leghe resistenti al calore	Base-Fe, ricotto	200	60-120				
		Base-Fe, invecchiato	280	60-120				
		Base Ni o Co, ricotto	250	40-100				
		Base Ni o Co 30-58 HRC, da fusione	-	40-100				
		Base Ni o Co 1500-2200 Nmm ² , invecchiato	-	40-80				
Leghe di Titanio,	Titanio puro	Rm 440	40-80					
Leghe Alpha+Beta	invecchiato	Rm 1050	40-80					
H	Acciaio Temprato	temprato e rinvenuto	55 HRC					
		temprato e rinvenuto	60 HRC					
	Getti Temprati	da fusione	400					
Ghisa Temprata	temprato e rinvenuto	55 HRC						

Dati indicativi. Può essere necessario adattarli alle singole applicazioni.

Duo-Mill -15 – HFC-Fresatura ad alto avanzamento con inserto SD..155020

ISO	Materiale	Durezza Brinell HB	Velocità di taglio V _c [m/min]				
			AM5740	AP5325	AP5340	AP5440	AP5830+
P	Acciai non legati	< 0,15 % C / bonificato	125	220-300	200-275	200-275	200-275
		0,15-0,45 % C / bonificato	150-250	220-300	200-275	200-275	200-275
		> 0,45 % C / bonificato	300	220-300	200-275	200-275	200-275
	Acciai debolmente legati e Ghise acciaiose	ricotto	180	220-300	200-275	200-275	200-275
		bonificato	250-300	220-300	200-275	200-275	200-275
		bonificato	350	220-300	200-275	200-275	200-275
	Acciai fortemente legati	ricotto	200	180-235	180-235	180-235	180-235
Acciai da costruzione e Ghise acciaiose	bonificato	350	180-235	180-235	180-235	180-235	
Acciai inossidabili Ghisa acciaiosa	ferritico, ricotto	200	180-235	180-235	180-220	180-220	
	martensitico, bonificato	325	180-235	180-235	180-220	180-220	
M	Acciai inossidabili	ferritico, martensitico ricotto	200	120-220			
		austenitico, temprato	180	120-220			
		Duplex, temprato	230	120-220			
		martensitico/austenitico, temprato	330	120-220			
K	Ghisa grigia	perlitica/ferritico	180	220-300			
		perlitica/martensitico	260	200-280			
	Ghisa sferoidale	ferritico	160	200-250			
		perlitica	-	180-235			
Ghisa temprata	ferritico	130	220-280				
	perlitica	230	200-250				
N	Leghe di Alluminio stampato	non invecchiato	60				
		temporabile, invecchiato	100				
	Leghe di Alluminio da fusione	≤ 12 % Si, invecchiato	80				
		≤ 12 % Si, temporabile, invecchiato	90				
		≤ 12 % Si, non invecchiato	130				
	Rame e Leghe di Rame (Bronzo / Ottone)	Automatici, Pb > 1 %	-				
		Ottone, Bronzo	-				
		Bronzoalluminio	90				
Materiali non metallici	Rame e Rame Elettrolitico	100					
	Duroplastiche	100					
	Plastiche rinforzate	-					
	Gomme dure	-					
S	Leghe resistenti al calore	Base-Fe, ricotto	200	60-120			
		Base-Fe, invecchiato	280	60-120			
		Base Ni o Co, ricotto	250	40-100			
		Base Ni o Co 30-58 HRC, da fusione	-	40-100			
		Base Ni o Co 1500-2200 Nmm ² , invecchiato	-	40-80			
Leghe di Titanio,	Titanio puro	Rm 440	40-80				
Leghe Alpha+Beta	invecchiato	Rm 1050	40-80				
H	Acciaio Temprato	temprato e rinvenuto	55 HRC				
		temprato e rinvenuto	60 HRC				
	Getti Temprati	da fusione	400				
Ghisa Temprata	temprato e rinvenuto	55 HRC					

Dati indicativi. Può essere necessario adattarli alle singole applicazioni.



Wendeschnidplatte Duo-Mill -10 – Schnittdatenrichtwerte

Indexable insert Duo-Mill -10 – Cutting data recommendation

Inserto Duo-Mill -10 – Parametri di taglio consigliati

ISO	Eckfräsen/Square shoulder/Fresatura a Spallamento Retto Werkstoff/Material/Materiale	Mittlere Bearbeitung Medium machining Media asportazione			Schrupp-Bearbeitung Rough machining Sgrossatura		
		v_c [m/min]	f_z [mm]	a_p [mm]	v_c [m/min]	f_z [mm]	a_p [mm]
		P	Stahl/Steel/Acciaio	120–220	0,1–0,20	< 3	60–180
M	Rostfreier Stahl/Stainless steel/Acciaio inossidabile	90–200	0,1–0,35	< 3	60–120	0,1–0,25	< 5
K	Guss/Cast iron/Ghisa	170–350	0,1–0,20	< 3	120–200	0,1–0,25	< 5
N	NE-Metalle/Non ferrous materials/Materiali non ferrosi	400–1500	0,1–0,30	< 3	400–1000	0,1–0,20	< 8
S	Hochwarmfest/High temperature resistant alloys/Leghe resistenti al calore	40–120	0,1–0,20	< 3	30–90	0,1–0,20	< 5

ISO	HFC-Fräsen/HFC-milling/HFC-Fresatura ad alto avanzamento Werkstoff/Material/Materiale	v_c [m/min]	f_z [mm]	a_p [mm]
		P	Stahl/Steel/Acciaio	180–300
M	Rostfreier Stahl/Stainless steel/Acciaio inossidabile	120–220	0,2–1,5	0,25–1,5
K	Guss/Stainless steel/Ghisa	200–300	0,3–2,5	0,25–1,5
S	Hochwarmfest/High temperature resistant alloys/Leghe resistenti al calore	40–120	0,2–1,0	0,25–1,2

Wendeschnidplatte Duo-Mill -15 – Schnittdatenrichtwerte

Indexable insert Duo-Mill -15 – Cutting data recommendation

Inserto Duo-Mill -15 – Parametri di taglio consigliati

ISO	Eckfräsen/Square shoulder/Fresatura a Spallamento Retto Werkstoff/Material/Materiale	Mittlere Bearbeitung Medium machining Media asportazione			Schrupp-Bearbeitung Rough machining Sgrossatura		
		v_c [m/min]	f_z [mm]	a_p [mm]	v_c [m/min]	f_z [mm]	a_p [mm]
		P	Stahl/Steel/Acciaio	120–220	0,1–0,35	< 5	60–180
M	Rostfreier Stahl/Stainless steel/Acciaio inossidabile	90–200	0,1–0,35	< 5	60–120	0,1–0,25	< 10
K	Guss/Cast iron/Ghisa	170–350	0,1–0,20	< 5	120–200	0,1–0,25	< 10
N	NE-Metalle/Non ferrous materials/Materiali non ferrosi	400–1500	0,1–0,30	< 5	400–1000	0,1–0,20	< 12
S	Hochwarmfest/High temperature resistant alloys/Leghe resistenti al calore	40–120	0,1–0,20	< 5	30–90	0,1–0,20	< 10

ISO	HFC-Fräsen/HFC-milling/HFC-Fresatura ad alto avanzamento Werkstoff/Material/Materiale	v_c [m/min]	f_z [mm]	a_p [mm]
		P	Stahl/Steel/Acciaio	180–300
M	Rostfreier Stahl/Stainless steel/Acciaio inossidabile	120–220	0,5–2,0	0,5–2,5
K	Guss/Stainless steel/Ghisa	130–300	0,5–2,5	0,5–2,5
S	Hochwarmfest/High temperature resistant alloys/Leghe resistenti al calore	40–120	0,5–1,5	0,5–2,0

Die Tabellenwerte sind Richtwerte. Es kann notwendig sein, die Werte den jeweiligen Bearbeitungsumständen anzupassen.

The data given is only approximate values. It can be necessary to adjust this data to the individual machining operation.

Dati indicativi. Può essere necessario adattarli alle singole applicazioni.

ISO-Application area
ISO-Campi di applicazione

ISO	Hartmetall beschichtet Carbide coated Metallo duro rivestito	Hartmetall unbeschichtet Carbide uncoated Metallo duro non rivestito	Schneidstoff Cutting material Materiale da taglio	Anwendung Application Parametri
P Stahl, Stahlguss, langspanender Tempguss <i>Steel, cast steel, long chipping malleable iron</i> Acciaio, acciaio colato, ghisa temprata a truciolo lungo	10		Zähigkeit Toughness Tenacità Verschleißbeständigkeit Resistenza all'usura	Vorschub Feed rate Avanzamento Schnittgeschwindigkeit Cutting speed Velocità di taglio
	20	AP5325		
	30	AP5330		
	30	AP5430		
	40	AP5340		
40	AP5440			
40	AP5335			
40	AP5830+			
M Rostfreier Stahl, Stahlguss, Manganstahl, Automatenstahl <i>Stainless steel, cast steel, manganese steel, free cutting steel</i> Acciaio inossidabile, acciaio colato, acciaio al manganese, ghisa legata, ghisa temprata, acciaio automatico, leghe refrattarie	10		Zähigkeit Toughness Tenacità Verschleißbeständigkeit Resistenza all'usura	Vorschub Feed rate Avanzamento Schnittgeschwindigkeit Cutting speed Velocità di taglio
	20			
	30			
	40	AM5740		
K Grauguss, Kokillenhartguss, kurzspanender Tempguss <i>Grey cast iron, chilled hard cast iron, short chipping malleable iron</i> Ghisa grigia, ghisa fusa in conchiglia, ghisa temprata a truciolo corto, acciaio temprato, metalli non ferrosi, plastica, legno	10		Zähigkeit Toughness Tenacità Verschleißbeständigkeit Resistenza all'usura	Vorschub Feed rate Avanzamento Schnittgeschwindigkeit Cutting speed Velocità di taglio
	20	AP5325		
	30	AM5315		
	40			
N Aluminium und Al-Legierungen, nichtmetallische Werkstoffe <i>Aluminium and Al-alloys, non ferrous materials</i> Alluminio e leghe di alluminio, materiali non metallici	10	AP5215	Zähigkeit Toughness Tenacità Verschleißbeständigkeit Resistenza all'usura	Vorschub Feed rate Avanzamento Schnittgeschwindigkeit Cutting speed Velocità di taglio
	20			
	30	AM1015		
	40			
S Warmfeste Legierungen, Titanlegierungen <i>High temperature resistant alloys, Titanium alloys</i> Leghe refrattarie, leghe di titanio	10		Zähigkeit Toughness Tenacità Verschleißbeständigkeit Resistenza all'usura	Vorschub Feed rate Avanzamento Schnittgeschwindigkeit Cutting speed Velocità di taglio
	20			
	30	AM5740		
	40			
H Gehärteter Stahl, Hartguss <i>Hardened Steel, hard cast iron</i> Acciaio temprato, ghisa temprata	10		Zähigkeit Toughness Tenacità Verschleißbeständigkeit Resistenza all'usura	Vorschub Feed rate Avanzamento Schnittgeschwindigkeit Cutting speed Velocità di taglio
	20			
	30			
	40			

2

Hauptanwendungsbereich / Main application area / Applicazione principale



Nebenanwendungsbereich / Secondary application area / Applicazione secondaria



Einsatzdaten WSP-10 Eckfräser

Cutting data indexable inserts SD...10... Square shoulder

Parametri di taglio suggeriti con inserti SD...10... Fresatura a Spallamento Retto

Zirkulares Eintauchen / Helical interpolation / Fresatura circolare

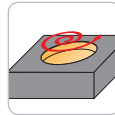
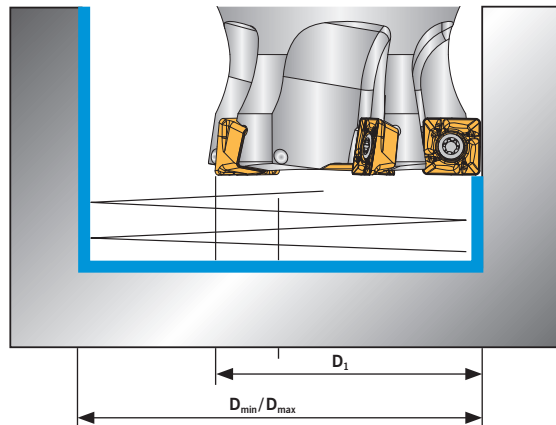

D ₁	D _{min}	D _{max}
25	35	48
32	49	62
40	65	78
50	85	98
63	111	124
80	145	158
100	185	198
125	235	248
160	305	318

D_{min} = kleinster Bohrungsdurchmesser
 minimum bore diameter
 diametro minimo di foro

D_{max} = größter Bohrungsdurchmesser für ebene Bodenflächen
 maximum bore diameter for flat area
 diametro massimo foro per parte piana

Axiales Eintauchen / Plunge milling / Fresatura assiale

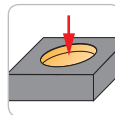
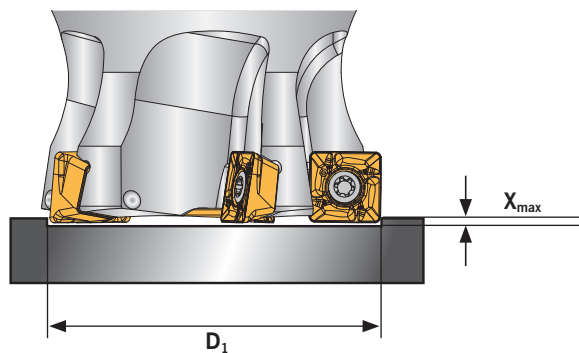

D ₁	X _{max}
D25–D160	1,8 mm

Schräges Eintauchen / Ramping / Fresatura in rampa

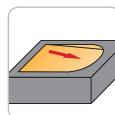
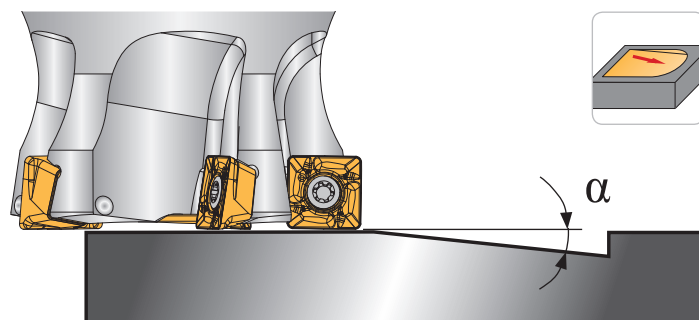

D ₁	α	Mindest-Verfahrweg Minimum travel Corsa minima
25	10,2	10
32	6,0	17
40	4,0	25
50	2,9	35
63	2,1	48
80	1,6	65
100	1,2	85
125	0,9	110
160	0,7	145

Einsatzdaten WSP-15 Eckfräser

Cutting data indexable inserts SD...15... Square shoulder

Parametri di taglio suggeriti con inserti SD...15... Fresatura a Spallamento Retto

Zirkulares Eintauchen / Helical interpolation / Fresatura circolare

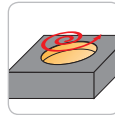
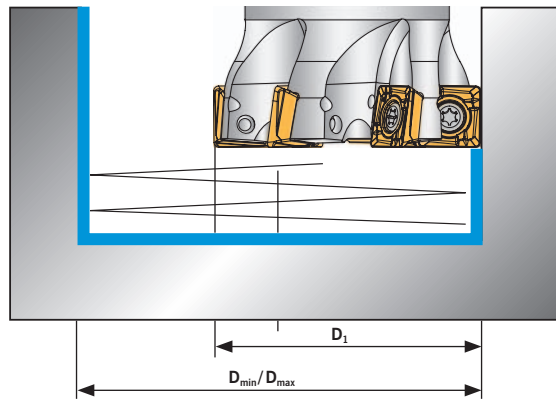

D ₁	D _{min}	D _{max}
50	77,5	98
63	103,5	124
80	137	158
100	177,5	198
125	227	248
160	297	318

D_{min} = kleinster Bohrungsdurchmesser
 minimum bore diameter
 diametro minimo di foro

D_{max} = größter Bohrungsdurchmesser für ebene Bodenflächen
 maximum bore diameter for flat area
 diametro massimo foro per parte piana



Axiales Eintauchen / Plunge milling / Fresatura assiale

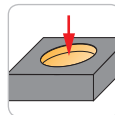
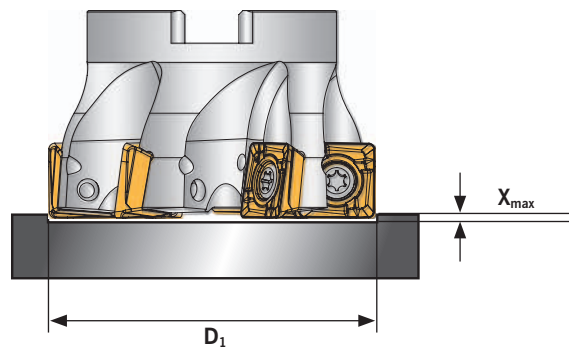

D ₁	X _{max}
D50–D160	2,0 mm

Schräges Eintauchen / Ramping / Fresatura in rampa

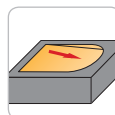
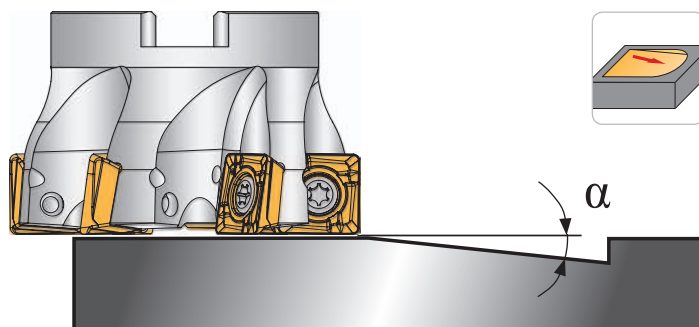

D ₁	α	Mindest-Verfahrweg Minimum travel Corsa minima
50	4,2	27
63	2,8	40
80	2,0	58
100	1,5	78
125	1,1	103
160	0,8	138

Einsatzdaten WSP-10 HFC-Fräser

Cutting data indexable inserts SD...10... HFC-milling
 Parametri di taglio suggeriti con inserti SD...10... HFC-Fresatura

Zirkulares Eintauchen / Helical interpolation / Fresatura circolare

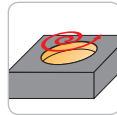
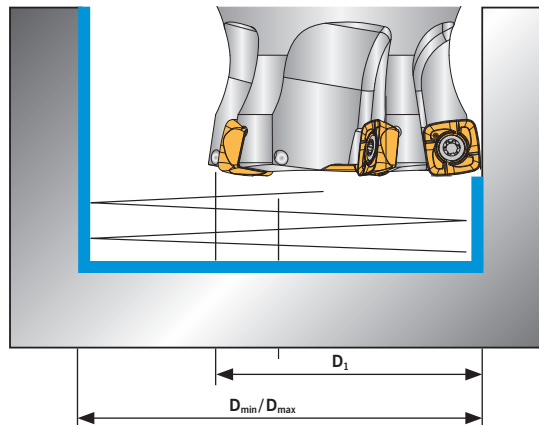

D ₁	D _{min}	D _{max}
25	39	48
32	53	62
40	69	78
50	89	98
63	115	124
80	149	158
100	189	198
125	239	248
160	309	318

D_{min} = **kleinster Bohrungsdurchmesser**
 minimum bore diameter
 diametro minimo di foro

D_{max} = **größter Bohrungsdurchmesser für ebene Bodenflächen**
 maximum bore diameter for flat area
 diametro massimo foro per parte piana

Axiales Eintauchen / Plunge milling / Fresatura assiale

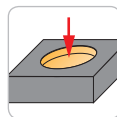
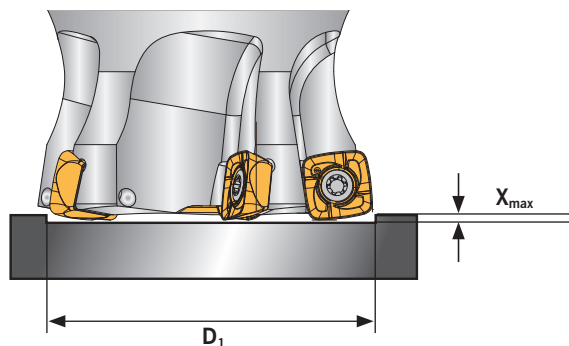

D ₁	X _{max}
D25–D160	1,2 mm

Schräges Eintauchen / Ramping / Fresatura in rampa

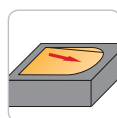
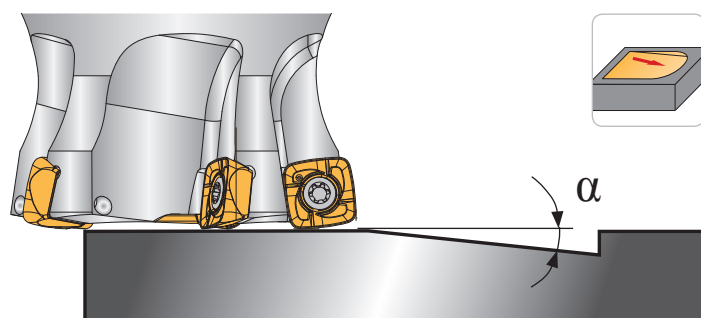

D ₁	α	Mindest-Verfahrweg Minimum travel Corsa minima
25	4,9	14
32	3,2	21
40	2,3	29
50	1,8	39
63	1,3	52
80	1,0	69
100	0,75	89
125	0,6	114
160	0,4	149

Einsatzdaten WSP-15 HFC-Fräser

Cutting data indexable inserts SD...15... HFC-milling
 Parametri di taglio suggeriti con inserti SD...15... HFC-Fresatura

Zirkulares Eintauchen / Helical interpolation / Fresatura circolare

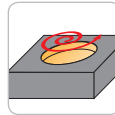
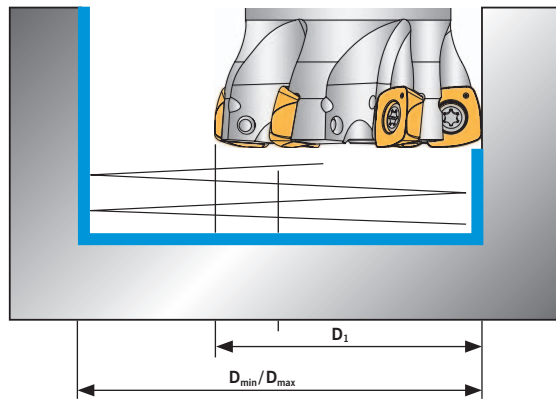

D ₁	D _{min}	D _{max}
50	82	98
63	108	124
80	142	158
100	182	198
125	232	248
160	302	318

D_{min} = kleinster Bohrungsdurchmesser
 minimum bore diameter
 diametro minimo di foro

D_{max} = größter Bohrungsdurchmesser für ebene Bodenflächen
 maximum bore diameter for flat area
 diametro massimo foro per parte piana

2

Axiales Eintauchen / Plunge milling / Fresatura assiale

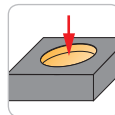
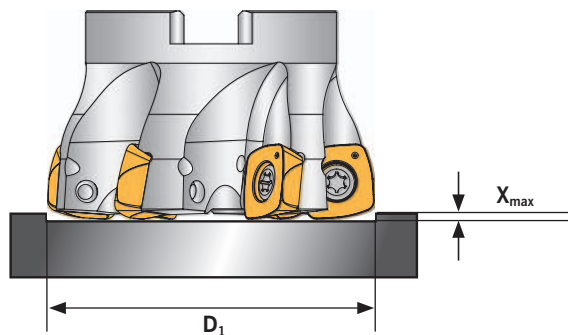

D ₁	X _{max}
D50–D160	1,8 mm

Schräges Eintauchen / Ramping / Fresatura in rampa

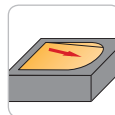
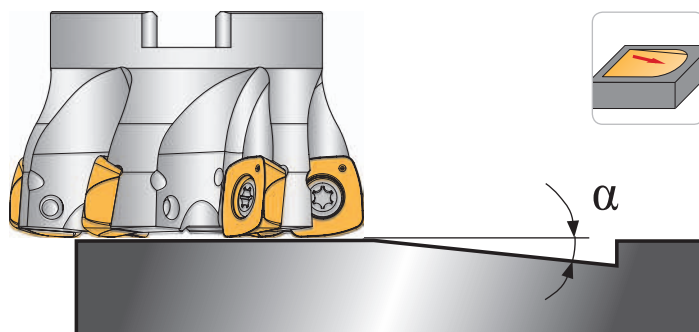

D ₁	α	Mindest-Verfahrweg Minimum travel Corsa minima
50	3,2	32
63	2,3	45
80	1,66	62
100	1,25	82
125	0,96	107
160	0,72	142

Planfräsen extrem!*Extreme milling!*

Fresatura con parametri estremi!

Speziell entwickelte Hartmetallsorten und die optimal abgestimmte Spanleitstufe ermöglichen diese enorme Leistungsfähigkeit. Optimierte Beschichtungen garantieren maximales Zeitspanvolumen.

To achieve performance like this we apply especially developed carbide grades and optimized chip breaker geometries. Latest coating technology guarantees maximum tool performance.

Per ottenere tali risultati sono stati sviluppati gradi speciali e geometrie di rompitruciolo ottimizzate a queste applicazioni. La più recente tecnologia di rivestimento garantisce inoltre il massimo delle prestazioni e durate.

Duo-Mill -10 Vorschübe bis zu 2 mm pro Zahn

Feed rates up to 2 mm per tooth / con avanzamenti fino a 2 mm per tagliente!

2

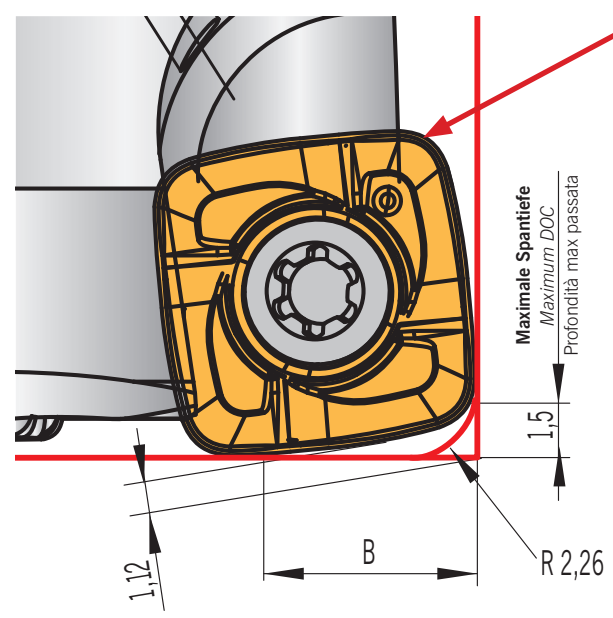

Markierung:
Um einen optimalen Plan- und Rundlauf zu erzielen, sollte die Wendeschneidplatte in jedem Sitz mit gleicher Einbaulage montiert werden. Drehung nach Verschleiß immer im Uhrzeigersinn.

Marking:
In order to achieve the optimum axial and radial runout always mount indexable inserts in same position. When worn always turn clockwise.

Marcatura inserto:
Per ottenere il posizionamento di tutti gli inserti riducendo al minimo errori radiali od assiali assicurarsi che tutti gli inserti vengano montati nella medesima posizione rispetto alla marcatura. Al cambio tagliente ruotare gli inserti in senso orario.

Restwerkstoff der Kontur beim Eck- und Nutfräsen.
Material left over when face and slot milling.
Materiale lasciato non lavorato in spianatura e svuotamento di cave.

Maximale Spantiefe / Maximum DOC / Profondità max passata = 1,5 mm
Programmierradius / Programming radius / Raggio programmazione = R2,26
SK-Länge / SK-length / Lunghezza tagliente = 9,6 mm
B = 7,6 mm

Duo-Mill -15 Vorschübe bis zu 2,5 mm pro Zahn

Feed rates up to 2.5 mm per tooth / con avanzamenti fino a 2,5 mm per tagliente!

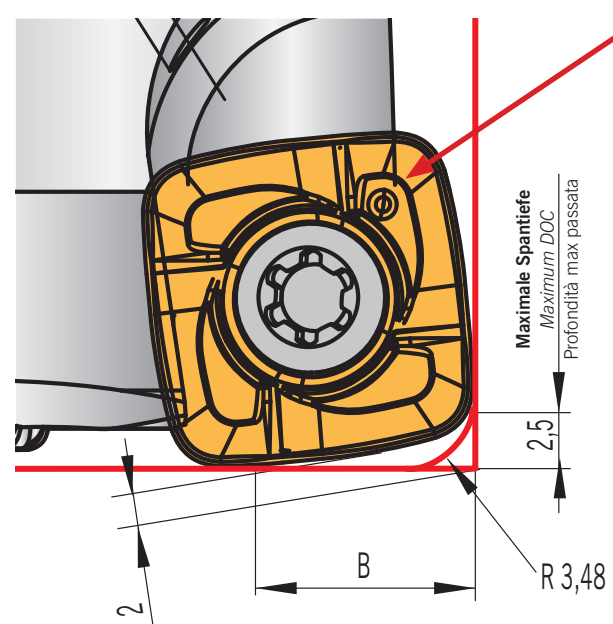

Markierung:
Um einen optimalen Plan- und Rundlauf zu erzielen, sollte die Wendeschneidplatte in jedem Sitz mit gleicher Einbaulage montiert werden. Drehung nach Verschleiß immer im Uhrzeigersinn.

Marking:
In order to achieve the optimum axial and radial runout always mount indexable inserts in same position. When worn always turn clockwise.

Marcatura inserto:
Per ottenere il posizionamento di tutti gli inserti riducendo al minimo errori radiali od assiali assicurarsi che tutti gli inserti vengano montati nella medesima posizione rispetto alla marcatura. Al cambio tagliente ruotare gli inserti in senso orario.

Restwerkstoff der Kontur beim Eck- und Nutfräsen.
Material left over when face and slot milling.
Materiale lasciato non lavorato in spianatura e svuotamento di cave.

Maximale Spantiefe / Maximum DOC / Profondità max passata = 2,5 mm
Programmierradius / Programming radius / Raggio programmazione = R3,48
SK-Länge / SK-length / Lunghezza tagliente = 14,20 mm
B = 11,00 mm

HFC-Fräsen Berechnungsformel der Schnittbreite für ebene Flächen:

HFC-milling calculation formula for cutting widths on plain surfaces:

Formula di calcolo per la larghezza di taglio su superficie piana con fresatura ad alto avanzamento:

$d_1 - 2 \times B =$
Schnittbreite / Cutting width / profondità passata X [mm]

<p>Beispiel / Example / Esempio Duo-Mill -10 – Fräser / Cutter / Fresatura D80: Durchmesser / Diameter / Diametro $d_1 = 25 \text{ mm} - 160 \text{ mm}$ B = 7,6 mm $80 \text{ mm} - (2 \times 7,6 \text{ mm}) = 64,8 \text{ mm}$</p>	<p>Beispiel / Example / Esempio Duo-Mill -15 – Fräser / Cutter / Fresatura D80: Durchmesser / Diameter / Diametro $d_1 = 25 \text{ mm} - 160 \text{ mm}$ B = 11,00 mm $80 \text{ mm} - (2 \times 11,00 \text{ mm}) = 58 \text{ mm}$</p>
--	--

Vorteile HFC-Fräsen:

- sehr hohe Abtragsraten und extrem leichter Schnitt
- maximale Prozesssicherheit im unterbrochenen Schnitt durch sichere Positionierung der Wendeschneidplatte
- Schonung der Maschinenspindel durch geringe Umschlingung der Wendeschneidplatte (Radialkräfte werden minimiert)

Advantages HFC-milling:

- Very high removal rates and extremely soft cutting
- Maximum process reliability during interrupted cut due to the secure positioning of the indexable insert
- Preserving of the machine spindle because of reduced circumference of the indexable insert (radial powers are minimized)

Vantaggi HFC-Fresatura:

- Taglio morbido ed elevato volume di asportazione truciolo.
- Massima affidabilità di processo con taglio interrotto grazie al posizionamento rigido e sicuro dell'inserto.
- Minor sollecitazioni sul mandrino grazie alla ridotta superficie di contatto (riduzione delle forze radiali).

Einsatz-Beispiel FDC: Grundsätzlich sollte die kürzeste Ausspannlänge gewählt werden.

Application example FDC: Preferably always keep overhang as short as possible.

Esempio di applicazione FDC: Utilizzare sempre la soluzione di utensile più compatta possibile.

Werkstoff-Festigkeit Material hardness Durezza del materiale	1000 N/mm²
Vorschub pro Zahn (f_z) Feed per tooth Avanzamento per dente	0,12 mm – 0,18 mm
Schnittgeschwindigkeit (v_c) Cutting speed Velocità di taglio	100 m/min

Frässpindel / Milling adaptor / Mandrino SK50:	
Spannung mit Weldon-Aufnahme in Weldon holder Lavorazione con attacco Weldon	max. Schnitttiefe (a_p) = 4 mm max DOC max. prof. passata (a _p) = 4 mm
Spannung mit Spannzange in collet chuck Lavorazione con attacco a manicotto	max. Schnitttiefe (a_p) = 4 mm max DOC max. prof. passata (a _p) = 4 mm
Frässpindel / Milling adaptor / Mandrino SK40:	
Spannung mit Weldon-Aufnahme in Weldon holder Lavorazione con attacco Weldon	max. Schnitttiefe (a_p) = 2 mm max DOC max. prof. passata (a _p) = 2 mm
Spannung mit Spannzange in collet chuck Lavorazione con attacco a manicotto	max. Schnitttiefe (a_p) = 4 mm max DOC max. prof. passata (a _p) = 4 mm

HINWEIS:

Die Tabellenwerte sind Richtwerte. Es kann notwendig sein, die Werte den jeweiligen Bearbeitungsumständen anzupassen. Besonders folgende Einflussgrößen müssen hier berücksichtigt werden:

- Maschinenleistung
- Spindel/Aufnahme
- Ausspannlänge
- Aufspannung
- Bearbeitungsart

INFO:

The charts are recommendations only. It may be necessary to adjust the cutting data according to:

- Machine power
- Spindle and shank
- Overhang length
- Material clamping
- Component stability

NOTA:

I valori indicati in tabella sono indicativi e considerati in ottimali condizioni di lavoro.

Può essere necessario adattarli in base alle diverse condizioni di lavoro quali:

- Caratteristiche della macchina (stabilità, potenza, precisione)
- Dimensione e tipologia del mandrino
- Bloccaggio del pezzo
- Bloccaggio e dimensione dell'utensile
- Condizioni generali di lavoro

Rundum überzeugend: ARNO-Gewindefräser aus Vollhartmetall für die Bearbeitung von Stahl, Aluminium und NE-Metallen.

*Solid carbide thread mills for steel, aluminium and
none ferrous materials.*

Frese a filettare per tutti i tipi di filettature e
per lavorazione di acciai e ghise.



ARNO® VOLLHARTMETALL GEWINDEFRÄSER

TiAlN beschichtete Gewindefräser aus Feinstkorn-Hartmetall bieten Ihnen eine optimale, gleichmäßige Gewindequalität sowie eine hohe Verschleißfestigkeit.

*Fine grain solid carbide cutters with
TiAlN coating, some with through
tool coolant and chamfering edge.*

Frese a filettare in metallo duro integrale rivestite per lavorare Acciaio, ghisa, Acciaio inossidabile, leghe esotiche o refrattarie e acciai temprati fino a 50 HRC.

Weitere Vollhartmetall-Fräser finden Sie im aktuellen Tiefstpreiskatalog oder unter:

You will find more solid carbide cutters in our "Special Price" catalogue:

La gamma completa di frese in MDI è disponibile sul catalogo dedicato "Catalogo Promozione" oppure visitando il sito:

www.arno.de