

## SHARK-Drill®

- Systemvorstellung
- Bezeichnungssystem
- Werkzeugauswahl
- Trägerwerkzeuge
- Schneideinsätze
  - Sortenbeschreibung
  - Geometriebeschreibung
- Ersatzteile
- Schnittwerte
- Anwendungshinweise
- Sonderwerkzeuge

## SHARK-Drill®

- *System introduction*
- *Designation system*
- *Tool shank options*
- *Drill holder*
- *Inserts*
  - *Grade description*
  - *Geometry description*
- *Spare parts*
- *Cutting data*
- *Application reference*
- *Special tooling*

## SHARK-Drill®

- Caratteristiche del sistema
- Sistema di numerazione
- Tipologie di attacco utensile
- Corpo punta
- Inserti
  - Descrizione delle Qualità
  - Descrizione delle Geometrie
- Ricambi
- Parametri di taglio
- Suggerimenti tecnici
- Utensili speciali

30 – 31
32
33
34 – 69
70 – 93
73 – 74
72
94 – 95
96 – 107
108 – 119
120

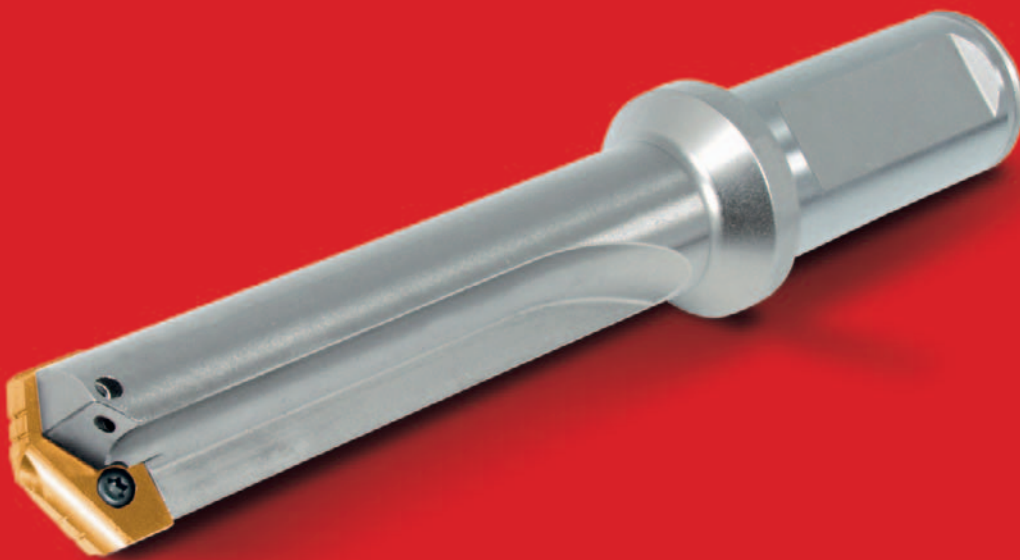

# 1

## ARNO Schneidplattenbohrer SHARK-Drill®

ARNO Flanged holders SHARK-Drill®

ARNO Corpo punta SHARK-Drill®

### 1 Alle Halter mit innerer Kühlmittelzuführung

All holders with through tool coolant supply

Passaggio interno del refrigerante su tutti i corpi

**Vernickelte Oberfläche – „Rostet nicht“. Glatte Spankammern für bessere Spanausbringung.**

*Nickel plated surface – “no rust” smooth swarf chambers for better swarf evacuation.*

Corpi con rivestimenti Nickel – resistenza alla ossidazione e migliore avacuazione truciolo.

**Spiralgenutet oder gerade genutet lieferbar.**

*Spiral or straight flutes available.*

Scarico truciolo elicoidale o diritto.

**Torx-Schrauben für einfaches und sicheres Spannen.**

*Torx screws for easy and secure locking.*

Viti Torx.

## ARNO Schneideinsatz SHARK-Drill®

ARNO Inserts SHARK-Drill®

ARNO Inserti SHARK-Drill®

### Alle Schneideinsätze sind CNC-geschliffen

All inserts are CNC ground

Inserti affilatura CNC

1

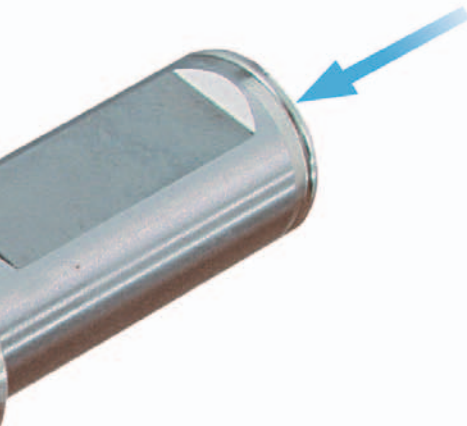

#### Ausführung mit Kühlmittelring.

Version with coolant adaptor.

Possibile adduzione tramite anello refrigerante su attacchi Cono Morse.

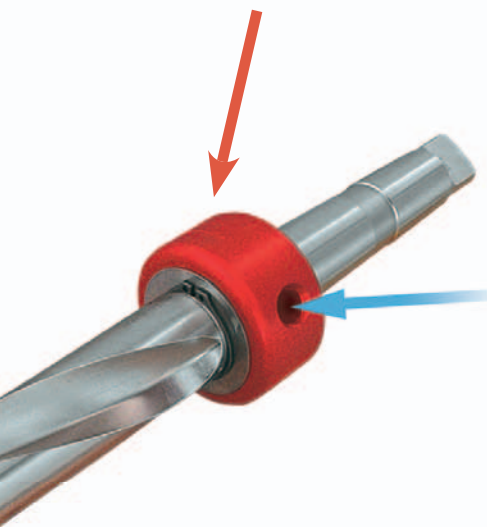

#### TiN-, TiCN- und TiAlN- Beschichtungen lieferbar. Sonderbeschichtungen auf Anfrage.

TiN-, TiCN- and TiAlN- coatings available. Special coatings on request.

Rivestimenti disponibili TiN, TiCN e TiAlN. Rivestimenti speciali a richiesta.

#### Eckenschutzfase für höhere Standzeit und Eckenstabilität.

Corner clip protection for better tool life and edge stability.

Spigoli arrotondati per una prolungata vita utensile ed una maggiore stabilità del tagliente.

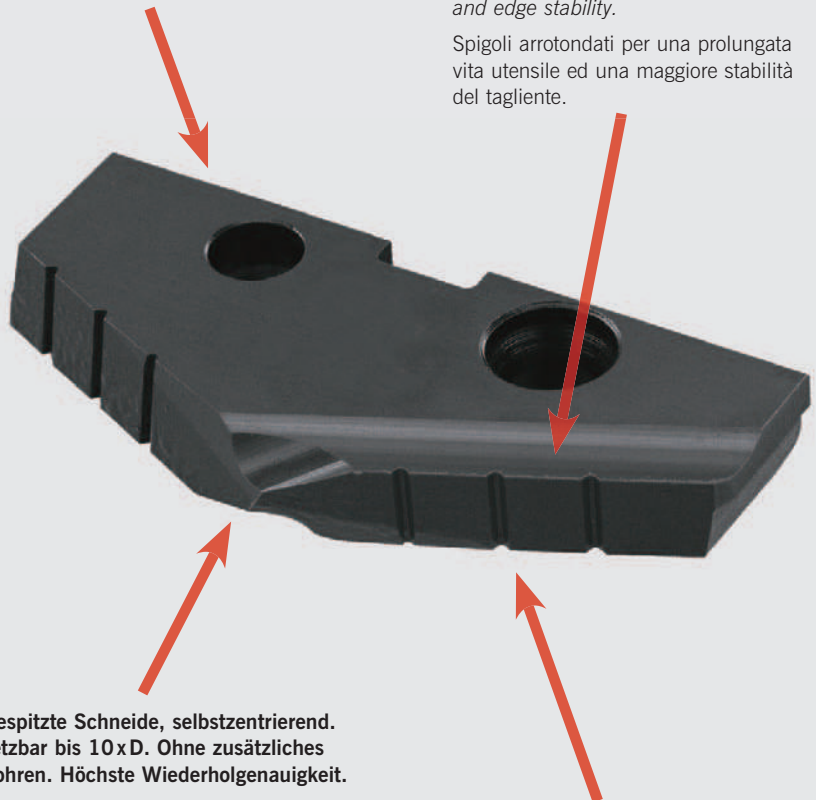

#### Ausgespitzte Schneide, selbstzentrierend. Einsetzbar bis 10xD. Ohne zusätzliches Vorbohren. Höchste Wiederholgenauigkeit.

Self-centering point allows to drill into solid up to 10xD.

L'inserto autocentrante permette di forare dal pieno fino a 10xD.

#### Spanbrecher auf allen Platten (außer für Guss bis Ø 18 mm).

Chipbreakers on all insert (except K10 up to Dia. 18 mm).

Rompitruciolo su tutti gli inserti (eccetto K10 fino a Dia 18 mm).

Schneidplatten-Bohrer / Flanged holders / Corpo punta

1



H	A	950	1107	65	SP	W 20
<b>Halter</b>	<b>Serie</b>	<b>Durchmesser von: 9,5 mm</b>	<b>Durchmesser bis: 11,07 mm</b>	<b>Maximale Bohrtiefe</b>	<b>Spankammerausführung:</b>	<b>Schafttyp:</b>
Holder	Series	Diameter from: 9.5 mm	Diameter up to: 11.07 mm	Max. drill depth	<b>SP = spiralgenutet</b>	W = DIN ISO9766 + Durchmesser
Corpo	Serie	Diametro minimo: 9,5 mm	Diametro massimo: 11,07 mm	Lunghezza utile di foratura	<b>G = gerade genutet</b>	MK = Morsekegel mit Austreiblappen + MK-Größen
	A C E G I K M O Q S U W				Flute style: SP = helical G = straight	MK -G = Morsekegel mit Austreiblappen + MK-Größe (Form BK)
					Tipo di elica: SP = spirale G = diritta	W.. -W = DIN ISO9766 + Durchmesser + Anzugsgewinde
						Shank type: W = DIN ISO9766 + Diameter MK = Morse Taper + MT size MK -G = Morse Taper + MT size (form BK) W.. -W = DIN ISO9766 + Diameter + Thread
						Attacco tipo: W = DIN ISO 9766 + Diametro MK = Cono Morse + dimensione MK -G = Cono morse + dimensione (pollici) W.. -W = DIN ISO 9766 + diametro + foro filettato

Schneideinsätze / Inserts / Inserti



P	A	9,5	HSS5	TiAIN
<b>Schneideinsatz</b>	<b>Serie</b>	<b>Durchmesser (mm)</b>	<b>HSS</b>	<b>Beschichtung</b>
Insert	Series	Diameter (mm)	= ohne Co-Gehalt	Coating
Inserto	Serie	Diametro (mm)	= without Cobalt content	Rivestimento
	A C E G I K M O Q S U W		= senza contenuto di Cobalto	
	<b>Muss immer zum Halter passen!</b> Must always be suitable to holders! Deve corrispondere al corpo punta!		<b>HSS5 = mit 5% Co-Gehalt</b> = with 5% Cobalt content = con 5% contenuto di Cobalto	
			<b>HSS8 = mit 8% Co-Gehalt</b> = with 8% Cobalt content = con 8% contenuto di Cobalto	
			<b>AP40 = P40 nach ISO</b> = P40 (ISO-Standard) = P40 (classe ISO)	
			<b>AK20 = K20 nach ISO</b> = K20 (ISO-Standard) = K20 (classe ISO)	
			<b>AK10 = K10 nach ISO</b> = K10 (ISO-Standard) = K10 (classe ISO)	

Tool shank options  
 Tipologie di attacco utensile

**Mit DIN ISO 9766-Schaft**

With DIN ISO 9766 shank

Corpo con attacco DIN ISO 9766

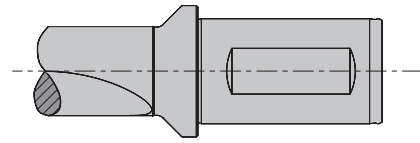

Serie Series Serie	∅ [mm]	max. Bohrtiefe [mm] max. drill depth [mm] Prof. foro max [mm]	Werkzeug auf Seite Tools on page Corpo punta a pagina	Wendeschneidplatte auf Seite Inserts on page Inserto a pagina
A	9,5–11,07	290	38 – 39	75 – 76
C	11,1–12,95	290	39 – 40	76 – 77
E	12,98–17,65	387	41 – 43	78 – 80
G	15,5–17,65	178	41/43	78 – 80
I	17,53–24,38	565	44 – 46	81 – 83
K	22,0–24,38	270	44 – 45	81 – 83
M	24,41–35,05	692	46 – 48	84 – 87
O	30,0–35,05	289	47 – 48	84 – 87
Q	34,37–47,80	787	49 – 50	88 – 89
S	46,99–65,28	879	50 – 51	90 – 91



**Mit Morsekegel**

With shank holders

Corpo con attacco Morse tipo

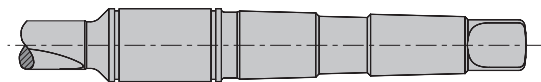

Serie Series Serie	∅ [mm]	max. Bohrtiefe [mm] max. drill depth [mm] Prof. foro max [mm]	Werkzeug auf Seite Tools on page Corpo punta a pagina	Wendeschneidplatte auf Seite Inserts on page Inserto a pagina
A	9,5–11,07	290	52 – 53	75 – 76
C	11,1–12,95	290	53 – 54	76 – 77
E	12,98–17,65	387	55 – 57	78 – 80
G	15,5–17,65	178	55 – 56	78 – 80
I	17,53–24,38	565	57 – 59	81 – 83
K	22,0–24,38	270	58 – 60	81 – 83
M	24,41–35,05	692	60 – 62	84 – 87
O	30,0–35,05	289	61 – 62	84 – 87
Q	34,37–47,80	787	63 – 64	88 – 89
S	46,99–65,28	879	65 – 66	90 – 91
U	62,38–89,08	889	66 – 67	92
W	46,99–65,28	939	68 – 69	93

**Optional mit Morsekegel (-G)  
 Erweiterte DIN 228 Form BK**

Optional with morse taper (-G)  
 for DIN 228 form BK

Corpo con attacco Morse (-G)  
 tipo DIN 228 forma BK

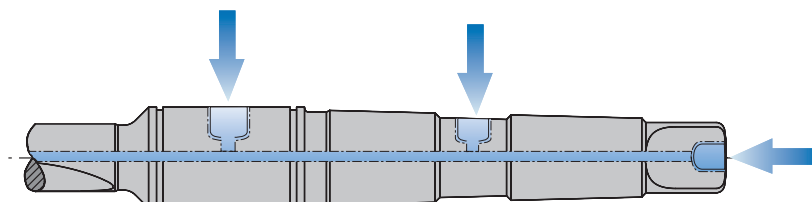

**Optional mit DIN ISO 9766-Schaft (-W)  
 und rückseitigem Gewinde nach BSP ISO 7-1**

Optional with DIN ISO 9766 shank (-W)  
 for threaded coolant connection to BSP ISO 7-1

Versione corpi (-W)  
 con foro filettato BSP ISO 7-1

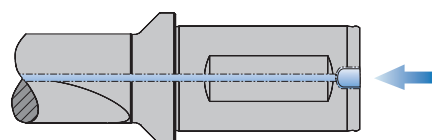

Schneidplatten-Bohrer mit DIN ISO 9766-Schaft

Flanged holders – DIN ISO 9766  
Corpo punta – Attacco DIN ISO 9766

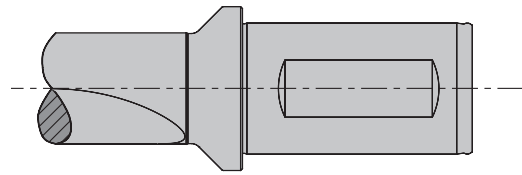

1

**Serie / Series / Serie A**  
Ø 9,5 mm – Ø 11,0 mm

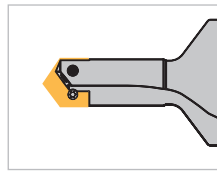

**Zylinderschaft – gerade genutet**  
Straight cylindrical shank – straight flute  
Attacco cilindrico – elica diritta

Seite 38 – 39  
Page  
Pagina

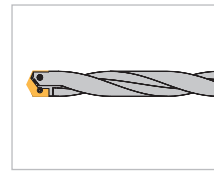

**Zylinderschaft – spiralgenutet**  
Straight cylindrical shank – helical flute  
Attacco cilindrico – elica a spirale

Seite 38  
Page  
Pagina

**Serie / Series / Serie C**  
Ø 11,5 mm – Ø 12,8 mm

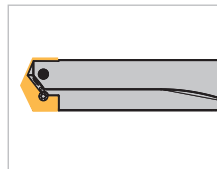

**Zylinderschaft – gerade genutet**  
Straight cylindrical shank – straight flute  
Attacco cilindrico – elica diritta

Seite 39 – 40  
Page  
Pagina

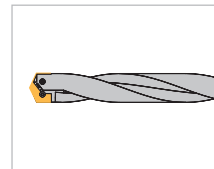

**Zylinderschaft – spiralgenutet**  
Straight cylindrical shank – helical flute  
Attacco cilindrico – elica a spirale

Seite 40  
Page  
Pagina

**Serie / Series / Serie E+G**  
Ø 13,0 mm – Ø 17,5 mm

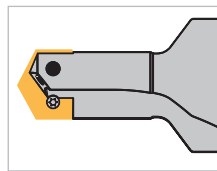

**Zylinderschaft – gerade genutet**  
Straight cylindrical shank – straight flute  
Attacco cilindrico – elica diritta

Seite 41/43  
Page  
Pagina

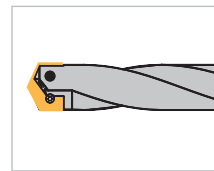

**Zylinderschaft – spiralgenutet**  
Straight cylindrical shank – helical flute  
Attacco cilindrico – elica a spirale

Seite 42 – 43  
Page  
Pagina

**Serie / Series / Serie I+K**  
Ø 17,8 mm – Ø 24,0 mm

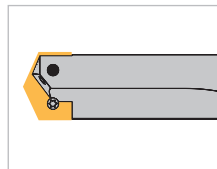

**Zylinderschaft – gerade genutet**  
Straight cylindrical shank – straight flute  
Attacco cilindrico – elica diritta

Seite 44/46  
Page  
Pagina

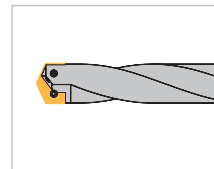

**Zylinderschaft – spiralgenutet**  
Straight cylindrical shank – helical flute  
Attacco cilindrico – elica a spirale

Seite 45  
Page  
Pagina

**Serie / Series / Serie M+O**  
Ø 24,5 mm – Ø 35,0 mm

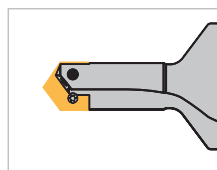

**Zylinderschaft – gerade genutet**  
Straight cylindrical shank – straight flute  
Attacco cilindrico – elica diritta

Seite 46 – 48  
Page  
Pagina

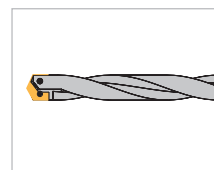

**Zylinderschaft – spiralgenutet**  
Straight cylindrical shank – helical flute  
Attacco cilindrico – elica a spirale

Seite 47 – 48  
Page  
Pagina

**Schneidplatten-Bohrer mit DINISO9766-Schaft**

Flanged holders – DINISO9766 shank  
Corpo punta – Attacco DINISO9766

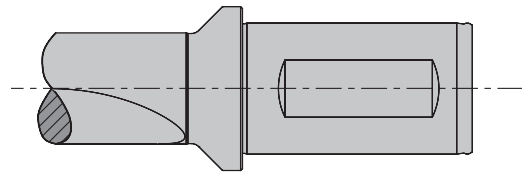

**Serie / Series / Serie Q**  
Ø 36,0 mm – Ø 47,0 mm

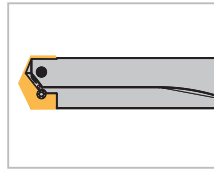

**Zylinderschaft – gerade genutet**  
Straight cylindrical shank – straight flute  
Attacco cilindrico – elica diritta

Seite 49 – 50  
Page  
Pagina

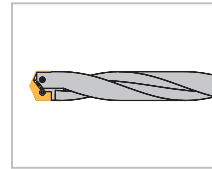

**Zylinderschaft – spiralgenutet**  
Straight cylindrical shank – helical flute  
Attacco cilindrico – elica a spirale

Seite 49  
Page  
Pagina

**Serie / Series / Serie S**  
Ø 48,0 mm – Ø 65,0 mm

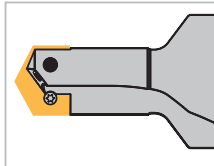

**Zylinderschaft – gerade genutet**  
Straight cylindrical shank – straight flute  
Attacco cilindrico – elica diritta

Seite 50 – 51  
Page  
Pagina

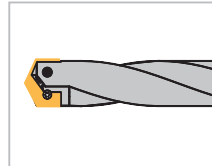

**Zylinderschaft – spiralgenutet**  
Straight cylindrical shank – helical flute  
Attacco cilindrico – elica a spirale

Seite 51  
Page  
Pagina



## Schneidplatten-Bohrer mit Morsekegel

Taper shank holders  
Corpo con Cono Morse

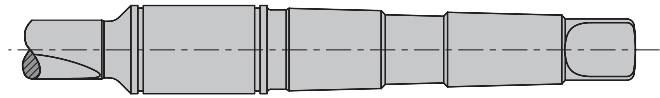

1

**Serie / Series / Serie A**  
Ø 9,5 mm – Ø 11,0 mm

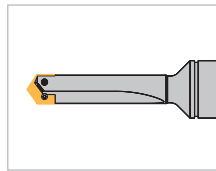

**Morsekegelschaft – gerade genutet**  
Taper shank – straight flute  
Attacco Cono Morse – elica diritta

Seite 52  
Page  
Pagina

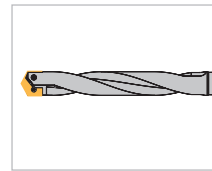

**Morsekegelschaft – spiralgenutet**  
Taper shank – helical flute  
Attacco Cono Morse – elica a spirale

Seite 52 – 53  
Page  
Pagina

**Serie / Series / Serie C**  
Ø 11,5 mm – Ø 12,8 mm

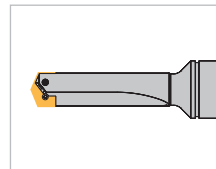

**Morsekegelschaft – gerade genutet**  
Taper shank – straight flute  
Attacco Cono Morse – elica diritta

Seite 53  
Page  
Pagina

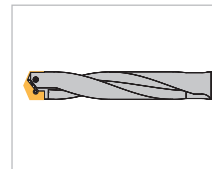

**Morsekegelschaft – spiralgenutet**  
Taper shank – helical flute  
Attacco Cono Morse – elica a spirale

Seite 54  
Page  
Pagina

**Serie / Series / Serie E+G**  
Ø 13,0 mm – Ø 17,5 mm

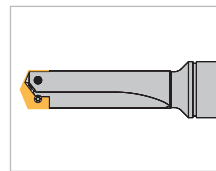

**Morsekegelschaft – gerade genutet**  
Taper shank – straight flute  
Attacco Cono Morse – elica diritta

Seite 55  
Page  
Pagina

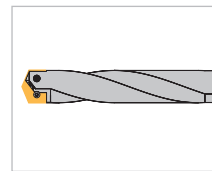

**Morsekegelschaft – spiralgenutet**  
Taper shank – helical flute  
Attacco Cono Morse – elica a spirale

Seite 56 – 57  
Page  
Pagina

**Serie / Series / Serie I+K**  
Ø 17,8 mm – Ø 24,0 mm

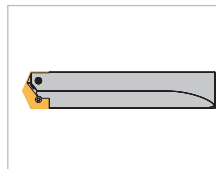

**Morsekegelschaft – gerade genutet**  
Taper shank – straight flute  
Attacco Cono Morse – elica diritta

Seite 57 – 58  
Page  
Pagina

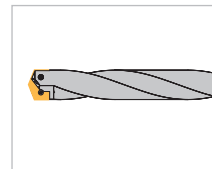

**Morsekegelschaft – spiralgenutet**  
Taper shank – helical flute  
Attacco Cono Morse – elica a spirale

Seite 58 – 60  
Page  
Pagina

**Serie / Series / Serie M+O**  
Ø 24,5 mm – Ø 35,0 mm

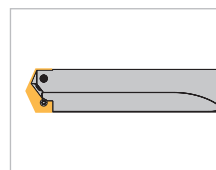

**Morsekegelschaft – gerade genutet**  
Taper shank – straight flute  
Attacco Cono Morse – elica diritta

Seite 60 – 61  
Page  
Pagina

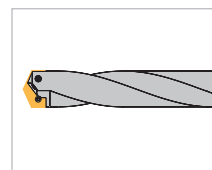

**Morsekegelschaft – spiralgenutet**  
Taper shank – helical flute  
Attacco Cono Morse – elica a spirale

Seite 61 – 62  
Page  
Pagina



## Schneidplatten-Bohrer mit Morsekegel

Taper shank holders  
Corpo con Cono Morse

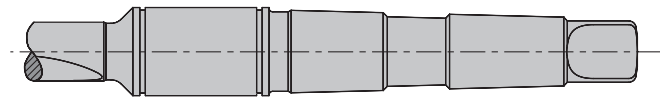

**Serie / Series / Serie Q**  
Ø 36,0 mm – Ø 47,0 mm

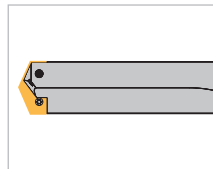

**Morsekegelschaft – gerade genutet**  
Taper shank – straight flute  
Attacco Cono Morse – elica dritta

Seite 63 – 64  
Page  
Pagina

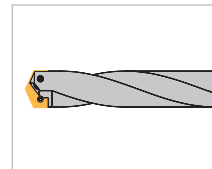

**Morsekegelschaft – spiralgenutet**  
Taper shank – helical flute  
Attacco Cono Morse – elica a spirale

Seite 63 – 64  
Page  
Pagina

**Serie / Series / Serie S**  
Ø 48,0 mm – Ø 65,0 mm

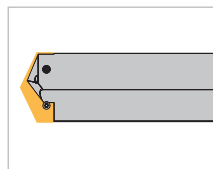

**Morsekegelschaft – gerade genutet**  
Taper shank – straight flute  
Attacco Cono Morse – elica dritta

Seite 65 – 66  
Page  
Pagina

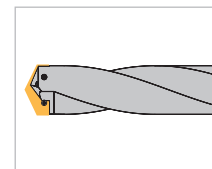

**Morsekegelschaft – spiralgenutet**  
Taper shank – helical flute  
Attacco Cono Morse – elica a spirale

Seite 65  
Page  
Pagina

**Serie / Series / Serie U**  
Ø 66,0 mm – Ø 89,0 mm

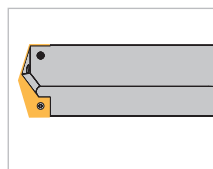

**Morsekegelschaft – gerade genutet**  
Taper shank – straight flute  
Attacco Cono Morse – elica dritta

Seite 66 – 67  
Page  
Pagina

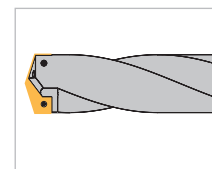

**Morsekegelschaft – spiralgenutet**  
Taper shank – helical flute  
Attacco Cono Morse – elica a spirale

Seite 67  
Page  
Pagina

**Serie / Series / Serie W**  
Ø 90,0 mm – Ø 114,0 mm

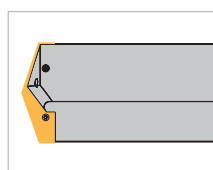

**Morsekegelschaft – gerade genutet**  
Taper shank – straight flute  
Attacco Cono Morse – elica dritta

Seite 68 – 69  
Page  
Pagina

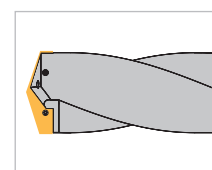

**Morsekegelschaft – spiralgenutet**  
Taper shank – helical flute  
Attacco Cono Morse – elica a spirale

Seite 68  
Page  
Pagina

1

# Schneidplatten-Bohrer mit DIN ISO 9766-Schaft

Flanged holders - DIN ISO 9766 shank  
Corpo punta - Attacco DIN ISO 9766

## Serie / Series / Serie

**A**

Ø 9,5 mm – 11,07 mm  
1,5 x D – 3 x D

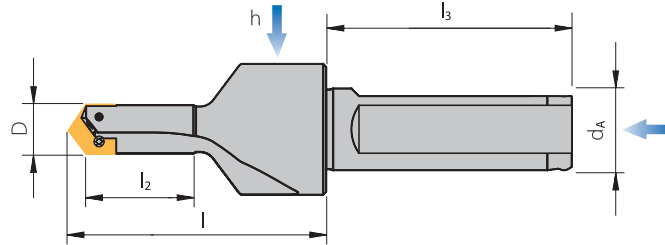
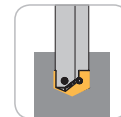
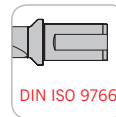

### Trägerwerkzeug / Drill holder / Corpo punta

Bezeichnung Designation Articolo	Bohrtiefe Drill depth Profondità foratura	D	l	l <sub>2</sub>	l <sub>3</sub>	h	d <sub>A</sub>	MK	Gewinde Thread Filetato
HA950-1107-19GW16	1,5 x D – 2 x D	9,5 – 11,07	50	19	41,9	1/8"	16	-	-
HA950-1107-32GW20	2,5 x D – 3 x D	9,5 – 11,07	63,5	32	41,9	-	20	-	-

Verschlussschraube 20906-G1/8  
Grub screw 20906-G1/8  
Tappo filetato 20906-G1/8

**HINWEIS:** Trägerwerkzeuge werden mit Klemmschrauben, 2 Ersatzschrauben und Schlüssel geliefert.

**INFORMATION:** Holders will be supplied with clamping screws, 2 spare screws and key.

**NOTA:** L'utensile é fornito completo di 1 vite, 2 viti di ricambio e 1 chiave.

## Serie / Series / Serie

**A**

Ø 9,5 mm – 11,07 mm  
5 x D – 11,5 x D

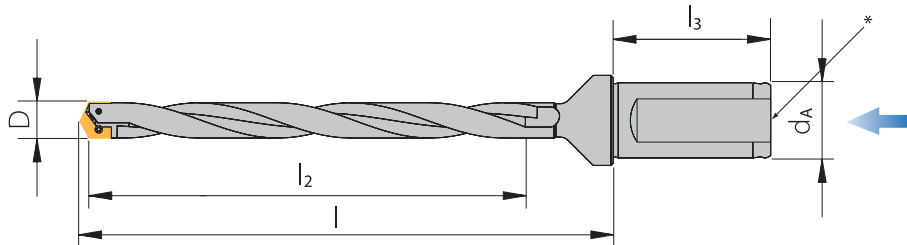
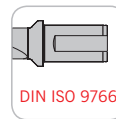

\* Gewinde G 1/8"  
Thread  
Filetato -W

### Trägerwerkzeug / Drill holder / Corpo punta

Bezeichnung Designation Articolo	Bohrtiefe Drill depth Profondità foratura	D	l	l <sub>2</sub>	l <sub>3</sub>	h	d <sub>A</sub>	MK	Gewinde Thread Filetato
HA950-1107-60SPW20	5 x D – 6 x D	9,5 – 11,07	91,1	60	41,9	-	20	-	-
HA950-1107-86SPW20	7,5 x D – 9 x D	9,5 – 11,07	118,0	86	41,9	-	20	-	-
HA950-1107-111SPW20	10 x D – 11,5 x D	9,5 – 11,07	142,9	111	41,9	-	20	-	-
HA950-1107-111SPW20-W	10 x D – 11,5 x D	9,5 – 11,07	142,9	111	41,9	-	20	-	G 1/8"

**HINWEIS:** Trägerwerkzeuge werden mit Klemmschrauben, 2 Ersatzschrauben und Schlüssel geliefert.

**INFORMATION:** Holders will be supplied with clamping screws, 2 spare screws and key.

**NOTA:** L'utensile é fornito completo di 1 vite, 2 viti di ricambio e 1 chiave.

Zubehör für Bohrer siehe Seite 94 – 95.

**Hinweis:** Beachten Sie bitte die Anwendungshinweise zu diesen Haltern ab Seite 109!

Holder accessories see page 94 – 95.

Remark: Please see the application guidelines for this holder on page 109!

Accessori corpo a pagina 94 – 95.

Attenzione: Note di utilizzo per questo tipo di utensile a pagina 109!

# Schneidplatten-Bohrer mit DIN ISO 9766-Schaft

Flanged holders - DIN ISO 9766 shank  
Corpo punta - Attacco DIN ISO 9766

## Serie / Series / Serie

**A**  
Ø 9,5 mm – 11,07 mm  
20 x D – 30,5 x D

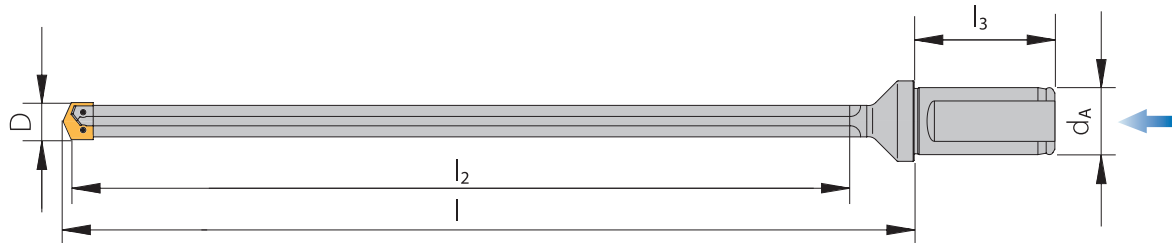

## Trägerwerkzeug / Drill holder / Corpo punta

Bezeichnung Designation Articolo	Bohrtiefe Drill depth Profondità foratura	D	l	l <sub>2</sub>	l <sub>3</sub>	h	d <sub>A</sub>	MK	Gewinde Thread Filetato
HA950-1107-222GW20	20 x D – 23 x D	9,5 – 11,07	254,1	222	41,9	-	20	-	-
HA950-1107-290GW20	26 x D – 30,5 x D	9,5 – 11,07	322,3	290	41,9	-	20	-	-

**HINWEIS:** Trägerwerkzeuge werden mit Klemmschrauben, 2 Ersatzschrauben und Schlüssel geliefert.  
**INFORMATION:** Holders will be supplied with clamping screws, 2 spare screws and key.  
**NOTA:** L'utensile é fornito completo di 1 vite, 2 viti di ricambio e 1 chiave.

## Serie / Series / Serie

**C**  
Ø 11,1 mm – 12,95 mm  
1 x D – 2,5 x D

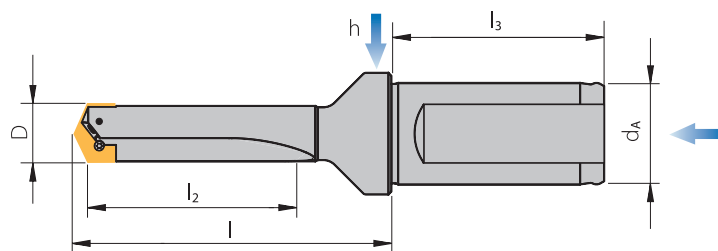

## Trägerwerkzeug / Drill holder / Corpo punta

Bezeichnung Designation Articolo	Bohrtiefe Drill depth Profondità foratura	D	l	l <sub>2</sub>	l <sub>3</sub>	h	d <sub>A</sub>	MK	Gewinde Thread Filetato
HC1110-1295-19GW16	1 x D – 1,5 x D	11,1 – 12,95	48	19	41,9	1/8"	16	-	-
HC1110-1295-32GW20	2 x D – 2,5 x D	11,1 – 12,95	63,5	32	41,9	-	20	-	-

Verschlusschraube 20906-G1/8  
Grub screw 20906-G1/8  
Tappo filettato 20906-G1/8

**HINWEIS:** Trägerwerkzeuge werden mit Klemmschrauben, 2 Ersatzschrauben und Schlüssel geliefert.  
**INFORMATION:** Holders will be supplied with clamping screws, 2 spare screws and key.  
**NOTA:** L'utensile é fornito completo di 1 vite, 2 viti di ricambio e 1 chiave.

Zubehör für Bohrer siehe Seite 94 – 95.

**Hinweis:** Beachten Sie bitte die Anwendungshinweise zu diesen Haltern ab Seite 109!

Holder accessories see page 94 – 95.

Remark: Please see the application guidelines for this holder on page 109!

Accessori corpo a pagina 94 – 95.

Attenzione: Note di utilizzo per questo tipo di utensile a pagina 109!

# Schneidplatten-Bohrer mit DIN ISO 9766-Schaft

Flanged holders - DIN ISO 9766 shank

Corpo punta - Attacco DIN ISO 9766

## Serie / Series / Serie

**C**

Ø 11,1 mm – 12,95 mm

4,5 x D – 16 x D

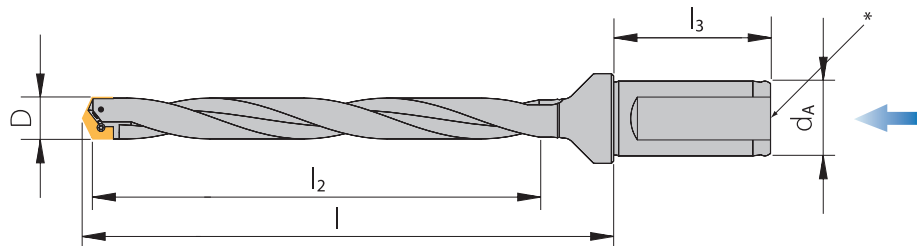
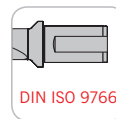

\* Gewinde G 1/8"  
Thread  
Filetato -W

## Trägerwerkzeug / Drill holder / Corpo punta

Bezeichnung Designation Articolo	Bohrtiefe Drill depth Profondità foratura	D	l	l <sub>2</sub>	l <sub>3</sub>	h	d <sub>A</sub>	MK	Gewinde Thread Filetato
HC1110-1295-60SPW20	4,5 x D – 5 x D	11,1 – 12,95	92,1	60	41,9	-	20	-	-
HC1110-1295-60SPW20-W	4,5 x D – 5 x D	11,1 – 12,95	92,1	60	41,9	-	20	-	G 1/8"
HC1110-1295-86SPW20	6,5 x D – 7,5 x D	11,1 – 12,95	118,0	86	41,9	-	20	-	-
HC1110-1295-111SPW20	8,5 x D – 10 x D	11,1 – 12,95	142,9	111	41,9	-	20	-	-
HC1110-1295-111SPW20-W	8,5 x D – 10 x D	11,1 – 12,95	142,9	111	41,9	-	20	-	G 1/8"
HC1110-1295-180SPW20	13,5 x D – 16 x D	11,1 – 12,95	212,0	180	41,9	-	20	-	-

**HINWEIS:** Trägerwerkzeuge werden mit Klemmschrauben, 2 Ersatzschrauben und Schlüssel geliefert.

**INFORMATION:** Holders will be supplied with clamping screws, 2 spare screws and key.

**NOTA:** L'utensile é fornito completo di 1 vite, 2 viti di ricambio e 1 chiave.

## Serie / Series / Serie

**C**

Ø 11,1 mm – 12,95 mm

17 x D – 26 x D

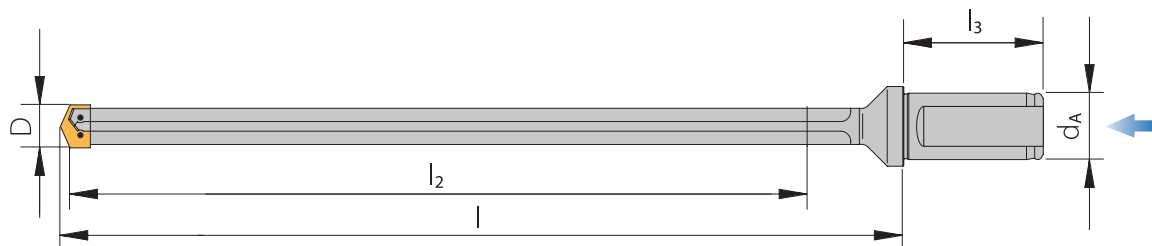

## Trägerwerkzeug / Drill holder / Corpo punta

Bezeichnung Designation Articolo	Bohrtiefe Drill depth Profondità foratura	D	l	l <sub>2</sub>	l <sub>3</sub>	h	d <sub>A</sub>	MK	Gewinde Thread Filetato
HC1110-1295-222GW20	17 x D – 20 x D	11,1 – 12,95	254,1	222	41,9	-	20	-	-
HC1110-1295-290GW20	22 x D – 26 x D	11,1 – 12,95	322,3	290	41,9	-	20	-	-

**HINWEIS:** Trägerwerkzeuge werden mit Klemmschrauben, 2 Ersatzschrauben und Schlüssel geliefert.

**INFORMATION:** Holders will be supplied with clamping screws, 2 spare screws and key.

**NOTA:** L'utensile é fornito completo di 1 vite, 2 viti di ricambio e 1 chiave.

# Schneidplatten-Bohrer mit DIN ISO 9766-Schaft

Flanged holders - DIN ISO 9766 shank  
Corpo punta - Attacco DIN ISO 9766

## Serie / Series / Serie

**E**

Ø 12,98 mm – 17,65 mm  
1 x D – 2,5 x D

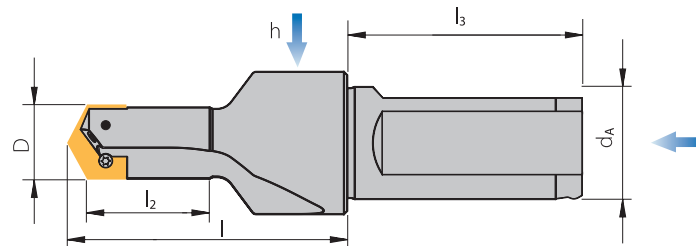
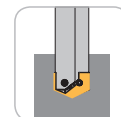

### Trägerwerkzeug / Drill holder / Corpo punta

Bezeichnung Designation Articolo	Bohrtiefe Drill depth Profondità foratura	D	l	l <sub>2</sub>	l <sub>3</sub>	h	d <sub>A</sub>	MK	Gewinde Thread Filetato
HE1298-1765-22GW20	1 x D – 1,5 x D	12,98 – 17,65	50,4	22	41,9	1/8"	20	-	-
HE1298-1765-35GW20	1,5 x D – 2,5 x D	12,98 – 17,65	66,3	35	41,9	-	20	-	-

**HINWEIS:** Trägerwerkzeuge werden mit Klemmschrauben, 2 Ersatzschrauben und Schlüssel geliefert.  
**INFORMATION:** Holders will be supplied with clamping screws, 2 spare screws and key.  
**NOTA:** L'utensile é fornito completo di 1 vite, 2 viti di ricambio e 1 chiave.

## Serie / Series / Serie

**G**

Ø 15,5 mm – 17,65 mm  
1 x D – 2 x D

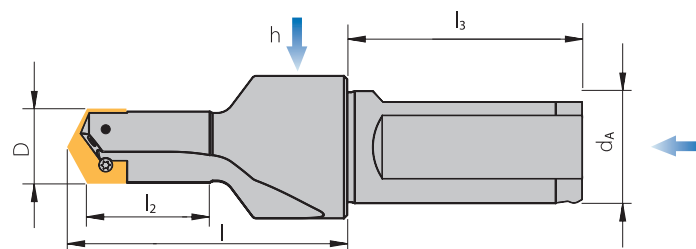
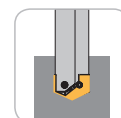

### Trägerwerkzeug / Drill holder / Corpo punta

Bezeichnung Designation Articolo	Bohrtiefe Drill depth Profondità foratura	D	l	l <sub>2</sub>	l <sub>3</sub>	h	d <sub>A</sub>	MK	Gewinde Thread Filetato
HG1550-1765-22GW20	1 x D – 1,5 x D	15,5 – 17,65	50,4	22	41,9	1/8"	20	-	-
HG1550-1765-35GW20	1,5 x D – 2 x D	15,5 – 17,65	66,3	35	41,9	-	20	-	-

Verschlusschraube 20906-G1/8  
Grub screw 20906-G1/8  
Tappo filettato 20906-G1/8

**HINWEIS:** Trägerwerkzeuge werden mit Klemmschrauben, 2 Ersatzschrauben und Schlüssel geliefert.  
**INFORMATION:** Holders will be supplied with clamping screws, 2 spare screws and key.  
**NOTA:** L'utensile é fornito completo di 1 vite, 2 viti di ricambio e 1 chiave.

Zubehör für Bohrer siehe Seite 94 – 95.

Hinweis: Beachten Sie bitte die Anwendungshinweise zu diesen Haltern ab Seite 109!

Holder accessories see page 94 – 95.

Remark: Please see the application guidelines for this holder on page 109!

Accessori corpo a pagina 94 – 95.

Attenzione: Note di utilizzo per questo tipo di utensile a pagina 109!

# Schneidplatten-Bohrer mit DIN ISO 9766-Schaft

Flanged holders - DIN ISO 9766 shank

Corpo punta - Attacco DIN ISO 9766

## Serie / Series / Serie

**E**

Ø 12,98 mm – 17,65 mm

3,5 x D – 18 x D

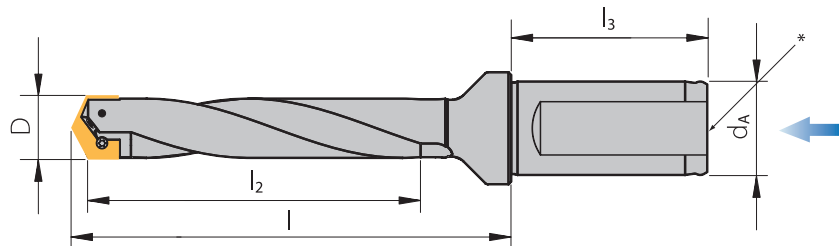

\* Gewinde G 1/8"  
Thread  
Filetato -W

## Trägerwerkzeug / Drill holder / Corpo punta

Bezeichnung Designation Articolo	Bohrtiefe Drill depth Profondità foratura	D	l	l <sub>2</sub>	l <sub>3</sub>	h	d <sub>A</sub>	MK	Gewinde Thread Filetato
HE1298-1765-64SPW20	3,5 x D – 4,5 x D	12,98 – 17,65	94,9	64	41,9	-	20	-	-
HE1298-1765-64SPW20-W	3,5 x D – 4,5 x D	12,98 – 17,65	94,9	64	41,9	-	20	-	G 1/8"
HE1298-1765-89SPW20	5 x D – 6,5 x D	12,98 – 17,65	120,0	89	41,9	-	20	-	-
HE1298-1765-114SPW20	6 x D – 8,5 x D	12,98 – 17,65	145,7	114	41,9	-	20	-	-
HE1298-1765-114SPW20-W	6 x D – 8,5 x D	12,98 – 17,65	145,7	114	41,9	-	20	-	G 1/8"
HE1298-1765-178SPW20	10 x D – 13,5 x D	12,98 – 17,65	209,1	178	41,9	-	20	-	-
HE1298-1765-178SPW20-W	10 x D – 13,5 x D	12,98 – 17,65	209,1	178	41,9	-	20	-	G 1/8"
HE1298-1765-240SPW20	13,5 x D – 18 x D	12,98 – 17,65	271,0	240	41,9	-	20	-	-

**HINWEIS:** Trägerwerkzeuge werden mit Klemmschrauben, 2 Ersatzschrauben und Schlüssel geliefert.

**INFORMATION:** Holders will be supplied with clamping screws, 2 spare screws and key.

**NOTA:** L'utensile é fornito completo di 1 vite, 2 viti di ricambio e 1 chiave.

Zubehör für Bohrer siehe Seite 94 – 95.

Hinweis: Beachten Sie bitte die Anwendungshinweise zu diesen Haltern ab Seite 109!

Holder accessories see page 94 – 95.

Remark: Please see the application guidelines for this holder on page 109!

Accessori corpo a pagina 94 – 95.

Attenzione: Note di utilizzo per questo tipo di utensile a pagina 109!

# Schneidplatten-Bohrer mit DIN ISO 9766-Schaft

Flanged holders - DIN ISO 9766 shank  
Corpo punta - Attacco DIN ISO 9766

## Serie / Series / Serie

**G**

Ø 15,5 mm – 17,65 mm  
3,5 x D – 11 x D

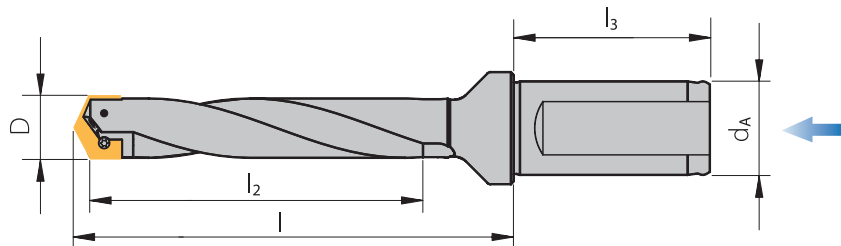

## Trägerwerkzeug / Drill holder / Corpo punta

Bezeichnung Designation Articolo	Bohrtiefe Drill depth Profondità foratura	D	l	l <sub>2</sub>	l <sub>3</sub>	h	d <sub>A</sub>	MK	Gewinde Thread Filetato
HG1550-1765-64SPW20	3,5 x D – 4 x D	15,5 – 17,65	94,9	64	41,9	-	20	-	-
HG1550-1765-114SPW20	6 x D – 7 x D	15,5 – 17,65	145,7	114	41,9	-	20	-	-
HG1550-1765-178SPW20	10 x D – 11 x D	15,5 – 17,65	209,1	178	41,9	-	20	-	-

**HINWEIS:** Trägerwerkzeuge werden mit Klemmschrauben, 2 Ersatzschrauben und Schlüssel geliefert.  
**INFORMATION:** Holders will be supplied with clamping screws, 2 spare screws and key.  
**NOTA:** L'utensile é fornito completo di 1 vite, 2 viti di ricambio e 1 chiave.

## Serie / Series / Serie

**E**

Ø 12,98 mm – 17,65 mm  
16,5 x D – 29,5 x D

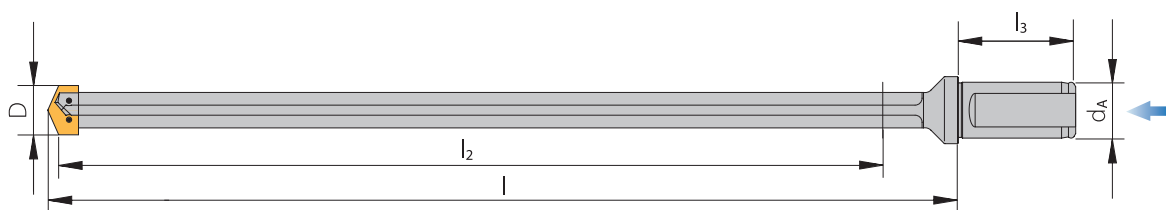

## Trägerwerkzeug / Drill holder / Corpo punta

Bezeichnung Designation Articolo	Bohrtiefe Drill depth Profondità foratura	D	l	l <sub>2</sub>	l <sub>3</sub>	h	d <sub>A</sub>	MK	Gewinde Thread Filetato
HE1298-1765-295GW20	16,5 x D – 22,5 x D	12,98 – 17,65	326,7	295	41,9	-	20	-	-
HE1298-1765-387GW20	21,5 x D – 29,5 x D	12,98 – 17,65	418,8	387	41,9	-	20	-	-

**HINWEIS:** Trägerwerkzeuge werden mit Klemmschrauben, 2 Ersatzschrauben und Schlüssel geliefert.  
**INFORMATION:** Holders will be supplied with clamping screws, 2 spare screws and key.  
**NOTA:** L'utensile é fornito completo di 1 vite, 2 viti di ricambio e 1 chiave.

Zubehör für Bohrer siehe Seite 94 – 95.

Hinweis: Beachten Sie bitte die Anwendungshinweise zu diesen Haltern ab Seite 109!

Holder accessories see page 94 – 95.

Remark: Please see the application guidelines for this holder on page 109!

Accessori corpo a pagina 94 – 95.

Attenzione: Note di utilizzo per questo tipo di utensile a pagina 109!

# Schneidplatten-Bohrer mit DIN ISO 9766-Schaft

Flanged holders - DIN ISO 9766 shank  
Corpo punta - Attacco DIN ISO 9766

## Serie / Series / Serie

**I**  
Ø 17,53 mm – 24,38 mm  
1,5 x D – 3,5 x D

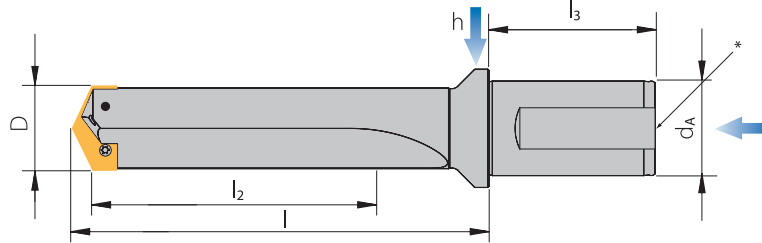
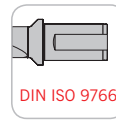

\* Gewinde G 1/8"  
Thread  
Filetato -W

### Trägerwerkzeug / Drill holder / Corpo punta

Bezeichnung Designation Articolo	Bohrtiefe Drill depth Profondità foratura	D	l	l <sub>2</sub>	l <sub>3</sub>	h	d <sub>A</sub>	MK	Gewinde Thread Filetato
HI1753-2438-47GW25	1,5 x D – 2,5 x D	17,53 – 24,38	79,4	47	53,1	1/8"	25	-	-
HI1753-2438-47GW25-W	1,5 x D – 2,5 x D	17,53 – 24,38	79,4	47	53,1	1/8"	25	-	G 1/8"
HI1753-2438-67GW25	2,5 x D – 3,5 x D	17,53 – 24,38	110,7	67	53,1	-	25	-	-
HI1753-2438-67GW25-W	2,5 x D – 3,5 x D	17,53 – 24,38	110,7	67	53,1	-	25	-	G 1/8"

**HINWEIS:** Trägerwerkzeuge werden mit Klemmschrauben, 2 Ersatzschrauben und Schlüssel geliefert.  
**INFORMATION:** Holders will be supplied with clamping screws, 2 spare screws and key.  
**NOTA:** L'utensile é fornito completo di 1 vite, 2 viti di ricambio e 1 chiave.

## Serie / Series / Serie

**K**  
Ø 22,0 mm – 24,38 mm  
2 x D – 3 x D

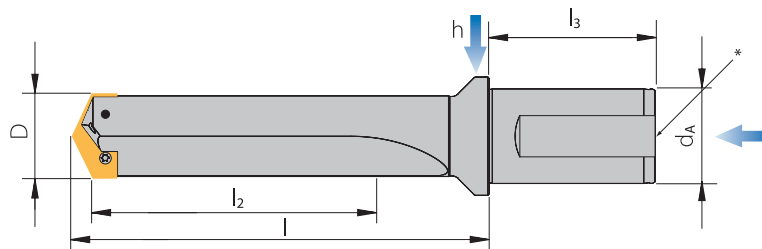

\* Gewinde G 1/8"  
Thread  
Filetato -W

### Trägerwerkzeug / Drill holder / Corpo punta

Bezeichnung Designation Articolo	Bohrtiefe Drill depth Profondità foratura	D	l	l <sub>2</sub>	l <sub>3</sub>	h	d <sub>A</sub>	MK	Gewinde Thread Filetato
HK2200-2438-57GW25	2 x D – 2,5 x D	22,0 – 24,38	92,1	57	53,1	1/8"	25	-	-
HK2200-2438-67GW25	2,5 x D – 3 x D	22,0 – 24,38	110,7	67	53,1	-	25	-	-

Verschlusschraube 20906-G1/8  
Grub screw 20906-G 1/8  
Tappo filetato 20906-G1/8

**HINWEIS:** Trägerwerkzeuge werden mit Klemmschrauben, 2 Ersatzschrauben und Schlüssel geliefert.  
**INFORMATION:** Holders will be supplied with clamping screws, 2 spare screws and key.  
**NOTA:** L'utensile é fornito completo di 1 vite, 2 viti di ricambio e 1 chiave.

**Hinweis:** Beachten Sie bitte die Anwendungshinweise zu diesen Haltern ab Seite 109!  
Holder accessories see page 94 – 95.

Remark: Please see the application guidelines for this holder on page 109!  
Accessori corpo a pagina 94 – 95.

Attenzione: Note di utilizzo per questo tipo di utensile a pagina 109!



# Schneidplatten-Bohrer mit DIN ISO 9766-Schaft

Flanged holders - DIN ISO 9766 shank

Corpo punta - Attacco DIN ISO 9766

## Serie / Series / Serie

**I**  
 Ø 17,53 mm – 24,38 mm  
 4,5 x D – 20,5 x D

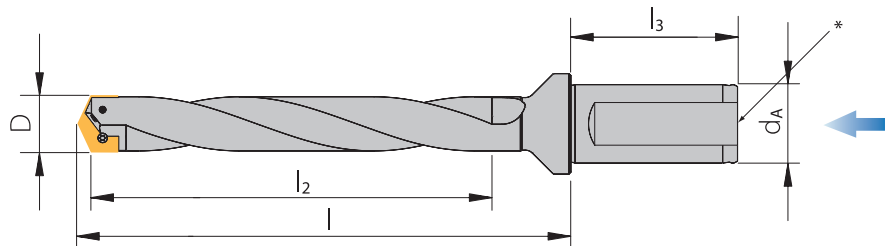

\* Gewinde G 1/8"  
 Thread  
 Filetato -W

1

## Trägerwerkzeug / Drill holder / Corpo punta

Bezeichnung Designation Articolo	Bohrtiefe Drill depth Profondità foratura	D	l	l <sub>2</sub>	l <sub>3</sub>	h	d <sub>A</sub>	MK	Gewinde Thread Filetato
HI1753-2438-118SPW25	4,5 x D – 6,5 x D	17,53 – 24,38	158,4	118	53,1	-	25	-	-
HI1753-2438-168SPW25	6,5 x D – 9,5 x D	17,53 – 24,38	209,2	168	53,1	-	25	-	-
HI1753-2438-168SPW25-W	6,5 x D – 9,5 x D	17,53 – 24,38	209,2	168	53,1	-	25	-	G 1/8"
HI1753-2438-219SPW25	8,5 x D – 12 x D	17,53 – 24,38	260,0	219	53,1	-	25	-	-
HI1753-2438-270SPW25	11 x D – 15 x D	17,53 – 24,38	310,8	270	53,1	-	25	-	-
HI1753-2438-365SPW25	14,5 x D – 20,5 x D	17,53 – 24,38	406,0	365	53,1	-	25	-	-

**HINWEIS:** Trägerwerkzeuge werden mit Klemmschrauben, 2 Ersatzschrauben und Schlüssel geliefert.

**INFORMATION:** Holders will be supplied with clamping screws, 2 spare screws and key.

**NOTA:** L'utensile é fornito completo di 1 vite, 2 viti di ricambio e 1 chiave.

## Serie / Series / Serie

**K**  
 Ø 22,0 mm – 24,38 mm  
 4,5 x D – 12 x D

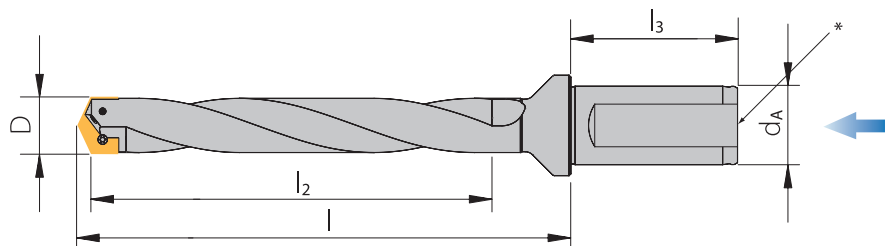

\* Gewinde G 1/8"  
 Thread  
 Filetato -W

## Trägerwerkzeug / Drill holder / Corpo punta

Bezeichnung Designation Articolo	Bohrtiefe Drill depth Profondità foratura	D	l	l <sub>2</sub>	l <sub>3</sub>	h	d <sub>A</sub>	MK	Gewinde Thread Filetato
HK2200-2438-118SPW25	4,5 x D – 5 x D	22,0 – 24,38	158,4	118	53,1	-	25	-	-
HK2200-2438-168SPW25	6,5 x D – 7,5 x D	22,0 – 24,38	209,2	168	53,1	-	25	-	-
HK2200-2438-270SPW25	11 x D – 12 x D	22,0 – 24,38	310,8	270	53,1	-	25	-	-

**HINWEIS:** Trägerwerkzeuge werden mit Klemmschrauben, 2 Ersatzschrauben und Schlüssel geliefert.

**INFORMATION:** Holders will be supplied with clamping screws, 2 spare screws and key.

**NOTA:** L'utensile é fornito completo di 1 vite, 2 viti di ricambio e 1 chiave.

# Schneidplatten-Bohrer mit DIN ISO 9766-Schaft

Flanged holders - DIN ISO 9766 shank  
Corpo punta - Attacco DIN ISO 9766

## Serie / Series / Serie

**I**  
Ø 17,53 mm – 24,38 mm  
18,5 x D – 32 x D

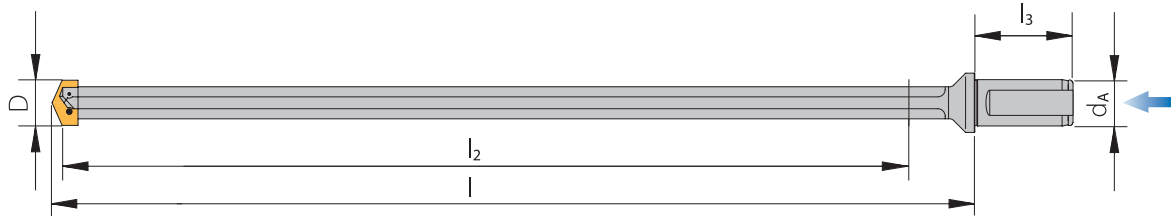

## Trägerwerkzeug / Drill holder / Corpo punta

Bezeichnung Designation Articolo	Bohrtiefe Drill depth Profondità foratura	D	l	l <sub>2</sub>	l <sub>3</sub>	h	d <sub>A</sub>	MK	Gewinde Thread Filetato
HI1753-2438-457GW25	18,5 x D – 26 x D	17,53 – 24,38	498,1	457	53,1	-	25	-	-
HI1753-2438-565GW25	23 x D – 32 x D	17,53 – 24,38	606,1	565	53,1	-	25	-	-

**HINWEIS:** Trägerwerkzeuge werden mit Klemmschrauben, 2 Ersatzschrauben und Schlüssel geliefert.  
**INFORMATION:** Holders will be supplied with clamping screws, 2 spare screws and key.  
**NOTA:** L'utensile é fornito completo di 1 vite, 2 viti di ricambio e 1 chiave.

## Serie / Series / Serie

**M**  
Ø 24,41 mm – 35,05 mm  
1,5 x D – 3,5 x D

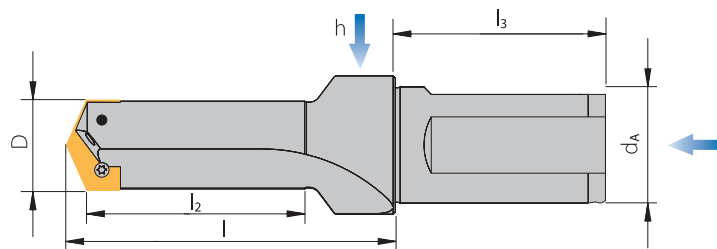

## Trägerwerkzeug / Drill holder / Corpo punta

Bezeichnung Designation Articolo	Bohrtiefe Drill depth Profondità foratura	D	l	l <sub>2</sub>	l <sub>3</sub>	h	d <sub>A</sub>	MK	Gewinde Thread Filetato
HM2441-3505-57GW32	1,5 x D – 2 x D	24,41 – 35,05	92,1	57	57,9	1/8"	32	-	-
HM2441-3505-86GW32	2 x D – 3,5 x D	24,41 – 35,05	132,2	86	57,9	-	32	-	-
HM2441-3505-86GW32-W	2 x D – 3,5 x D	24,41 – 35,05	132,2	86	57,9	-	32	-	G 1/4"

**HINWEIS:** Trägerwerkzeuge werden mit Klemmschrauben, 2 Ersatzschrauben und Schlüssel geliefert.  
**INFORMATION:** Holders will be supplied with clamping screws, 2 spare screws and key.  
**NOTA:** L'utensile é fornito completo di 1 vite, 2 viti di ricambio e 1 chiave.

Zubehör für Bohrer siehe Seite 94 – 95.  
Hinweis: Beachten Sie bitte die Anwendungshinweise zu diesen Haltern ab Seite 109!

Holder accessories see page 94 – 95.  
Remark: Please see the application guidelines for this holder on page 109!

Accessori corpo a pagina 94 – 95.  
Attenzione: Note di utilizzo per questo tipo di utensile a pagina 109!

# Schneidplatten-Bohrer mit DIN ISO 9766-Schaft

Flanged holders - DIN ISO 9766 shank

Corpo punta - Attacco DIN ISO 9766

## Serie / Series / Serie

### O

Ø 30,0 mm – 35,05 mm

2 x D – 3,5 x D

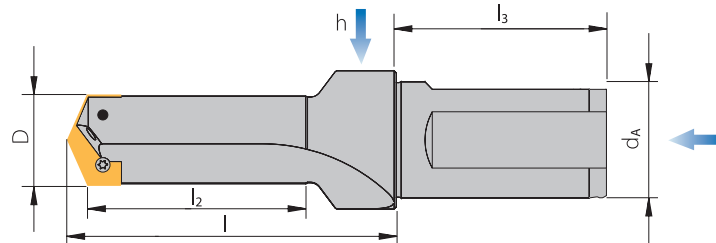
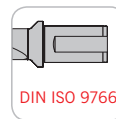

## Trägerwerkzeug / Drill holder / Corpo punta

Bezeichnung Designation Articolo	Bohrtiefe Drill depth Profondità foratura	D	l	l <sub>2</sub>	l <sub>3</sub>	h	d <sub>A</sub>	MK	Gewinde Thread Filetato
HO3000-3505-86GW32	2 x D – 3,5 x D	30,0 – 35,05	132,2	86	57,9	-	32	-	-
HO3000-3505-92GW32	2,5 x D – 3,5 x D	30,0 – 35,05	127	92	57,9	1/8"	32	-	-

Verschlussschraube 20906-G1/8  
Grub screw 20906-G1/8  
Tappo filetato 20906-G1/8

**HINWEIS:** Trägerwerkzeuge werden mit Klemmschrauben, 2 Ersatzschrauben und Schlüssel geliefert.

**INFORMATION:** Holders will be supplied with clamping screws, 2 spare screws and key.

**NOTA:** L'utensile é fornito completo di 1 vite, 2 viti di ricambio e 1 chiave.

## Serie / Series / Serie

### M

Ø 24,41 mm – 35,05 mm

3,5 x D – 16,5 x D

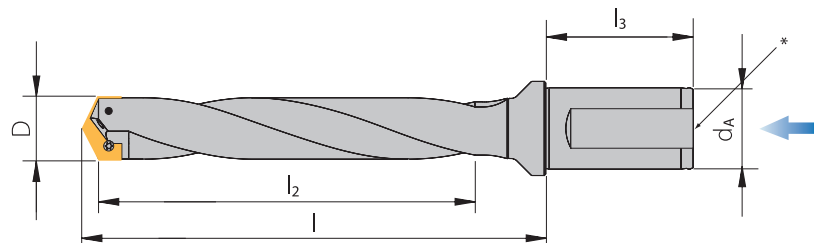

\* Gewinde G 1/4"  
Thread  
Filetato -W

## Trägerwerkzeug / Drill holder / Corpo punta

Bezeichnung Designation Articolo	Bohrtiefe Drill depth Profondità foratura	D	l	l <sub>2</sub>	l <sub>3</sub>	h	d <sub>A</sub>	MK	Gewinde Thread Filetato
HM2441-3505-137SPW32	3,5 x D – 5,5 x D	24,41 – 35,05	183,0	137	57,9	-	32	-	-
HM2441-3505-137SPW32-W	3,5 x D – 5,5 x D	24,41 – 35,05	183,0	137	57,9	-	32	G 1/4"	-
HM2441-3505-187SPW32	5 x D – 7,5 x D	24,41 – 35,05	233,8	187	57,9	-	32	-	-
HM2441-3505-187SPW32-W	5 x D – 7,5 x D	24,41 – 35,05	233,8	187	57,9	-	32	G 1/4"	-
HM2441-3505-238SPW32	6,5 x D – 9,5 x D	24,41 – 35,05	285,0	238	57,9	-	32	-	-
HM2441-3505-289SPW32	8 x D – 11,5 x D	24,41 – 35,05	335,4	289	57,9	-	32	-	-
HM2441-3505-289SPW32-W	8 x D – 11,5 x D	24,41 – 35,05	335,4	289	57,9	-	32	G 1/4"	-
HM2441-3505-410SPW32	11,5 x D – 16,5 x D	24,41 – 35,05	456,5	410	57,9	-	32	-	-

**HINWEIS:** Trägerwerkzeuge werden mit Klemmschrauben, 2 Ersatzschrauben und Schlüssel geliefert.

**INFORMATION:** Holders will be supplied with clamping screws, 2 spare screws and key.

**NOTA:** L'utensile é fornito completo di 1 vite, 2 viti di ricambio e 1 chiave.

# Schneidplatten-Bohrer mit DIN ISO 9766-Schaft

Flanged holders - DIN ISO 9766 shank  
Corpo punta - Attacco DIN ISO 9766

## Serie / Series / Serie

**O**

Ø 30,0 mm – 35,05 mm  
3,5 x D – 11,5 x D

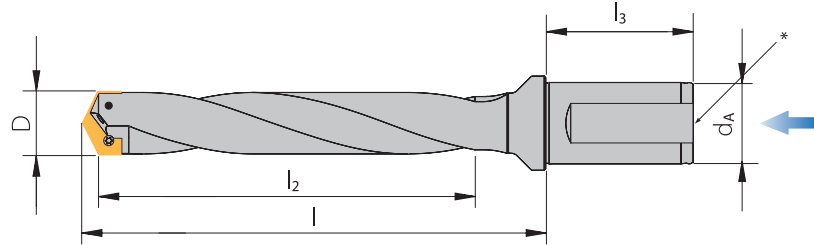

\* Gewinde G 1/4\*  
Thread  
Filetato -W

### Trägerwerkzeug / Drill holder / Corpo punta

Bezeichnung Designation Articolo	Bohrtiefe Drill depth Profondità foratura	D	l	l <sub>2</sub>	l <sub>3</sub>	h	d <sub>A</sub>	MK	Gewinde Thread Filetato
HO3000-3505-137SPW32	3,5 x D – 5,5 x D	30,0 – 35,05	183	137	57,9	-	32	-	-
HO3000-3505-187SPW32	5 x D – 7,5 x D	30,0 – 35,05	233,8	187	57,9	-	32	-	-
HO3000-3505-289SPW32	8 x D – 11,5 x D	30,0 – 35,05	335,4	289	57,9	-	32	-	-

**HINWEIS:** Trägerwerkzeuge werden mit Klemmschrauben, 2 Ersatzschrauben und Schlüssel geliefert.  
**INFORMATION:** Holders will be supplied with clamping screws, 2 spare screws and key.  
**NOTA:** L'utensile é fornito completo di 1 vite, 2 viti di ricambio e 1 chiave.

## Serie / Series / Serie

**M**

Ø 24,41 mm – 35,05 mm  
14,5 x D – 28 x D

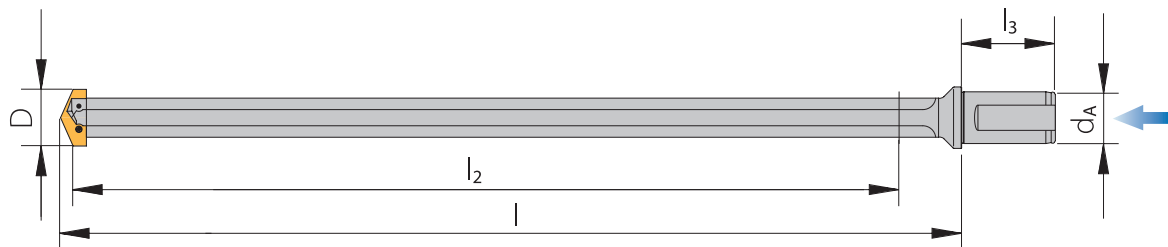
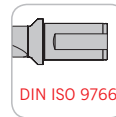

### Trägerwerkzeug / Drill holder / Corpo punta

Bezeichnung Designation Articolo	Bohrtiefe Drill depth Profondità foratura	D	l	l <sub>2</sub>	l <sub>3</sub>	h	d <sub>A</sub>	MK	Gewinde Thread Filetato
HM2441-3505-511GW32	14,5 x D – 20,5 x D	24,41 – 35,05	557,7	511	57,9	-	32	-	-
HM2441-3505-692GW32	19,5 x D – 28 x D	24,41 – 35,05	738,7	692	57,9	-	32	-	-

**HINWEIS:** Trägerwerkzeuge werden mit Klemmschrauben, 2 Ersatzschrauben und Schlüssel geliefert.  
**INFORMATION:** Holders will be supplied with clamping screws, 2 spare screws and key.  
**NOTA:** L'utensile é fornito completo di 1 vite, 2 viti di ricambio e 1 chiave.

Zubehör für Bohrer siehe Seite 94 – 95.  
Hinweis: Beachten Sie bitte die Anwendungshinweise zu diesen Haltern ab Seite 109!

Holder accessories see page 94 – 95.  
Remark: Please see the application guidelines for this holder on page 109!

Accessori corpo a pagina 94 – 95.  
Attenzione: Note di utilizzo per questo tipo di utensile a pagina 109!

# Schneidplatten-Bohrer mit DIN ISO 9766-Schaft

Flanged holders - DIN ISO 9766 shank  
Corpo punta - Attacco DIN ISO 9766

## Serie / Series / Serie

**Q**

Ø 34,37 mm – 47,8 mm  
1,5 x D – 3,5 x D

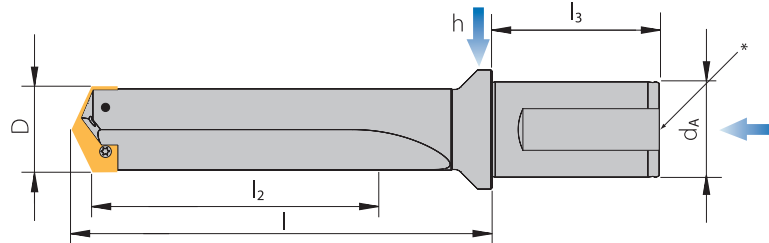
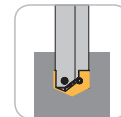
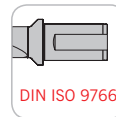

\* Gewinde G 1/4"  
Thread  
Filetato -W

### Trägerwerkzeug / Drill holder / Corpo punta

Bezeichnung Designation Articolo	Bohrtiefe Drill depth Profondità foratura	D	l	l <sub>2</sub>	l <sub>3</sub>	h	d <sub>A</sub>	MK	Gewinde Thread Filetato
HQ3437-4780-76GW40	1,5 x D – 2 x D	34,37 – 47,8	129,8	76	70,1	1/4"	40	-	-
HQ3437-4780-76GW40-W	1,5 x D – 2 x D	34,37 – 47,8	129,8	76	70,1	-	40	-	G 1/4"
HQ3437-4780-121GW40	2,5 x D – 3,5 x D	34,37 – 47,8	177,8	121	70,1	-	40	-	-
HQ3437-4780-121GW40-W	2,5 x D – 3,5 x D	34,37 – 47,8	177,8	121	70,1	-	40	-	G 1/4"

Verschlusschraube 20906-G1/8  
Grub screw 20906-G1/8  
Tappo filetato 20906-G1/8

**HINWEIS:** Trägerwerkzeuge werden mit Klemmschrauben, 2 Ersatzschrauben und Schlüssel geliefert.  
**INFORMATION:** Holders will be supplied with clamping screws, 2 spare screws and key.  
**NOTA:** L'utensile é fornito completo di 1 vite, 2 viti di ricambio e 1 chiave.

## Serie / Series / Serie

**Q**

Ø 34,37 mm – 47,8 mm  
3 x D – 6 x D

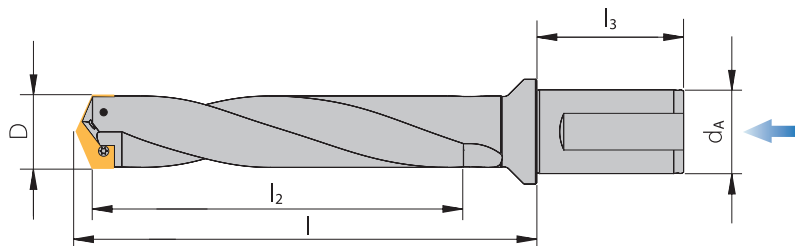
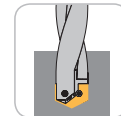
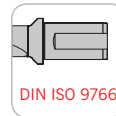

### Trägerwerkzeug / Drill holder / Corpo punta

Bezeichnung Designation Articolo	Bohrtiefe Drill depth Profondità foratura	D	l	l <sub>2</sub>	l <sub>3</sub>	h	d <sub>A</sub>	MK	Gewinde Thread Filetato
HQ3437-4780-165SPW40	3 x D – 4,5 x D	34,37 – 47,8	222,3	165	70,1	-	40	-	-
HQ3437-4780-165SPW40-W	3 x D – 4,5 x D	34,37 – 47,8	222,3	165	70,1	-	40	-	G 1/4"
HQ3437-4780-210SPW40	4 x D – 6 x D	34,37 – 47,8	266,7	210	70,1	-	40	-	-
HQ3437-4780-210SPW40-W	4 x D – 6 x D	34,37 – 47,8	266,7	210	70,1	-	40	-	G 1/4"

**HINWEIS:** Trägerwerkzeuge werden mit Klemmschrauben, 2 Ersatzschrauben und Schlüssel geliefert.  
**INFORMATION:** Holders will be supplied with clamping screws, 2 spare screws and key.  
**NOTA:** L'utensile é fornito completo di 1 vite, 2 viti di ricambio e 1 chiave.

# Schneidplatten-Bohrer mit DIN ISO 9766-Schaft

Flanged holders - DIN ISO 9766 shank  
Corpo punta - Attacco DIN ISO 9766

## Serie / Series / Serie

**Q**

Ø 34,37 mm – 47,8 mm  
7 x D – 22,5 x D

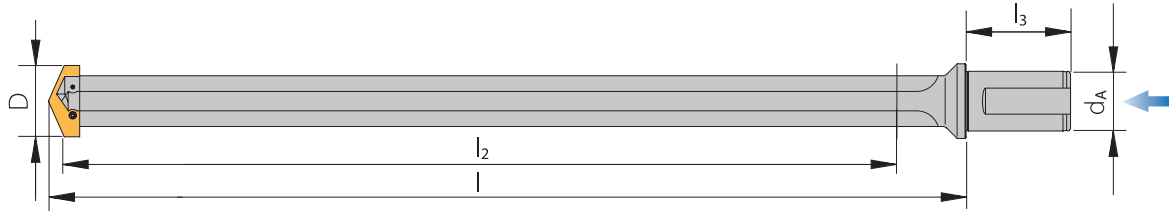
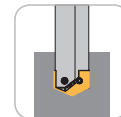
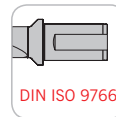

## Trägerwerkzeug / Drill holder / Corpo punta

Bezeichnung Designation Articolo	Bohrtiefe Drill depth Profondità foratura	D	l	l <sub>2</sub>	l <sub>3</sub>	h	d <sub>A</sub>	MK	Gewinde Thread Filetato
HQ3437-4780-349GW40	7 x D – 10 x D	34,37 – 47,8	406,4	349	70,1	-	40	-	-
HQ3437-4780-558GW40	11,5 x D – 16 x D	34,37 – 47,8	615,9	558	70,1	-	40	-	-
HQ3437-4780-787GW40	16 x D – 22,5 x D	34,37 – 47,8	844,5	787	70,1	-	40	-	-

**HINWEIS:** Trägerwerkzeuge werden mit Klemmschrauben, 2 Ersatzschrauben und Schlüssel geliefert.  
**INFORMATION:** Holders will be supplied with clamping screws, 2 spare screws and key.  
**NOTA:** L'utensile é fornito completo di 1 vite, 2 viti di ricambio e 1 chiave.

## Serie / Series / Serie

**S**

Ø 46,99 mm – 65,28 mm  
1,5 x D – 2,5 x D

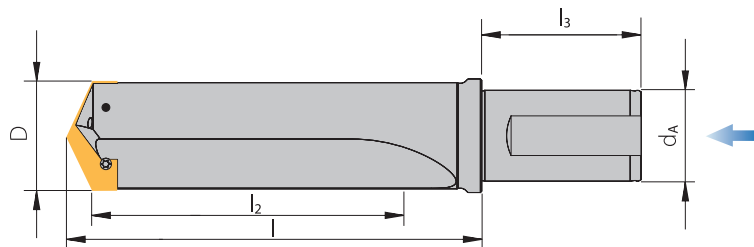

## Trägerwerkzeug / Drill holder / Corpo punta

Bezeichnung Designation Articolo	Bohrtiefe Drill depth Profondità foratura	D	l	l <sub>2</sub>	l <sub>3</sub>	h	d <sub>A</sub>	MK	Gewinde Thread Filetato
HS4699-6528-130GW40	1,5 x D – 2,5 x D	46,99 – 65,28	184,2	130	70,1	-	40	-	-
HS4699-6528-130GW40-W	1,5 x D – 2,5 x D	46,99 – 65,28	184,2	130	70,1	-	40	-	G 1/4"

**HINWEIS:** Trägerwerkzeuge werden mit Klemmschrauben, 2 Ersatzschrauben und Schlüssel geliefert.  
**INFORMATION:** Holders will be supplied with clamping screws, 2 spare screws and key.  
**NOTA:** L'utensile é fornito completo di 1 vite, 2 viti di ricambio e 1 chiave.

Zubehör für Bohrer siehe Seite 94 – 95.  
Hinweis: Beachten Sie bitte die Anwendungshinweise zu diesen Haltern ab Seite 109!

Holder accessories see page 94 – 95.  
Remark: Please see the application guidelines for this holder on page 109!

Accessori corpo a pagina 94 – 95.  
Attenzione: Note di utilizzo per questo tipo di utensile a pagina 109!

# Schneidplatten-Bohrer mit DIN ISO 9766-Schaft

Flanged holders - DIN ISO 9766 shank  
Corpo punta - Attacco DIN ISO 9766

## Serie / Series / Serie

**S**

Ø 46,99 mm – 65,28 mm  
3,5 x D – 4,5 x D

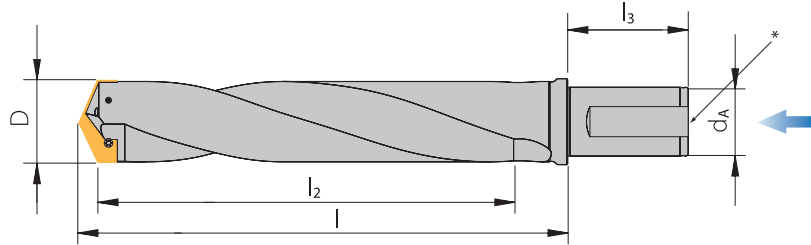
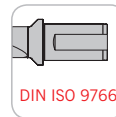

\* Gewinde G 1/4"  
Thread  
Filetato -W

### Trägerwerkzeug / Drill holder / Corpo punta

Bezeichnung Designation Articolo	Bohrtiefe Drill depth Profondità foratura	D	l	l <sub>2</sub>	l <sub>3</sub>	h	d <sub>A</sub>	MK	Gewinde Thread Filetato
HS4699-6528-232SPW40	3,5 x D – 4,5 x D	46,99 – 65,28	285,8	232	70,1	-	40	-	-
HS4699-6528-232SPW40-W	3,5 x D – 4,5 x D	46,99 – 65,28	285,8	232	70,1	-	40	-	G 1/4"

**HINWEIS:** Trägerwerkzeuge werden mit Klemmschrauben, 2 Ersatzschrauben und Schlüssel geliefert.

**INFORMATION:** Holders will be supplied with clamping screws, 2 spare screws and key.

**NOTA:** L'utensile é fornito completo di 1 vite, 2 viti di ricambio e 1 chiave.

## Serie / Series / Serie

**S**

Ø 46,99 mm – 65,28 mm  
6 x D – 18,5 x D

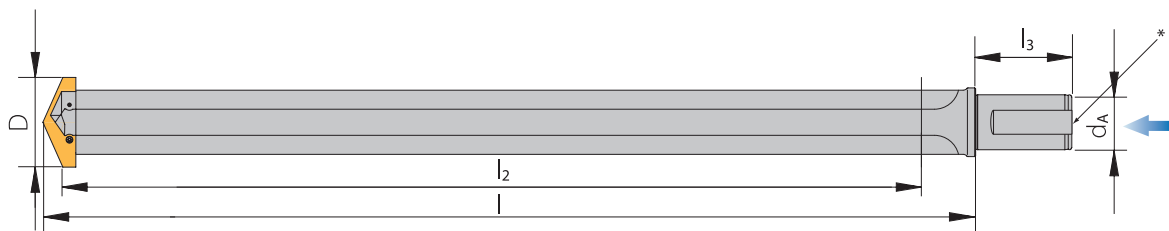
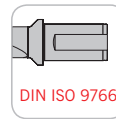

\* Gewinde G 1/4"  
Thread  
Filetato -W

### Trägerwerkzeug / Drill holder / Corpo punta

Bezeichnung Designation Articolo	Bohrtiefe Drill depth Profondità foratura	D	l	l <sub>2</sub>	l <sub>3</sub>	h	d <sub>A</sub>	MK	Gewinde Thread Filetato
HS4699-6528-422GW40	6 x D – 8,5 x D	46,99 – 65,28	476,3	422	70,1	-	40	-	-
HS4699-6528-422GW40-W	6 x D – 8,5 x D	46,99 – 65,28	476,3	422	70,1	-	40	-	G 1/4"
HS4699-6528-625GW40	9,5 x D – 13 x D	46,99 – 65,28	679,5	625	70,1	-	40	-	-
HS4699-6528-879GW40	13 x D – 18,5 x D	46,99 – 65,28	933,5	879	70,1	-	40	-	-

**HINWEIS:** Trägerwerkzeuge werden mit Klemmschrauben, 2 Ersatzschrauben und Schlüssel geliefert.

**INFORMATION:** Holders will be supplied with clamping screws, 2 spare screws and key.

**NOTA:** L'utensile é fornito completo di 1 vite, 2 viti di ricambio e 1 chiave.

Zubehör für Bohrer siehe Seite 94 – 95.

Hinweis: Beachten Sie bitte die Anwendungshinweise zu diesen Haltern ab Seite 109!

Holder accessories see page 94 – 95.

Remark: Please see the application guidelines for this holder on page 109!

Accessori corpo a pagina 94 – 95.

Attenzione: Note di utilizzo per questo tipo di utensile a pagina 109!

# Schneidplatten-Bohrer mit Morsekegel

Taper shank holders  
Corpo con Cono Morse

## Serie / Series / Serie

**A**  
Ø 9,5 mm – 11,07 mm  
2,5 x D – 3 x D

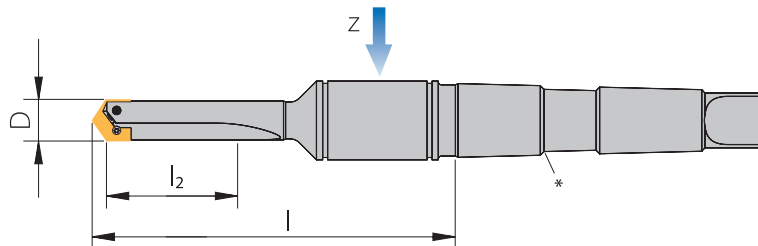
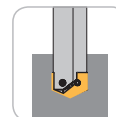

\* Morsekegel (MK) nach DIN ISO 296  
Taper shank (MK) to DIN ISO 296  
Cono Morse (MK) secondo DIN ISO 296

## Trägerwerkzeug / Drill holder / Corpo punta

Bezeichnung Designation Articolo	Bohrtiefe Drill depth Profondità foratura	D	l	l <sub>2</sub>	l <sub>3</sub>	d <sub>A</sub>	z	MK
HA950-1107-32GMK2	2,5 x D – 3 x D	9,5 – 11,07	88	32	-	-	2KDA	MK2

**HINWEIS:** Trägerwerkzeuge werden mit Klemmschrauben, 2 Ersatzschrauben und Schlüssel geliefert.  
**INFORMATION:** Holders will be supplied with clamping screws, 2 spare screws and key.  
**NOTA:** L'utensile é fornito completo di 1 vite, 2 viti di ricambio e 1 chiave.

## Serie / Series / Serie

**A**  
Ø 9,5 mm – 11,07 mm  
5 x D – 11,5 x D

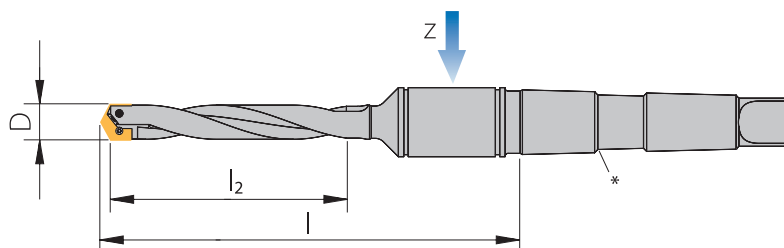
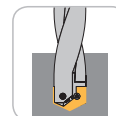

\* Morsekegel (MK) nach DIN ISO 296  
Taper shank (MK) to DIN ISO 296  
Cono Morse (MK) secondo DIN ISO 296

## Trägerwerkzeug / Drill holder / Corpo punta

Bezeichnung Designation Articolo	Bohrtiefe Drill depth Profondità foratura	D	l	l <sub>2</sub>	l <sub>3</sub>	d <sub>A</sub>	z	MK
HA950-1107-60SPMK2	5 x D – 6 x D	9,5 – 11,07	116,7	60	-	-	2KDA	MK2
HA950-1107-111SPMK2	10 x D – 11,5 x D	9,5 – 11,07	167,4	111	-	-	2KDA	MK2

**HINWEIS:** Trägerwerkzeuge werden mit Klemmschrauben, 2 Ersatzschrauben und Schlüssel geliefert.  
**INFORMATION:** Holders will be supplied with clamping screws, 2 spare screws and key.  
**NOTA:** L'utensile é fornito completo di 1 vite, 2 viti di ricambio e 1 chiave.

Zubehör für Bohrer siehe Seite 94 – 95.  
Hinweis: Beachten Sie bitte die Anwendungshinweise zu diesen Haltern ab Seite 109!

Holder accessories see page 94 – 95.  
Remark: Please see the application guidelines for this holder on page 109!

Accessori corpo a pagina 94 – 95.  
Attenzione: Note di utilizzo per questo tipo di utensile a pagina 109!



# Schneidplatten-Bohrer mit Morsekegel

Taper shank holders  
Corpo con Cono Morse

## Serie / Series / Serie

**A**  
Ø 9,5 mm – 11,07 mm  
10 x D – 11,5 x D

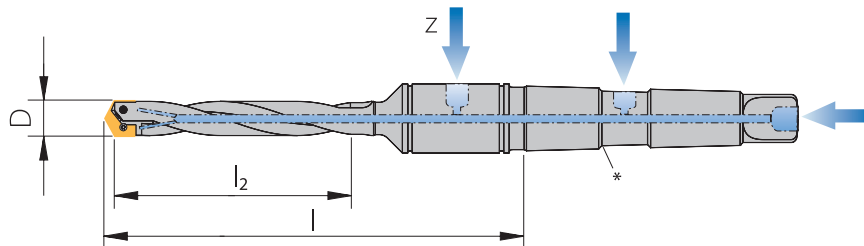

\* Morsekegel (MK) nach DIN ISO 296  
Taper shank (MK) to DIN ISO 296  
Cono Morse (MK) secondo DIN ISO 296

## Trägerwerkzeug / Drill holder / Corpo punta

Bezeichnung Designation Articolo	Bohrtiefe Drill depth Profondità foratura	D	l	l <sub>2</sub>	l <sub>3</sub>	d <sub>A</sub>	z	MK
HA950-1107-111SPMK2-G	10 x D – 11,5 x D	9,5 – 11,07	167,4	111	-	-	2KDA	MK2

**HINWEIS:** Trägerwerkzeuge werden mit Klemmschrauben, 2 Ersatzschrauben und Schlüssel geliefert.  
**INFORMATION:** Holders will be supplied with clamping screws, 2 spare screws and key.  
**NOTA:** L'utensile é fornito completo di 1 vite, 2 viti di ricambio e 1 chiave.

## Serie / Series / Serie

**C**  
Ø 11,1 mm – 12,95 mm  
2 x D – 2,5 x D

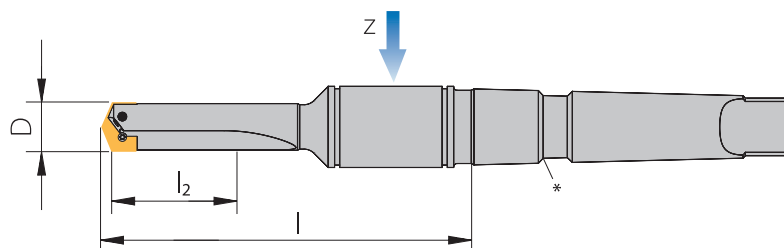

\* Morsekegel (MK) nach DIN ISO 296  
Taper shank (MK) to DIN ISO 296  
Cono Morse (MK) secondo DIN ISO 296

## Trägerwerkzeug / Drill holder / Corpo punta

Bezeichnung Designation Articolo	Bohrtiefe Drill depth Profondità foratura	D	l	l <sub>2</sub>	l <sub>3</sub>	d <sub>A</sub>	z	MK
HC1110-1295-32GMK2	2 x D – 2,5 x D	11,1 – 12,95	88	32	-	-	2KDA	MK2

**HINWEIS:** Trägerwerkzeuge werden mit Klemmschrauben, 2 Ersatzschrauben und Schlüssel geliefert.  
**INFORMATION:** Holders will be supplied with clamping screws, 2 spare screws and key.  
**NOTA:** L'utensile é fornito completo di 1 vite, 2 viti di ricambio e 1 chiave.

Zubehör für Bohrer siehe Seite 94 – 95.

Hinweis: Beachten Sie bitte die Anwendungshinweise zu diesen Haltern ab Seite 109!

Holder accessories see page 94 – 95.

Remark: Please see the application guidelines for this holder on page 109!

Accessori corpo a pagina 94 – 95.

Attenzione: Note di utilizzo per questo tipo di utensile a pagina 109!

Alle Angaben in mm / Dimensions in mm / Tutte le dimensioni in mm

# Schneidplatten-Bohrer mit Morsekegel

Taper shank holders  
Corpo con Cono Morse

## Serie / Series / Serie

C

Ø 11,1 mm – 12,95 mm  
4,5 x D – 10 x D

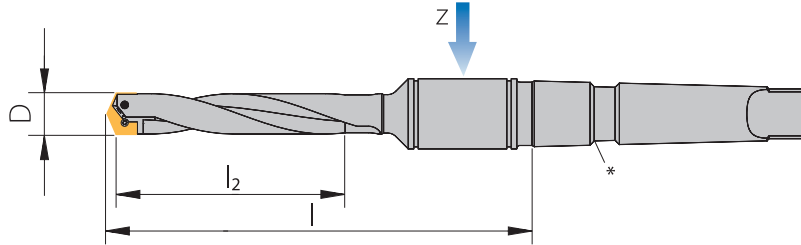

\* Morsekegel (MK) nach DIN ISO 296  
Taper shank (MK) to DIN ISO 296  
Cono Morse (MK) secondo DIN ISO 296

## Trägerwerkzeug / Drill holder / Corpo punta

Bezeichnung Designation Articolo	Bohrtiefe Drill depth Profondità foratura	D	l	l <sub>2</sub>	l <sub>3</sub>	d <sub>A</sub>	z	MK
HC1110-1295-60SPMK2	4,5 x D – 5 x D	11,1 – 12,95	116,7	60	-	-	2KDA	MK2
HC1110-1295-111SPMK2	8,5 x D – 10 x D	11,1 – 12,95	167,4	111	-	-	2KDA	MK2

**HINWEIS:** Trägerwerkzeuge werden mit Klemmschrauben, 2 Ersatzschrauben und Schlüssel geliefert.

**INFORMATION:** Holders will be supplied with clamping screws, 2 spare screws and key.

**NOTA:** L'utensile é fornito completo di 1 vite, 2 viti di ricambio e 1 chiave.

## Serie / Series / Serie

C

Ø 11,1 mm – 12,95 mm  
8,5 x D – 10 x D

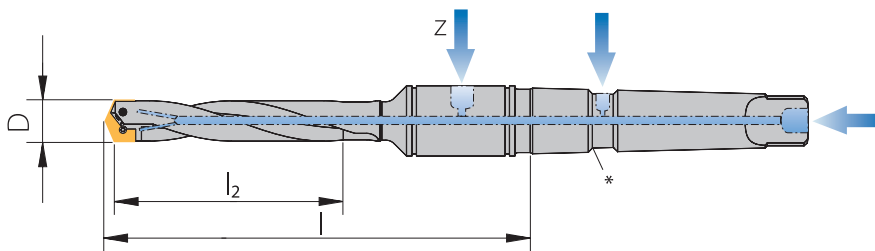

\* Morsekegel (MK) nach DIN ISO 296  
Taper shank (MK) to DIN ISO 296  
Cono Morse (MK) secondo DIN ISO 296

## Trägerwerkzeug / Drill holder / Corpo punta

Bezeichnung Designation Articolo	Bohrtiefe Drill depth Profondità foratura	D	l	l <sub>2</sub>	l <sub>3</sub>	d <sub>A</sub>	z	MK
HC1110-1295-111SPMK2-G	8,5 x D – 10 x D	11,1 – 12,95	167,4	111	-	-	2KDA	MK2

**HINWEIS:** Trägerwerkzeuge werden mit Klemmschrauben, 2 Ersatzschrauben und Schlüssel geliefert.

**INFORMATION:** Holders will be supplied with clamping screws, 2 spare screws and key.

**NOTA:** L'utensile é fornito completo di 1 vite, 2 viti di ricambio e 1 chiave.

Zubehör für Bohrer siehe Seite 94 – 95.

Hinweis: Beachten Sie bitte die Anwendungshinweise zu diesen Haltern ab Seite 109!

Holder accessories see page 94 – 95.

Remark: Please see the application guidelines for this holder on page 109!

Accessori corpo a pagina 94 – 95.

Attenzione: Note di utilizzo per questo tipo di utensile a pagina 109!

# Schneidplatten-Bohrer mit Morsekegel

Taper shank holders  
Corpo con Cono Morse

## Serie / Series / Serie

**E**

Ø 12,98 mm – 17,65 mm  
1,5 x D – 2,5 x D

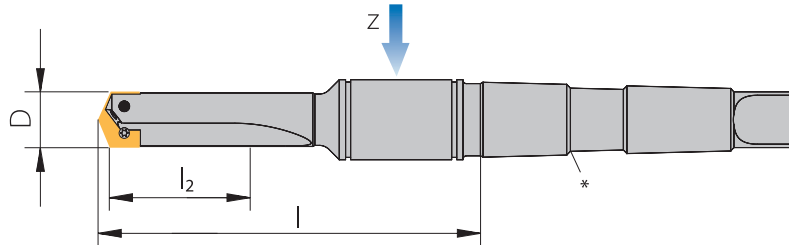
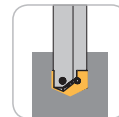

\* Morsekegel (MK) nach DIN ISO 296  
Taper shank (MK) to DIN ISO 296  
Cono Morse (MK) secondo DIN ISO 296

## Trägerwerkzeug / Drill holder / Corpo punta

Bezeichnung Designation Articolo	Bohrtiefe Drill depth Profondita foratura	D	l	l <sub>2</sub>	l <sub>3</sub>	d <sub>A</sub>	z	MK
HE1298-1765-35GMK2	1,5 x D – 2,5 x D	12,98 – 17,65	92,4	35	-	-	2KDA	MK2

**HINWEIS:** Trägerwerkzeuge werden mit Klemmschrauben, 2 Ersatzschrauben und Schlüssel geliefert.  
**INFORMATION:** Holders will be supplied with clamping screws, 2 spare screws and key.  
**NOTA:** L'utensile é fornito completo di 1 vite, 2 viti di ricambio e 1 chiave.

## Serie / Series / Serie

**G**

Ø 15,5 mm – 17,65 mm  
1,5 x D – 2 x D

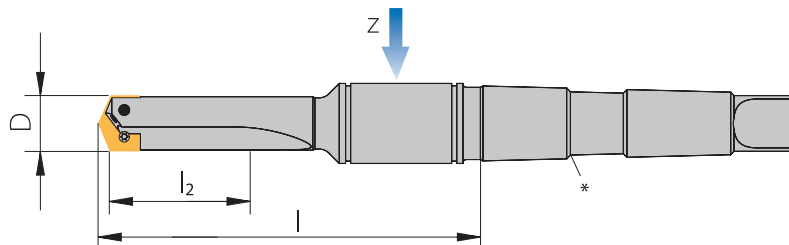

\* Morsekegel (MK) nach DIN ISO 296  
Taper shank (MK) to DIN ISO 296  
Cono Morse (MK) secondo DIN ISO 296

## Trägerwerkzeug / Drill holder / Corpo punta

Bezeichnung Designation Articolo	Bohrtiefe Drill depth Profondita foratura	D	l	l <sub>2</sub>	l <sub>3</sub>	d <sub>A</sub>	z	MK
HG1550-1765-35GMK2	1,5 x D – 2 x D	15,5 – 17,65	92,4	35	-	-	2KDA	MK2

**HINWEIS:** Trägerwerkzeuge werden mit Klemmschrauben, 2 Ersatzschrauben und Schlüssel geliefert.  
**INFORMATION:** Holders will be supplied with clamping screws, 2 spare screws and key.  
**NOTA:** L'utensile é fornito completo di 1 vite, 2 viti di ricambio e 1 chiave.

Zubehör für Bohrer siehe Seite 94 – 95.

**Hinweis:** Beachten Sie bitte die Anwendungshinweise zu diesen Haltern ab Seite 109!

Holder accessories see page 94 – 95.

Remark: Please see the application guidelines for this holder on page 109!

Accessori corpo a pagina 94 – 95.

Attenzione: Note di utilizzo per questo tipo di utensile a pagina 109!

# Schneidplatten-Bohrer mit Morsekegel

Taper shank holders  
Corpo con Cono Morse

## Serie / Series / Serie

**E**

Ø 12,98 mm – 17,65 mm  
3,5 x D – 13,5 x D

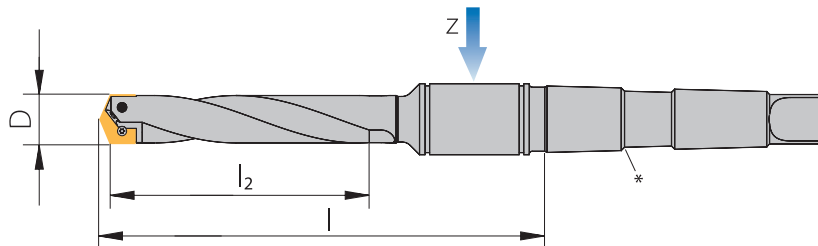

\* Morsekegel (MK) nach DIN ISO 296  
Taper shank (MK) to DIN ISO 296  
Cono Morse (MK) secondo DIN ISO 296

## Trägerwerkzeug / Drill holder / Corpo punta

Bezeichnung Designation Articolo	Bohrtiefe Drill depth Profondità foratura	D	l	l <sub>2</sub>	l <sub>3</sub>	d <sub>A</sub>	z	MK
HE1298-1765-64SPMK2	3,5 x D – 4,5 x D	12,98 – 17,65	121	64	-	-	2KDA	MK2
HE1298-1765-114SPMK2	6 x D – 8,5 x D	12,98 – 17,65	171,8	114	-	-	2KDA	MK2
HE1298-1765-178SPMK2	10 x D – 13,5 x D	12,98 – 17,65	235,8	178	-	-	2KDA	MK2

**HINWEIS:** Trägerwerkzeuge werden mit Klemmschrauben, 2 Ersatzschrauben und Schlüssel geliefert.  
*INFORMATION:* Holders will be supplied with clamping screws, 2 spare screws and key.  
*NOTA:* L'utensile é fornito completo di 1 vite, 2 viti di ricambio e 1 chiave.

## Serie / Series / Serie

**G**

Ø 15,5 mm – 17,65 mm  
3,5 x D – 11 x D

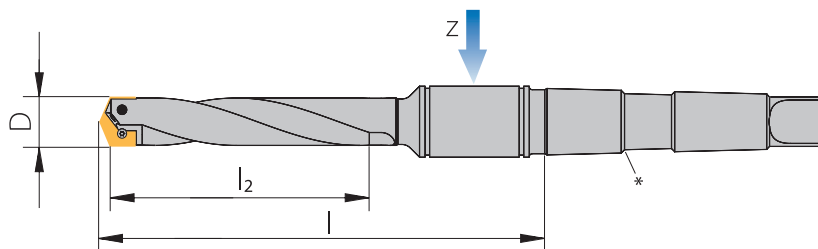

\* Morsekegel (MK) nach DIN ISO 296  
Taper shank (MK) to DIN ISO 296  
Cono Morse (MK) secondo DIN ISO 296

## Trägerwerkzeug / Drill holder / Corpo punta

Bezeichnung Designation Articolo	Bohrtiefe Drill depth Profondità foratura	D	l	l <sub>2</sub>	l <sub>3</sub>	d <sub>A</sub>	z	MK
HG1550-1765-64SPMK2	3,5 x D – 4 x D	15,5 – 17,65	121	64	-	-	2KDA	MK2
HG1550-1765-114SPMK2	6 x D – 7 x D	15,5 – 17,65	171,8	114	-	-	2KDA	MK2
HG1550-1765-178SPMK2	10 x D – 11 x D	15,5 – 17,65	235,8	178	-	-	2KDA	MK2

**HINWEIS:** Trägerwerkzeuge werden mit Klemmschrauben, 2 Ersatzschrauben und Schlüssel geliefert.  
*INFORMATION:* Holders will be supplied with clamping screws, 2 spare screws and key.  
*NOTA:* L'utensile é fornito completo di 1 vite, 2 viti di ricambio e 1 chiave.

**Zubehör für Bohrer siehe Seite 94 – 95.**  
**Hinweis:** Beachten Sie bitte die Anwendungshinweise zu diesen Haltern ab Seite 109!

Holder accessories see page 94 – 95.  
Remark: Please see the application guidelines for this holder on page 109!

Accessori corpo a pagina 94 – 95.  
Attenzione: Note di utilizzo per questo tipo di utensile a pagina 109!

# Schneidplatten-Bohrer mit Morsekegel

Taper shank holders  
Corpo con Cono Morse

## Serie / Series / Serie

**E**

Ø 12,98 mm – 17,65 mm  
6 x D – 8,5 x D

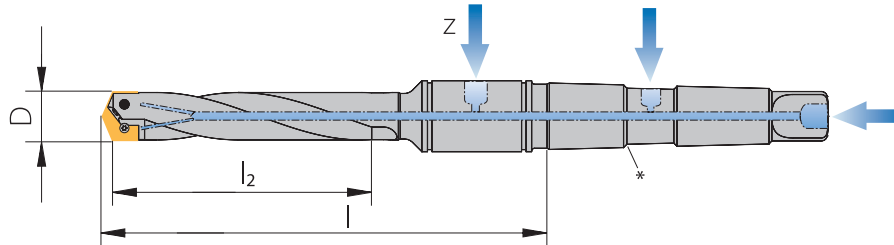

\* Morsekegel (MK) nach DIN ISO 296  
Taper shank (MK) to DIN ISO 296  
Cono Morse (MK) secondo DIN ISO 296

## Trägerwerkzeug / Drill holder / Corpo punta

Bezeichnung Designation Articolo	Bohrtiefe Drill depth Profondità foratura	D	l	l <sub>2</sub>	l <sub>3</sub>	d <sub>A</sub>	z	MK
HE1298-1765-114SPMK2-G	6 x D – 8,5 x D	12,98 – 17,65	171,8	114	-	-	2KDA	MK2

**HINWEIS:** Trägerwerkzeuge werden mit Klemmschrauben, 2 Ersatzschrauben und Schlüssel geliefert.  
**INFORMATION:** Holders will be supplied with clamping screws, 2 spare screws and key.  
**NOTA:** L'utensile é fornito completo di 1 vite, 2 viti di ricambio e 1 chiave.

## Serie / Series / Serie

**I**

Ø 17,53 mm – 24,38 mm  
2,5 x D – 3,5 x D

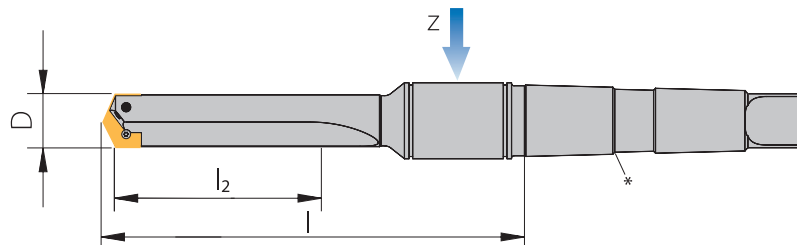

\* Morsekegel (MK) nach DIN ISO 296  
Taper shank (MK) to DIN ISO 296  
Cono Morse (MK) secondo DIN ISO 296

## Trägerwerkzeug / Drill holder / Corpo punta

Bezeichnung Designation Articolo	Bohrtiefe Drill depth Profondità foratura	D	l	l <sub>2</sub>	l <sub>3</sub>	d <sub>A</sub>	z	MK
HI1753-2438-70GMK3	2,5 x D – 3,5 x D	17,53 – 24,38	142,5	70	-	-	3KDA	MK3

**HINWEIS:** Trägerwerkzeuge werden mit Klemmschrauben, 2 Ersatzschrauben und Schlüssel geliefert.  
**INFORMATION:** Holders will be supplied with clamping screws, 2 spare screws and key.  
**NOTA:** L'utensile é fornito completo di 1 vite, 2 viti di ricambio e 1 chiave.

Zubehör für Bohrer siehe Seite 94 – 95.

Hinweis: Beachten Sie bitte die Anwendungshinweise zu diesen Haltern ab Seite 109!

Holder accessories see page 94 – 95.

Remark: Please see the application guidelines for this holder on page 109!

Accessori corpo a pagina 94 – 95.

Attenzione: Note di utilizzo per questo tipo di utensile a pagina 109!

# Schneidplatten-Bohrer mit Morsekegel

Taper shank holders  
Corpo con Cono Morse

## Serie / Series / Serie

**K**  
Ø 22,0 mm – 24,38 mm  
2,5 x D – 3 x D

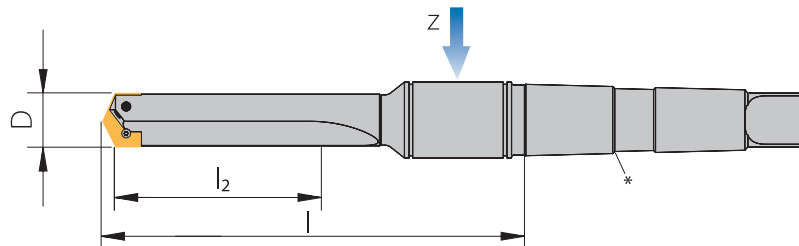

\* Morsekegel (MK) nach DIN ISO 296  
Taper shank (MK) to DIN ISO 296  
Cono Morse (MK) secondo DIN ISO 296

## Trägerwerkzeug / Drill holder / Corpo punta

Bezeichnung Designation Articolo	Bohrtiefe Drill depth Profondità foratura	D	l	l <sub>2</sub>	l <sub>3</sub>	d <sub>A</sub>	z	MK
HK2200-2438-70GMK3	2,5 x D – 3 x D	22,0 – 24,38	142,5	70	-	-	3KDA	MK3

**HINWEIS:** Trägerwerkzeuge werden mit Klemmschrauben, 2 Ersatzschrauben und Schlüssel geliefert.  
**INFORMATION:** Holders will be supplied with clamping screws, 2 spare screws and key.  
**NOTA:** L'utensile é fornito completo di 1 vite, 2 viti di ricambio e 1 chiave.

## Serie / Series / Serie

**I**  
Ø 17,53 mm – 24,38 mm  
4,5 x D – 15,5 x D

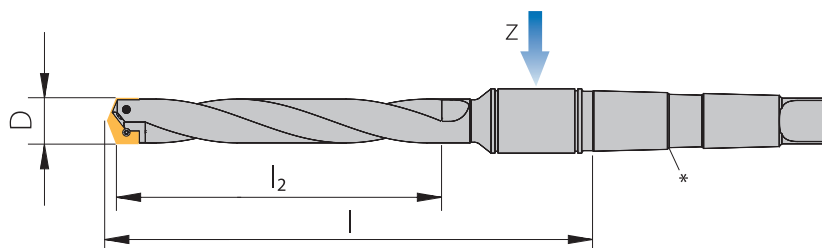

\* Morsekegel (MK) nach DIN ISO 296  
Taper shank (MK) to DIN ISO 296  
Cono Morse (MK) secondo DIN ISO 296

## Trägerwerkzeug / Drill holder / Corpo punta

Bezeichnung Designation Articolo	Bohrtiefe Drill depth Profondità foratura	D	l	l <sub>2</sub>	l <sub>3</sub>	d <sub>A</sub>	z	MK
HI1753-2438-121SPMK3	4,5 x D – 6,5 x D	17,53 – 24,38	193,9	121	-	-	3KDA	MK3
HI1753-2438-172SPMK3	7 x D – 9,5 x D	17,53 – 24,38	244,1	172	-	-	3KDA	MK3
HI1753-2438-273SPMK3	11 x D – 15,5 x D	17,53 – 24,38	345,7	273	-	-	3KDA	MK3

**HINWEIS:** Trägerwerkzeuge werden mit Klemmschrauben, 2 Ersatzschrauben und Schlüssel geliefert.  
**INFORMATION:** Holders will be supplied with clamping screws, 2 spare screws and key.  
**NOTA:** L'utensile é fornito completo di 1 vite, 2 viti di ricambio e 1 chiave.

Zubehör für Bohrer siehe Seite 94 – 95.  
Hinweis: Beachten Sie bitte die Anwendungshinweise zu diesen Haltern ab Seite 109!

Holder accessories see page 94 – 95.  
Remark: Please see the application guidelines for this holder on page 109!

Accessori corpo a pagina 94 – 95.  
Attenzione: Note di utilizzo per questo tipo di utensile a pagina 109!

# Schneidplatten-Bohrer mit Morsekegel

Taper shank holders  
Corpo con Cono Morse

## Serie / Series / Serie

**K**

Ø 22,0 mm – 24,38 mm  
4,5 x D – 12 x D

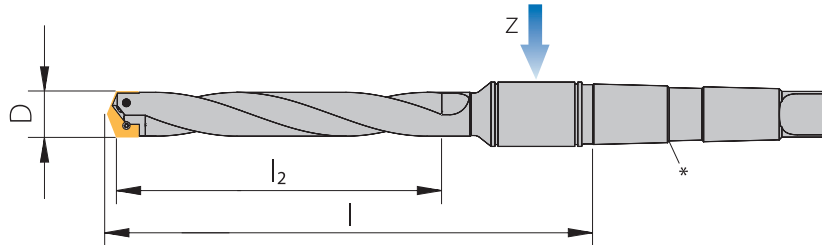

\* Morsekegel (MK) nach DIN ISO 296  
Taper shank (MK) to DIN ISO 296  
Cono Morse (MK) secondo DIN ISO 296

## Trägerwerkzeug / Drill holder / Corpo punta

Bezeichnung Designation Articolo	Bohrtiefe Drill depth Profondità foratura	D	l	l <sub>2</sub>	l <sub>3</sub>	d <sub>A</sub>	z	MK
HK2200-2438-121SPMK3	4,5 x D – 5,5 x D	22,0 – 24,38	193,9	121	-	-	3KDA	MK3
HK2200-2438-172SPMK3	7 x D – 7,5 x D	22,0 – 24,38	244,1	172	-	-	3KDA	MK3
HK2200-2438-273SPMK3	11 x D – 12 x D	22,0 – 24,38	345,7	273	-	-	3KDA	MK3

**HINWEIS:** Trägerwerkzeuge werden mit Klemmschrauben, 2 Ersatzschrauben und Schlüssel geliefert.  
**INFORMATION:** Holders will be supplied with clamping screws, 2 spare screws and key.  
**NOTA:** L'utensile é fornito completo di 1 vite, 2 viti di ricambio e 1 chiave.

## Serie / Series / Serie

**I**

Ø 17,53 mm – 24,38 mm  
2,5 x D – 9,5 x D

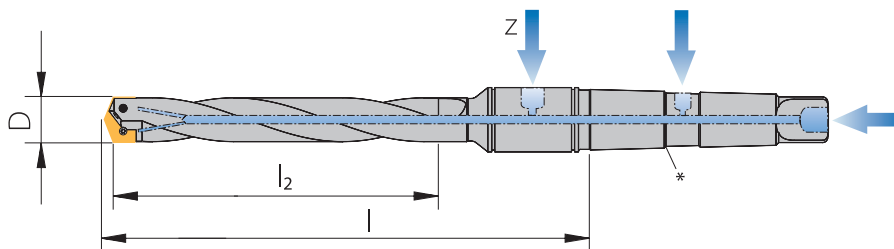

\* Morsekegel (MK) nach DIN ISO 296  
Taper shank (MK) to DIN ISO 296  
Cono Morse (MK) secondo DIN ISO 296

## Trägerwerkzeug / Drill holder / Corpo punta

Bezeichnung Designation Articolo	Bohrtiefe Drill depth Profondità foratura	D	l	l <sub>2</sub>	l <sub>3</sub>	d <sub>A</sub>	z	MK
HI1753-2438-70GMK3-G	2,5 x D – 3,5 x D	17,53 – 24,38	142,5	70	-	-	3KDA	MK3
HI1753-2438-121SPMK3-G	4,5 x D – 6,5 x D	17,53 – 24,38	193,9	121	-	-	3KDA	MK3
HI1753-2438-172SPMK3-G	7 x D – 9,5 x D	17,53 – 24,38	244,1	172	-	-	3KDA	MK3

**HINWEIS:** Trägerwerkzeuge werden mit Klemmschrauben, 2 Ersatzschrauben und Schlüssel geliefert.  
**INFORMATION:** Holders will be supplied with clamping screws, 2 spare screws and key.  
**NOTA:** L'utensile é fornito completo di 1 vite, 2 viti di ricambio e 1 chiave.

Zubehör für Bohrer siehe Seite 94 – 95.

Hinweis: Beachten Sie bitte die Anwendungshinweise zu diesen Haltern ab Seite 109!

Holder accessories see page 94 – 95.

Remark: Please see the application guidelines for this holder on page 109!

Accessori corpo a pagina 94 – 95.

Attenzione: Note di utilizzo per questo tipo di utensile a pagina 109!

# Schneidplatten-Bohrer mit Morsekegel

Taper shank holders  
Corpo con Cono Morse

## Serie / Series / Serie

### K

Ø 22,0 mm – 24,38 mm  
4,5 x D – 7,5 x D

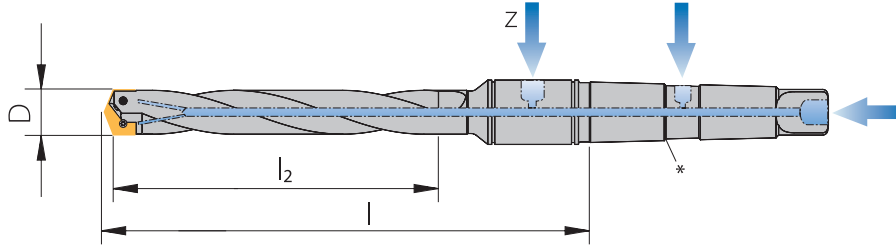

\* Morsekegel (MK) nach DIN ISO 296  
Taper shank (MK) to DIN ISO 297  
Cono Morse (MK) secondo DIN ISO 297

## Trägerwerkzeug / Drill holder / Corpo punta

Bezeichnung Designation Articolo	Bohrtiefe Drill depth Profondità foratura	D	l	l <sub>2</sub>	l <sub>3</sub>	d <sub>A</sub>	z	MK
HK2200-2438-121SPMK3-G	4,5 x D – 5,5 x D	22,0 – 24,38	193,9	121	-	-	3KDA	MK3
HK2200-2438-172SPMK3-G	7 x D – 7,5 x D	22,0 – 24,38	244,1	172	-	-	3KDA	MK3

**HINWEIS:** Trägerwerkzeuge werden mit Klemmschrauben, 2 Ersatzschrauben und Schlüssel geliefert.

**INFORMATION:** Holders will be supplied with clamping screws, 2 spare screws and key.

**NOTA:** L'utensile é fornito completo di 1 vite, 2 viti di ricambio e 1 chiave.

## Serie / Series / Serie

### M

Ø 24,41 mm – 35,05 mm  
2 x D – 3,5 x D

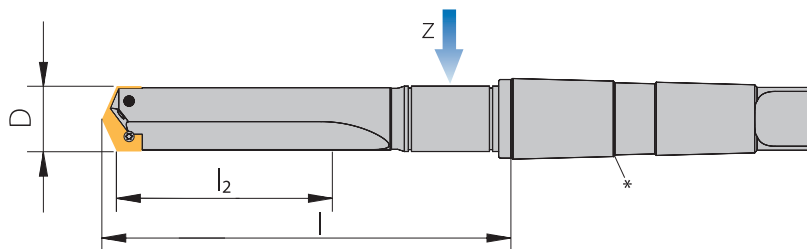

\* Morsekegel (MK) nach DIN ISO 296  
Taper shank (MK) to DIN ISO 296  
Cono Morse (MK) secondo DIN ISO 296

## Trägerwerkzeug / Drill holder / Corpo punta

Bezeichnung Designation Articolo	Bohrtiefe Drill depth Profondità foratura	D	l	l <sub>2</sub>	l <sub>3</sub>	d <sub>A</sub>	z	MK
HM2441-3505-86GMK4	2 x D – 3,5 x D	24,41 – 35,05	160,4	86	-	-	3KDA	MK4

**HINWEIS:** Trägerwerkzeuge werden mit Klemmschrauben, 2 Ersatzschrauben und Schlüssel geliefert.

**INFORMATION:** Holders will be supplied with clamping screws, 2 spare screws and key.

**NOTA:** L'utensile é fornito completo di 1 vite, 2 viti di ricambio e 1 chiave.

Zubehör für Bohrer siehe Seite 94 – 95.

Hinweis: Beachten Sie bitte die Anwendungshinweise zu diesen Haltern ab Seite 109!

Holder accessories see page 94 – 95.

Remark: Please see the application guidelines for this holder on page 109!

Accessori corpo a pagina 94 – 95.

Attenzione: Note di utilizzo per questo tipo di utensile a pagina 109!



# Schneidplatten-Bohrer mit Morsekegel

Taper shank holders  
Corpo con Cono Morse

## Serie / Series / Serie

**O**

Ø 30,0 mm – 35,05 mm  
2 x D – 3,5 x D

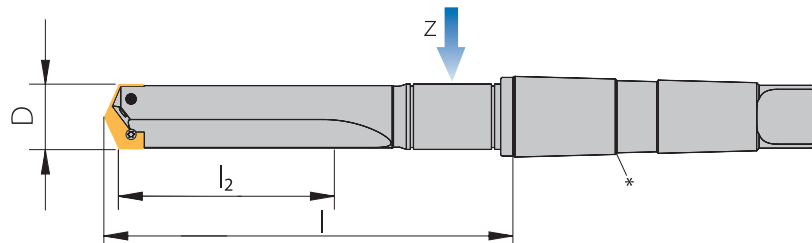
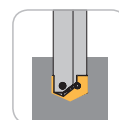

\* Morsekegel (MK) nach DIN ISO 296  
Taper shank (MK) to DIN ISO 296  
Cono Morse (MK) secondo DIN ISO 296

## Trägerwerkzeug / Drill holder / Corpo punta

Bezeichnung Designation Articolo	Bohrtiefe Drill depth Profondità foratura	D	l	l <sub>2</sub>	l <sub>3</sub>	d <sub>A</sub>	z	MK
HO3000-3505-86GMK4	2 x D – 3,5 x D	30,0 – 35,05	167,6	86	-	-	4KDA	MK4

**HINWEIS:** Trägerwerkzeuge werden mit Klemmschrauben, 2 Ersatzschrauben und Schlüssel geliefert.  
**INFORMATION:** Holders will be supplied with clamping screws, 2 spare screws and key.  
**NOTA:** L'utensile é fornito completo di 1 vite, 2 viti di ricambio e 1 chiave.

## Serie / Series / Serie

**M**

Ø 24,41 mm – 35,05 mm  
3,5 x D – 11,5 x D

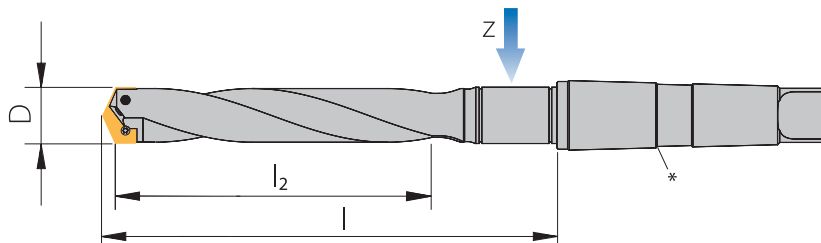

\* Morsekegel (MK) nach DIN ISO 296  
Taper shank (MK) to DIN ISO 296  
Cono Morse (MK) secondo DIN ISO 296

## Trägerwerkzeug / Drill holder / Corpo punta

Bezeichnung Designation Articolo	Bohrtiefe Drill depth Profondità foratura	D	l	l <sub>2</sub>	l <sub>3</sub>	d <sub>A</sub>	z	MK
HM2441-3505-137SPMK4	3,5 x D – 5,5 x D	24,41 – 35,05	211,2	137	-	-	3KDA	MK4
HM2441-3505-188SPMK4	5 x D – 7,5 x D	24,41 – 35,05	262	188	-	-	3KDA	MK4
HM2441-3505-289SPMK4	8 x D – 11,5 x D	24,41 – 35,05	363,6	289	-	-	3KDA	MK4

**HINWEIS:** Trägerwerkzeuge werden mit Klemmschrauben, 2 Ersatzschrauben und Schlüssel geliefert.  
**INFORMATION:** Holders will be supplied with clamping screws, 2 spare screws and key.  
**NOTA:** L'utensile é fornito completo di 1 vite, 2 viti di ricambio e 1 chiave.

Zubehör für Bohrer siehe Seite 94 – 95.

Hinweis: Beachten Sie bitte die Anwendungshinweise zu diesen Haltern ab Seite 109!

Holder accessories see page 94 – 95.

Remark: Please see the application guidelines for this holder on page 109!

Accessori corpo a pagina 94 – 95.

Attenzione: Note di utilizzo per questo tipo di utensile a pagina 109!

# Schneidplatten-Bohrer mit Morsekegel

Taper shank holders  
Corpo con Cono Morse

## Serie / Series / Serie

**O**

Ø 30,0 mm – 35,05 mm  
3,5 x D – 11,5 x D

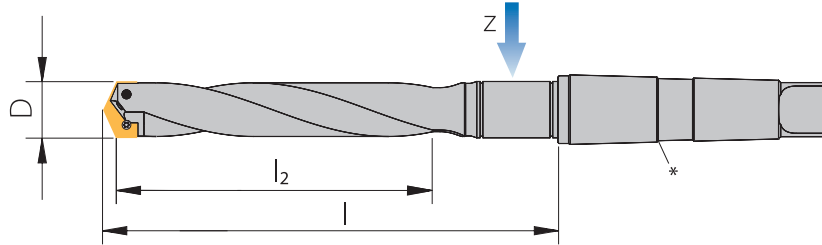

\* Morsekegel (MK) nach DIN ISO 296  
Taper shank (MK) to DIN ISO 296  
Cono Morse (MK) secondo DIN ISO 296

## Trägerwerkzeug / Drill holder / Corpo punta

Bezeichnung Designation Articolo	Bohrtiefe Drill depth Profondità foratura	D	l	l <sub>2</sub>	l <sub>3</sub>	d <sub>A</sub>	z	MK
HO3000-3505-137SPMK4	3,5 x D – 5,5 x D	30,0 – 35,05	218,4	137	-	-	4KDA	MK4
HO3000-3505-188SPMK4	5 x D – 7,5 x D	30,0 – 35,05	269,4	188	-	-	4KDA	MK4
HO3000-3505-289SPMK4	8 x D – 11,5 x D	30,0 – 35,05	370,8	289	-	-	4KDA	MK4

**HINWEIS:** Trägerwerkzeuge werden mit Klemmschrauben, 2 Ersatzschrauben und Schlüssel geliefert.  
**INFORMATION:** Holders will be supplied with clamping screws, 2 spare screws and key.  
**NOTA:** L'utensile é fornito completo di 1 vite, 2 viti di ricambio e 1 chiave.

## Serie / Series / Serie

**M**

Ø 24,41 mm – 35,05 mm  
2 x D – 7,5 x D

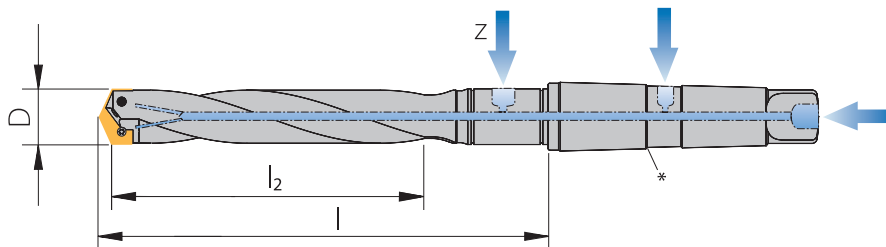

\* Morsekegel (MK) nach DIN ISO 296  
Taper shank (MK) to DIN ISO 296  
Cono Morse (MK) secondo DIN ISO 296

## Trägerwerkzeug / Drill holder / Corpo punta

Bezeichnung Designation Articolo	Bohrtiefe Drill depth Profondità foratura	D	l	l <sub>2</sub>	l <sub>3</sub>	d <sub>A</sub>	z	MK
HM2441-3505-86GMK4-G	2 x D – 3,5 x D	24,41 – 35,05	160,4	86	-	-	3KDA	MK4
HM2441-3505-137SPMK4-G	3,5 x D – 5,5 x D	24,41 – 35,05	211,2	137	-	-	3KDA	MK4
HM2441-3505-188SPMK4-G	5 x D – 7,5 x D	24,41 – 35,05	262	188	-	-	3KDA	MK4

**HINWEIS:** Trägerwerkzeuge werden mit Klemmschrauben, 2 Ersatzschrauben und Schlüssel geliefert.  
**INFORMATION:** Holders will be supplied with clamping screws, 2 spare screws and key.  
**NOTA:** L'utensile é fornito completo di 1 vite, 2 viti di ricambio e 1 chiave.

Zubehör für Bohrer siehe Seite 94 – 95.  
Hinweis: Beachten Sie bitte die Anwendungshinweise zu diesen Haltern ab Seite 109!

Holder accessories see page 94 – 95.  
Remark: Please see the application guidelines for this holder on page 109!

Accessori corpo a pagina 94 – 95.  
Attenzione: Note di utilizzo per questo tipo di utensile a pagina 109!

# Schneidplatten-Bohrer mit Morsekegel

Taper shank holders  
Corpo con Cono Morse

## Serie / Series / Serie

**Q**

Ø 34,37 mm – 47,8 mm  
2,5 x D – 3,5 x D

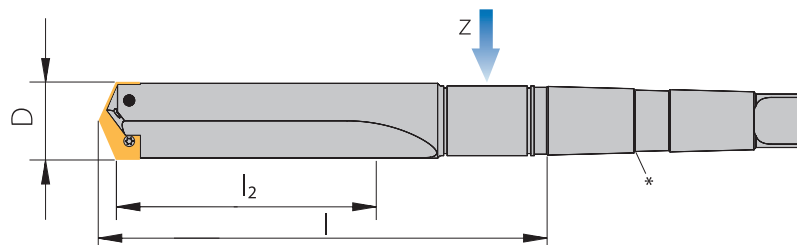
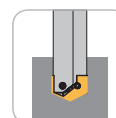

\* Morsekegel (MK) nach DIN ISO 296  
Taper shank (MK) to DIN ISO 296  
Cono Morse (MK) secondo DIN ISO 296

## Trägerwerkzeug / Drill holder / Corpo punta

Bezeichnung Designation Articolo	Bohrtiefe Drill depth Profondità foratura	D	l	l <sub>2</sub>	l <sub>3</sub>	d <sub>A</sub>	z	MK
HQ3437-4780-121GMK4	2,5 x D – 3,5 x D	34,37 – 47,8	206,4	121	-	-	4KDA	MK4

**HINWEIS:** Trägerwerkzeuge werden mit Klemmschrauben, 2 Ersatzschrauben und Schlüssel geliefert.  
**INFORMATION:** Holders will be supplied with clamping screws, 2 spare screws and key.  
**NOTA:** L'utensile é fornito completo di 1 vite, 2 viti di ricambio e 1 chiave.

## Serie / Series / Serie

**Q**

Ø 34,37 mm – 47,8 mm  
3 x D – 6 x D

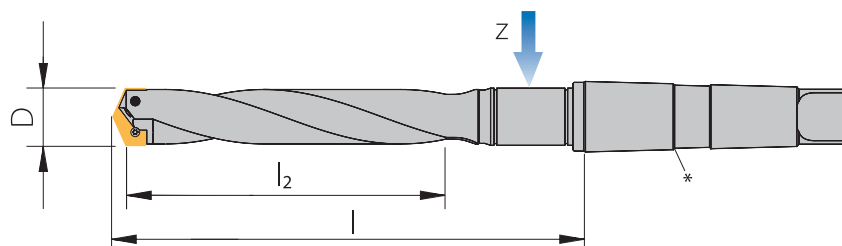
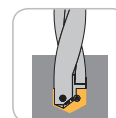

\* Morsekegel (MK) nach DIN ISO 296  
Taper shank (MK) to DIN ISO 296  
Cono Morse (MK) secondo DIN ISO 296

## Trägerwerkzeug / Drill holder / Corpo punta

Bezeichnung Designation Articolo	Bohrtiefe Drill depth Profondità foratura	D	l	l <sub>2</sub>	l <sub>3</sub>	d <sub>A</sub>	z	MK
HQ3437-4780-165SPMK4	3 x D – 4,5 x D	34,37 – 47,8	250,9	165	-	-	4KDA	MK4
HQ3437-4780-210SPMK4	4 x D – 6 x D	34,37 – 47,8	295,3	210	-	-	4KDA	MK4

**HINWEIS:** Trägerwerkzeuge werden mit Klemmschrauben, 2 Ersatzschrauben und Schlüssel geliefert.  
**INFORMATION:** Holders will be supplied with clamping screws, 2 spare screws and key.  
**NOTA:** L'utensile é fornito completo di 1 vite, 2 viti di ricambio e 1 chiave.

Zubehör für Bohrer siehe Seite 94 – 95.

Hinweis: Beachten Sie bitte die Anwendungshinweise zu diesen Haltern ab Seite 109!

Holder accessories see page 94 – 95.

Remark: Please see the application guidelines for this holder on page 109!

Accessori corpo a pagina 94 – 95.

Attenzione: Note di utilizzo per questo tipo di utensile a pagina 109!

Alle Angaben in mm / Dimensions in mm / Tutte le dimensioni in mm

# Schneidplatten-Bohrer mit Morsekegel

Taper shank holders  
Corpo con Cono Morse

## Serie / Series / Serie

**Q**

Ø 34,37 mm – 47,8 mm  
7 x D – 22,5 x D

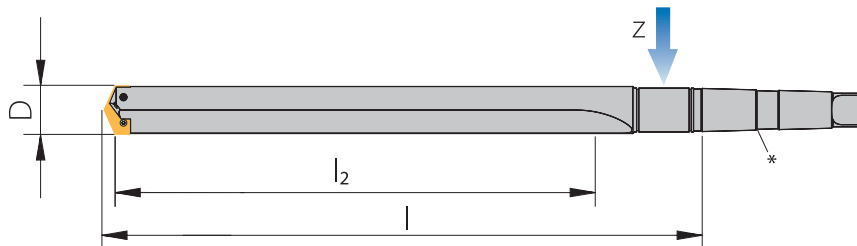
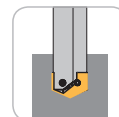

\* Morsekegel (MK) nach DIN ISO 296  
Taper shank (MK) to DIN ISO 296  
Cono Morse (MK) secondo DIN ISO 296

## Trägerwerkzeug / Drill holder / Corpo punta

Bezeichnung Designation Articolo	Bohrtiefe Drill depth Profondità foratura	D	l	l <sub>2</sub>	l <sub>3</sub>	d <sub>A</sub>	z	MK
HQ3437-4780-349GMK4	7 x D – 10 x D	34,37 – 47,8	435	349	-	-	4KDA	MK4
HQ3437-4780-558GMK4	11,5 x D – 16 x D	34,37 – 47,8	644,6	558	-	-	4KDA	MK4
HQ3437-4780-787GMK4	16 x D – 22,5 x D	34,37 – 47,8	873,2	787	-	-	4KDA	MK4

**HINWEIS:** Trägerwerkzeuge werden mit Klemmschrauben, 2 Ersatzschrauben und Schlüssel geliefert.  
**INFORMATION:** Holders will be supplied with clamping screws, 2 spare screws and key.  
**NOTA:** L'utensile é fornito completo di 1 vite, 2 viti di ricambio e 1 chiave.

## Serie / Series / Serie

**Q**

Ø 34,37 mm – 47,8 mm  
3 x D – 4,5 x D

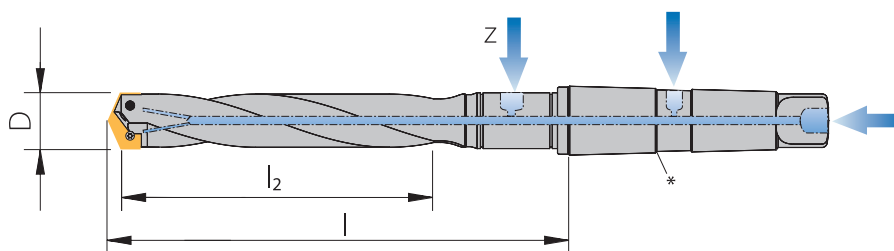

\* Morsekegel (MK) nach DIN ISO 296  
Taper shank (MK) to DIN ISO 296  
Cono Morse (MK) secondo DIN ISO 296

## Trägerwerkzeug / Drill holder / Corpo punta

Bezeichnung Designation Articolo	Bohrtiefe Drill depth Profondità foratura	D	l	l <sub>2</sub>	l <sub>3</sub>	d <sub>A</sub>	z	MK
HQ3437-4780-165SPMK4-G	3 x D – 4,5 x D	34,37 – 47,8	250,9	165	-	-	4KDA	MK4

**HINWEIS:** Trägerwerkzeuge werden mit Klemmschrauben, 2 Ersatzschrauben und Schlüssel geliefert.  
**INFORMATION:** Holders will be supplied with clamping screws, 2 spare screws and key.  
**NOTA:** L'utensile é fornito completo di 1 vite, 2 viti di ricambio e 1 chiave.

Zubehör für Bohrer siehe Seite 94 – 95.  
Hinweis: Beachten Sie bitte die Anwendungshinweise zu diesen Haltern ab Seite 109!

Holder accessories see page 94 – 95.  
Remark: Please see the application guidelines for this holder on page 109!

Accessori corpo a pagina 94 – 95.  
Attenzione: Note di utilizzo per questo tipo di utensile a pagina 109!

# Schneidplatten-Bohrer mit Morsekegel

Taper shank holders  
Corpo con Cono Morse

## Serie / Series / Serie

**S**

Ø 46,99 mm – 65,28 mm  
1,5 x D – 2,5 x D

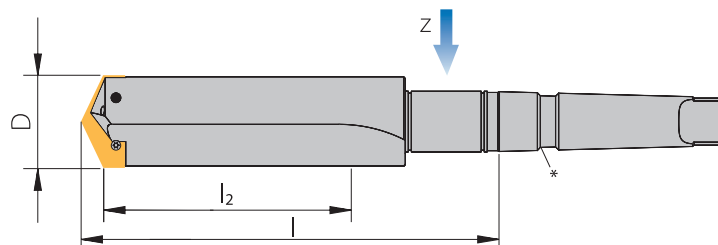
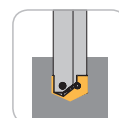

\* Morsekegel (MK) nach DIN ISO 296  
Taper shank (MK) to DIN ISO 296  
Cono Morse (MK) secondo DIN ISO 296

## Trägerwerkzeug / Drill holder / Corpo punta

Bezeichnung Designation Articolo	Bohrtiefe Drill depth Profondità foratura	D	l	l <sub>2</sub>	l <sub>3</sub>	d <sub>A</sub>	z	MK
HS4699-6528-130GMK5	1,5 x D – 2,5 x D	46,99 – 65,28	219,1	130	-	-	5KDA	MK5

**HINWEIS:** Trägerwerkzeuge werden mit Klemmschrauben, 2 Ersatzschrauben und Schlüssel geliefert.  
**INFORMATION:** Holders will be supplied with clamping screws, 2 spare screws and key.  
**NOTA:** L'utensile é fornito completo di 1 vite, 2 viti di ricambio e 1 chiave.

## Serie / Series / Serie

**S**

Ø 46,99 mm – 65,28 mm  
3,5 x D – 4,5 x D

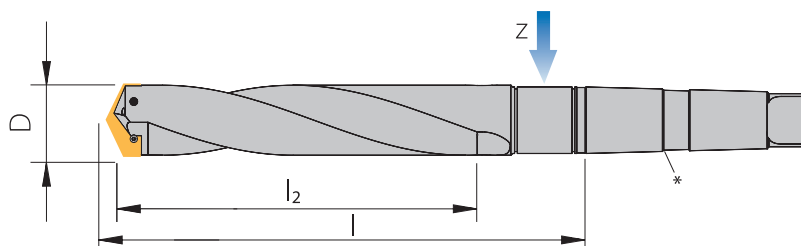
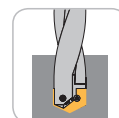

\* Morsekegel (MK) nach DIN ISO 296  
Taper shank (MK) to DIN ISO 296  
Cono Morse (MK) secondo DIN ISO 296

## Trägerwerkzeug / Drill holder / Corpo punta

Bezeichnung Designation Articolo	Bohrtiefe Drill depth Profondità foratura	D	l	l <sub>2</sub>	l <sub>3</sub>	d <sub>A</sub>	z	MK
HS4699-6528-232SPMK5	3,5 x D – 4,5 x D	46,99 – 65,28	320,7	232	-	-	5KDA	MK5

**HINWEIS:** Trägerwerkzeuge werden mit Klemmschrauben, 2 Ersatzschrauben und Schlüssel geliefert.  
**INFORMATION:** Holders will be supplied with clamping screws, 2 spare screws and key.  
**NOTA:** L'utensile é fornito completo di 1 vite, 2 viti di ricambio e 1 chiave.

Zubehör für Bohrer siehe Seite 94 – 95.

Hinweis: Beachten Sie bitte die Anwendungshinweise zu diesen Haltern ab Seite 109!

Holder accessories see page 94 – 95.

Remark: Please see the application guidelines for this holder on page 109!

Accessori corpo a pagina 94 – 95.

Attenzione: Note di utilizzo per questo tipo di utensile a pagina 109!

# Schneidplatten-Bohrer mit Morsekegel

Taper shank holders  
Corpo con Cono Morse

## Serie / Series / Serie

### S

Ø 46,99 mm – 65,28 mm  
6 x D – 18 x D

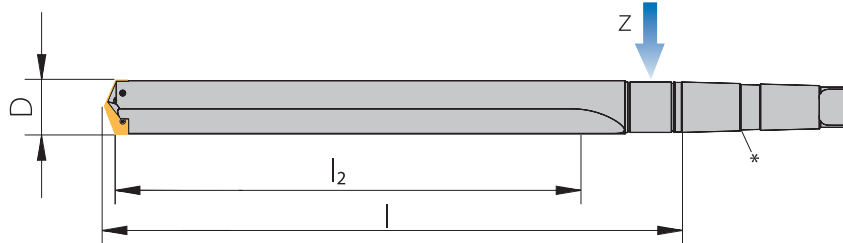

\* Morsekegel (MK) nach DIN ISO 296  
Taper shank (MK) to DIN ISO 296  
Cono Morse (MK) secondo DIN ISO 296

## Trägerwerkzeug / Drill holder / Corpo punta

Bezeichnung Designation Articolo	Bohrtiefe Drill depth Profondità foratura	D	l	l <sub>2</sub>	l <sub>3</sub>	d <sub>A</sub>	z	MK
HS4699-6528-422GMK5	6 x D – 8,5 x D	46,99 – 65,28	511,2	422	-	-	5KDA	MK5
HS4699-6528-625GMK5	9,5 x D – 13 x D	46,99 – 65,28	714,4	625	-	-	5KDA	MK5
HS4699-6528-879GMK5	13 x D – 18,5 x D	46,99 – 65,28	968,4	879	-	-	5KDA	MK5

**HINWEIS:** Trägerwerkzeuge werden mit Klemmschrauben, 2 Ersatzschrauben und Schlüssel geliefert.  
**INFORMATION:** Holders will be supplied with clamping screws, 2 spare screws and key.  
**NOTA:** L'utensile é fornito completo di 1 vite, 2 viti di ricambio e 1 chiave.

## Serie / Series / Serie

### U

Ø 62,38 mm – 89,08 mm  
1,5 x D – 2,5 x D

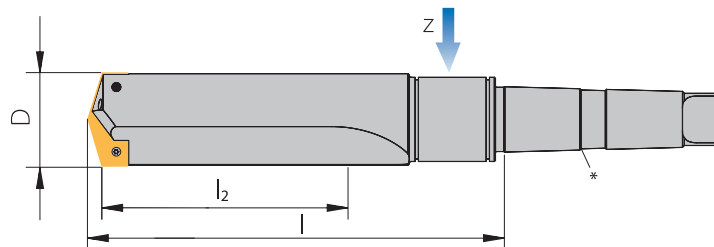

\* Morsekegel (MK) nach DIN ISO 296  
Taper shank (MK) to DIN ISO 296  
Cono Morse (MK) secondo DIN ISO 296

## Trägerwerkzeug / Drill holder / Corpo punta

Bezeichnung Designation Articolo	Bohrtiefe Drill depth Profondità foratura	D	l	l <sub>2</sub>	l <sub>3</sub>	d <sub>A</sub>	z	MK
HU6238-8908-172GMK5	1,5 x D – 2,5 x D	62,38 – 89,08	287,3	172	-	-	6KDA	MK5

**HINWEIS:** Trägerwerkzeuge werden mit Klemmschrauben, 2 Ersatzschrauben und Schlüssel geliefert.  
**INFORMATION:** Holders will be supplied with clamping screws, 2 spare screws and key.  
**NOTA:** L'utensile é fornito completo di 1 vite, 2 viti di ricambio e 1 chiave.

Zubehör für Bohrer siehe Seite 94 – 95.  
Hinweis: Beachten Sie bitte die Anwendungshinweise zu diesen Haltern ab Seite 109!

Holder accessories see page 94 – 95.  
Remark: Please see the application guidelines for this holder on page 109!

Accessori corpo a pagina 94 – 95.  
Attenzione: Note di utilizzo per questo tipo di utensile a pagina 109!

# Schneidplatten-Bohrer mit Morsekegel

Taper shank holders  
Corpo con Cono Morse

## Serie / Series / Serie

**U**

Ø 62,38 mm – 89,08 mm  
3 x D – 4 x D

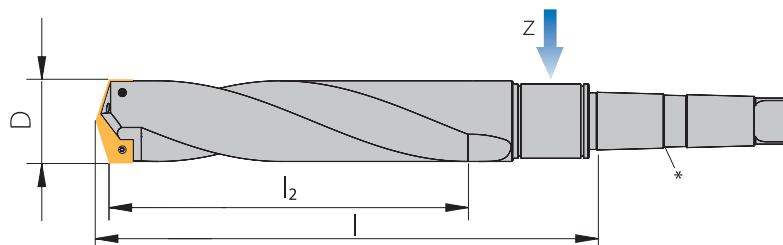

\* Morsekegel (MK) nach DIN ISO 296  
Taper shank (MK) to DIN ISO 296  
Cono Morse (MK) secondo DIN ISO 296

## Trägerwerkzeug / Drill holder / Corpo punta

Bezeichnung Designation Articolo	Bohrtiefe Drill depth Profondità foratura	D	l	l <sub>2</sub>	l <sub>3</sub>	d <sub>A</sub>	z	MK
HU6238-8908-273SPMK5	3 x D – 4 x D	62,38 – 89,08	388,9	273	-	-	6KDA	MK5

**HINWEIS:** Trägerwerkzeuge werden mit Klemmschrauben, 2 Ersatzschrauben und Schlüssel geliefert.  
**INFORMATION:** Holders will be supplied with clamping screws, 2 spare screws and key.  
**NOTA:** L'utensile é fornito completo di 1 vite, 2 viti di ricambio e 1 chiave.

## Serie / Series / Serie

**U**

Ø 62,38 mm – 89,08 mm  
5 x D – 14 x D

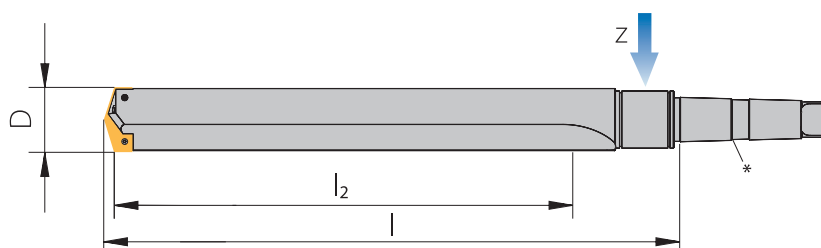

\* Morsekegel (MK) nach DIN ISO 296  
Taper shank (MK) to DIN ISO 296  
Cono Morse (MK) secondo DIN ISO 296

## Trägerwerkzeug / Drill holder / Corpo punta

Bezeichnung Designation Articolo	Bohrtiefe Drill depth Profondità foratura	D	l	l <sub>2</sub>	l <sub>3</sub>	d <sub>A</sub>	z	MK
HU6238-8908-464GMK5	5 x D – 7 x D	62,38 – 89,08	579,4	464	-	-	6KDA	MK5
HU6238-8908-660GMK5	7 x D – 10,5 x D	62,38 – 89,08	776,2	660	-	-	6KDA	MK5
HU6238-8908-889GMK5	9,5 x D – 14 x D	62,38 – 89,08	1004,8	889	-	-	6KDA	MK5

**HINWEIS:** Trägerwerkzeuge werden mit Klemmschrauben, 2 Ersatzschrauben und Schlüssel geliefert.  
**INFORMATION:** Holders will be supplied with clamping screws, 2 spare screws and key.  
**NOTA:** L'utensile é fornito completo di 1 vite, 2 viti di ricambio e 1 chiave.

Zubehör für Bohrer siehe Seite 94 – 95.

Hinweis: Beachten Sie bitte die Anwendungshinweise zu diesen Haltern ab Seite 109!

Holder accessories see page 94 – 95.

Remark: Please see the application guidelines for this holder on page 109!

Accessori corpo a pagina 94 – 95.

Attenzione: Note di utilizzo per questo tipo di utensile a pagina 109!

# Schneidplatten-Bohrer mit Morsekegel

Taper shank holders  
Corpo con Cono Morse

Serie / Series / Serie

**W**

Ø 87,76 mm – 114,48 mm  
1,5 x D – 2 x D

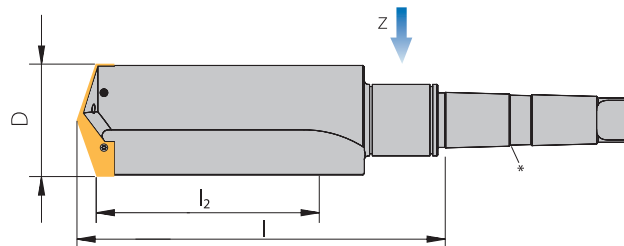

\* Morsekegel (MK) nach DIN ISO 296  
Taper shank (MK) to DIN ISO 296  
Cono Morse (MK) secondo DIN ISO 296

Trägerwerkzeug / Drill holder / Corpo punta

Bezeichnung Designation Articolo	Bohrtiefe Drill depth Profondità foratura	D	l	l <sub>2</sub>	l <sub>3</sub>	d <sub>A</sub>	z	MK
HW8776-11400-172GMK5	1,5 x D – 2 x D	87,76 – 114,48	296,8	172	-	-	6KDA	MK5

**HINWEIS:** Trägerwerkzeuge werden mit Klemmschrauben, 2 Ersatzschrauben und Schlüssel geliefert.  
**INFORMATION:** Holders will be supplied with clamping screws, 2 spare screws and key.  
**NOTA:** L'utensile é fornito completo di 1 vite, 2 viti di ricambio e 1 chiave.

Serie / Series / Serie

**W**

Ø 87,76 mm – 114,48 mm  
2 x D – 3 x D

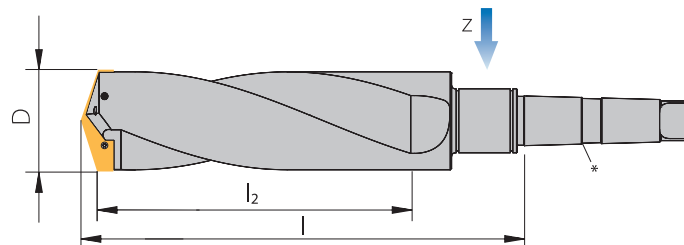

\* Morsekegel (MK) nach DIN ISO 296  
Taper shank (MK) to DIN ISO 296  
Cono Morse (MK) secondo DIN ISO 296

Trägerwerkzeug / Drill holder / Corpo punta

Bezeichnung Designation Articolo	Bohrtiefe Drill depth Profondità foratura	D	l	l <sub>2</sub>	l <sub>3</sub>	d <sub>A</sub>	z	MK
HW8776-11400-273SPMK5	2 x D – 3 x D	87,76 – 114,48	398,5	273	-	-	6KDA	MK5

**HINWEIS:** Trägerwerkzeuge werden mit Klemmschrauben, 2 Ersatzschrauben und Schlüssel geliefert.  
**INFORMATION:** Holders will be supplied with clamping screws, 2 spare screws and key.  
**NOTA:** L'utensile é fornito completo di 1 vite, 2 viti di ricambio e 1 chiave.

Zubehör für Bohrer siehe Seite 94 – 95.  
Hinweis: Beachten Sie bitte die Anwendungshinweise zu diesen Haltern ab Seite 109!

Holder accessories see page 94 – 95.  
Remark: Please see the application guidelines for this holder on page 109!

Accessori corpo a pagina 94 – 95.  
Attenzione: Note di utilizzo per questo tipo di utensile a pagina 109!



# Schneidplatten-Bohrer mit Morsekegel

Taper shank holders  
Corpo con Cono Morse

Serie / Series / Serie

**W**

Ø 87,76 mm – 114,48 mm  
4,5 x D – 10,5 x D

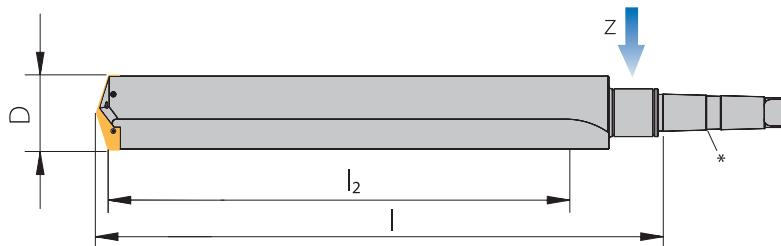
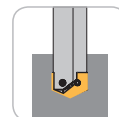

\* Morsekegel (MK) nach DIN ISO 296  
Taper shank (MK) to DIN ISO 296  
Cono Morse (MK) secondo DIN ISO 296

Trägerwerkzeug / Drill holder / Corpo punta

Bezeichnung Designation Articolo	Bohrtiefe Drill depth Profondità foratura	D	l	l <sub>2</sub>	l <sub>3</sub>	d <sub>A</sub>	z	MK
HW8776-11400-556GMK5	4,5 x D – 6 x D	87,76 – 114,48	681	556	-	-	6KDA	MK5
HW8776-11400-685GMK5	6 x D – 7,5 x D	87,76 – 114,48	811,2	685	-	-	6KDA	MK5
HW8776-11400-939GMK5	8 x D – 10,5 x D	87,76 – 114,48	1065,2	939	-	-	6KDA	MK5

**HINWEIS:** Trägerwerkzeuge werden mit Klemmschrauben, 2 Ersatzschrauben und Schlüssel geliefert.

**INFORMATION:** Holders will be supplied with clamping screws, 2 spare screws and key.

**NOTA:** L'utensile é fornito completo di 1 vite, 2 viti di ricambio e 1 chiave.

Zubehör für Bohrer siehe Seite 94 – 95.

Hinweis: Beachten Sie bitte die Anwendungshinweise zu diesen Haltern ab Seite 109!

Holder accessories see page 94 – 95.

Remark: Please see the application guidelines for this holder on page 109!

Accessori corpo a pagina 94 – 95.

Attenzione: Note di utilizzo per questo tipo di utensile a pagina 109!

Alle Angaben in mm / Dimensions in mm / Tutte le dimensioni in mm

### Serie/Series/Serie **A**

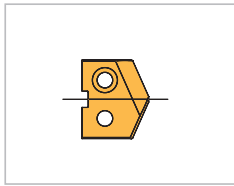

Seite  
Page  
Pagina **75 – 76**

Lieferbar in den Durchmessern von 9,5 mm bis 11 mm und den Sorten HSS5, HSS8, AK10, AK20 und AP40. Unbeschichtet und beschichtet (TiCN und TiAlN) erhältlich. Weitere Durchmesser, Sorten und Beschichtungen auf Anfrage.

Available in diameter 9.5 mm up to 11 mm. Grades HSS5, HSS8, AK10, AK20 and AP40. Uncoated and coated (TiCN and TiAlN). Other diameters, grades and coatings on request.

Disponibile da diametro 9,5 mm a diametro 11 mm. Gradi HSS5, HSS8, AK10, AK20 e AP40. Rivestiti e non rivestiti (TiCN e TiAlN). Diametri, gradi e rivestimenti diversi da quelli a catalogo disponibili su richiesta.

### Serie/Series/Serie **C**

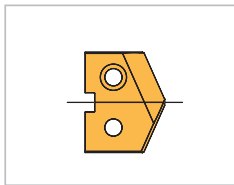

Seite  
Page  
Pagina **76 – 77**

Lieferbar in den Durchmessern von 11,5 mm bis 12,8 mm und den Sorten HSS5, HSS8, AK10, AK20 und AP40. Unbeschichtet und beschichtet (TiCN und TiAlN) erhältlich. Weitere Durchmesser, Sorten und Beschichtungen auf Anfrage.

Available in diameter 11.5 mm up to 12.8 mm. Grades HSS5, HSS8, AK10, AK20 and AP40. Uncoated and coated (TiCN and TiAlN). Other diameters, grades and coatings on request.

Disponibile da diametro 11,5 mm a diametro 12,8 mm. Gradi HSS5, HSS8, AK10, AK20 e AP40. Rivestiti e non rivestiti (TiCN e TiAlN). Diametri, gradi e rivestimenti diversi da quelli a catalogo disponibili su richiesta.

### Serie/Series/Serie **E+G**

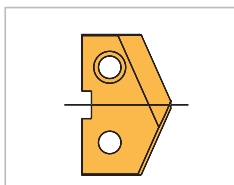

Seite  
Page  
Pagina **78 – 80**

Lieferbar in den Durchmessern von 13 mm bis 17,5 mm und den Sorten HSS5, HSS8, AK10, AK20 und AP40. Unbeschichtet und beschichtet (TiCN und TiAlN) erhältlich. Weitere Durchmesser, Sorten und Beschichtungen auf Anfrage.

Available in diameter 13 mm up to 17.5 mm. Grades HSS5, HSS8, AK10, AK20 and AP40. Uncoated and coated (TiCN and TiAlN). Other diameters, grades and coatings on request.

Disponibile da diametro 13 mm a diametro 17,5 mm. Gradi HSS5, HSS8, AK10, AK20 e AP40. Rivestiti e non rivestiti (TiCN e TiAlN). Diametri, gradi e rivestimenti diversi da quelli a catalogo disponibili su richiesta.

### Serie/Series/Serie **I+K**

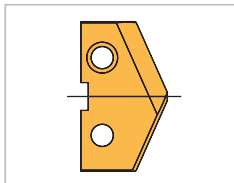

Seite  
Page  
Pagina **81 – 83**

Lieferbar in den Durchmessern von 17,8 mm bis 24 mm und den Sorten HSS, HSS5, HSS8, AK10, AK20 und AP40. Unbeschichtet und beschichtet (TiCN und TiAlN) erhältlich. Weitere Durchmesser, Sorten und Beschichtungen auf Anfrage.

Available in diameter 17.8 mm up to 24 mm. Grades HSS, HSS5, HSS8, AK10, AK20 and AP40. Uncoated and coated (TiCN and TiAlN). Other diameters, grades and coatings on request.

Disponibile da diametro 17,8 mm a diametro 24 mm. Gradi HSS, HSS5, HSS8, AK10, AK20 e AP40. Rivestiti e non rivestiti (TiCN e TiAlN). Diametri, gradi e rivestimenti diversi da quelli a catalogo disponibili su richiesta.

### Serie/Series/Serie **M+O**

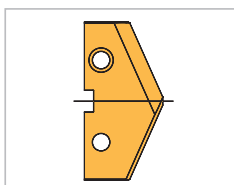

Seite  
Page  
Pagina **84 – 87**

Lieferbar in den Durchmessern von 24,5 mm bis 35 mm und den Sorten HSS, HSS5, HSS8, AK10, AK20 und AP40. Unbeschichtet und beschichtet (TiCN und TiAlN) erhältlich. Weitere Durchmesser, Sorten und Beschichtungen auf Anfrage.

Available in diameter 24.5 mm up to 35 mm. Grades HSS, HSS5, HSS8, AK10, AK20 and AP40. Uncoated and coated (TiCN and TiAlN). Other diameters, grades and coatings on request.

Disponibile da diametro 24,5 mm a diametro 35 mm. Gradi HSS, HSS5, HSS8, AK10, AK20 e AP40. Rivestiti e non rivestiti (TiCN e TiAlN). Diametri, gradi e rivestimenti diversi da quelli a catalogo disponibili su richiesta.

### Serie/Series/Serie **Q**

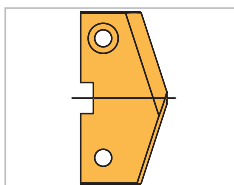

Seite  
Page  
Pagina **88 – 89**

Lieferbar in den Durchmessern von 36 mm bis 47 mm und den Sorten HSS, HSS5, AK20 und AP40. TiAlN beschichtet. Weitere Durchmesser, Sorten und Beschichtungen auf Anfrage.

Available in diameter 36 mm up to 47 mm. Grades HSS, HSS5, AK20 and AP40. TiAlN coated. Other diameters, grades and coatings on request.

Disponibile da diametro 36 mm a diametro 47 mm. Gradi HSS, HSS5, AK20 e AP40. Rivestiti TiAlN. Diametri, gradi e rivestimenti diversi da quelli a catalogo disponibili su richiesta.

## Serie/Series/Serie **S**

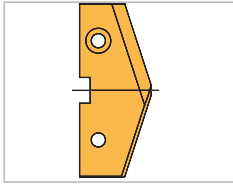

Seite  
Page  
Pagina **90 – 91**

**Lieferbar in den Durchmessern von 48 mm bis 65 mm und den Sorten HSS und HSS5. TiAIN beschichtet. Weitere Durchmesser, Sorten und Beschichtungen auf Anfrage.**

*Available in diameter 48 mm up to 65 mm. Grades HSS and HSS5. TiAIN coated. Other diameters, grades and coatings on request.*

Disponibile da diametro 48 mm a diametro 65 mm. Gradi HSS e HSS5. Rivestiti TiAIN. Diametri, gradi e rivestimenti diversi da quelli a catalogo disponibili su richiesta.

## Serie/Series/Serie **U**

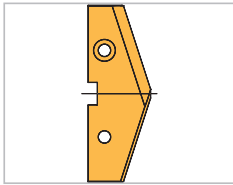

Seite  
Page  
Pagina **92**

**Lieferbar in den Durchmessern von 66 mm bis 89 mm und den Sorten HSS und HSS5. TiAIN beschichtet. Weitere Durchmesser, Sorten und Beschichtungen auf Anfrage.**

*Available in diameter 66 mm up to 89 mm. Grades HSS and HSS5. TiAIN coated. Other diameters, grades and coatings on request.*

Disponibile da diametro 66 mm a diametro 89 mm. Gradi HSS e HSS5. Rivestiti TiAIN. Diametri, gradi e rivestimenti diversi da quelli a catalogo disponibili su richiesta.

## Serie/Series/Serie **W**

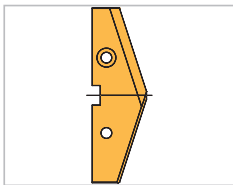

Seite  
Page  
Pagina **93**

**Lieferbar in den Durchmessern von 90 mm bis 114 mm und den Sorten HSS und HSS5. TiAIN beschichtet. Weitere Durchmesser, Sorten und Beschichtungen auf Anfrage.**

*Available in diameter 90 mm up to 114 mm. Grades HSS and HSS5. TiAIN coated. Other diameters, grades and coatings on request.*

Disponibile da diametro 90 mm a diametro 114 mm. Gradi HSS e HSS5. Rivestiti TiAIN. Diametri, gradi e rivestimenti diversi da quelli a catalogo disponibili su richiesta.

1

Universelle Geometrie für die Bearbeitung aller gängigen Werkstoffe. Mit Eckenschutz-fase für hohe Standzeiten. Dank der ausge-spitzen Schneide sind die Schneideinsätze selbstzentrierend und haben eine geringe Tendenz zum Verlaufen.

Lieferbarer Durchmesserbereich von **9,5 mm bis 114 mm**  
Bestellbeispiel: **PE14 HSS5/TiAIN**

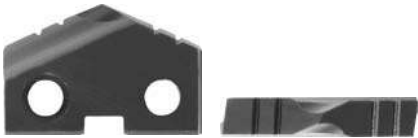

*Universal geometry for drilling most common materials. With corner chamfer for better tool life. The drill point geometry makes the insert self-centering providing good hole straightness.*

*Available in diameter range 9.5 mm to 114 mm  
Ordering example: PE14 HSS5/TiAIN*

Geometria da applicazione universale. Prima scelta per lavorabilità di qualsiasi materiale non trattato termicamente e a qualsiasi profondità di foratura. Bordo rinforzato per una maggiore durata e tagliente affilato per un migliore controllo truciolo.

Disponibile con gamma diametri da **9,5 mm a 114 mm**  
Esempio d'ordine: **PE14 HSS5/TiAIN**

### -AS

Unsere Geometrie „-AS“ mit speziell entwickelter Ausspitzung steht Ihnen in beschichteter (HSS5 und AK20 TiAIN) Variante zur Auswahl.

Nutzen Sie die Vorteile:

- reduzierte Vorschubkraft
- besseres Anbohrverhalten
- geringeres Verlaufen
- erste Wahl für tiefe Bohrungen
- reduziert Ausbrüche bei Durchgangsbohrungen

Lieferbarer Durchmesserbereich von **9,5 mm bis 35 mm**  
Bestellbeispiel: **PE14-AS HSS5/TiAIN**

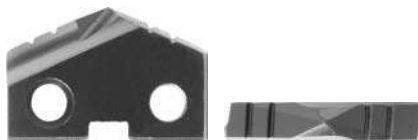

### -AS

*The „-AS“ geometry with especially developed edge is available in coated (HSS5 and AK20 TiAIN).*

*Advantages:*

- *lighter cutting action*
- *better pre-drilling ability*
- *improved straightness*
- *first choice for deep holes*
- *reduces outbreaks in throughholes*

*Available in diameter range 9.5 mm to 35 mm  
Ordering example: PE14-AS HSS5/TiAIN*

### -AS

La geometria „-AS“ con tagliente appositamente sviluppato è disponibile rivestita (HSS5 o nuda AK20 TiAIN).

Vantaggi:

- ridotte forze di taglio
- ottimo centraggio nei pre-fori
- migliore rettilineità del foro
- prima scelta per fori profondi
- ridotta rottura in uscita dai fori passanti

Disponibile con gamma diametri da **9,5 mm a 35 mm**  
Esempio d'ordine: **PE14-AS HSS5/TiAIN**

### -F Flachbohrmesser

Erweitern Sie mit den Flachbohrmessern „-F“ die Einsatzmöglichkeiten des SHARK-Drill®. Diese schnittige Geometrie mit Spanbrechern, sowie Eckenschutzfasen, lässt Sie (nur durch den Tausch der Bohrplatte) mit dem SHARK-Drill® nun auch Bohrungsgrundbearbeitungen oder Schraubensenkungen fertigen.

Lieferbarer Durchmesserbereich von **9,5 mm bis 47 mm**  
Bestellbeispiel: **PE14-F HSS5/TiAIN**



### -F for flat bottom

*Increase the usage of the SHARK-Drill® with the flat bottom inserts. With only the change of an insert the SHARK-Drill® now also drills flat-bottom holes as well as screw counterbores.*

*Available in diameter range 9.5 mm to 47 mm  
Ordering example: PE14-F HSS5/TiAIN*

### -F a fondo piano

Ampliate l'uso delle punte SHARK-Drill® con gli inserti con fondo piano. Con un semplice cambio di un inserto le punte SHARK-Drill® realizzeranno fori a fondo piatto, oltre a barenature o lamature.

Disponibile con gamma diametri da **9,5 mm a 47 mm**  
Esempio d'ordine: **PE14-F HSS5/TiAIN**

**Beschichtet / Coated / Rivestito****AK10 TiAlN**

PVD-Mehrlagenbeschichtung, Substrat K10 + TiAlN  
Ausgestattet mit einer speziellen Geometrie zur Bearbeitung von Grauguss (GG). Vergrößerte Eckenfasen und der verstärkte Schneidkeil, in Verbindung mit der TiAlN-Beschichtung, erzielen höchste Standzeiten in diesen Materialien. Im Bohrbereich nur unter stabilen Schnittbedingungen einzusetzen.

*PVD-multilayer coating, substrate K10 + TiAlN  
Designed with a special geometry for drilling grey and white cast iron. Extended corner clips and stronger main cutting edge combined with the TiAlN coating offers maximum tool life in these materials. Use in strong and stabile cutting environment.*

Rivestimento PVD-multistrato, substrato K10 + TiAlN  
Inserito costruito appositamente per la foratura di ghise grigie e acciainose a truciolo corto. Profilo tagliente irrobustito e smusso maggiorato abbinato ad un idoneo rivestimento TiAlN per una ottimizzata applicazione su questi materiali. Da utilizzare in condizioni di massima stabilità e rigidità.

**AK20 TiAlN**

PVD-Mehrlagenbeschichtung, Substrat K20 + TiAlN  
K20 Hartmetall mit höherer Zähigkeit als AK10. Zur Bearbeitung sämtlicher Gusswerkstoffe, NE-Metalle, Titan- und Titanlegierungen. Ebenfalls einsetzbar im Stahlbereich bis ca. 5 – 7xD unter stabilen Schnittbedingungen.

*PVD-multilayer coating, substrate K20 + TiAlN  
K20 Carbide Grade with higher toughness as AK10 for machining all cast iron materials, nonferrous metals, Titanium and Titanium Alloys. Up to 3xD under best conditions also in steel possible. Only for usage in a stable cutting environment up to 5/7xD.*

Rivestimento PVD-multistrato, substrato K20 + TiAlN  
Grado di metallo duro K20 con maggiore tenacità di AK10 idoneo alla lavorazione di materiale da fusione, materiali non ferrosi, Titanio leghe di Titanio. Per foratura di acciaio, in ottimali condizioni di lavoro può essere utilizzato anche fino a 3xD. Per materiali più essere impiegato anche fino a 5/7xD in ottime condizioni di lavoro.

**AP40 TiAlN**

PVD-Mehrlagenbeschichtung, Substrat P40 + TiAlN  
P40 Hartmetall. Zur Bearbeitung von Stählen und, mit Einschränkungen, auch von rostfreien Stählen. Für eine HM-Sorte verhältnismäßig zäh. Einsatz bis ca. 5 – 7xD unter stabilen Schnittbedingungen.

*PVD-multilayer coating, substrate P40 + TiAlN  
P40 Carbide grade for machining steel and with restriction also stainless steel. It is our toughest carbide grade. Only for usage in a stable cutting-environment up to 5/7xD.*

Rivestimento PVD-multistrato, substrato P40 + TiAlN  
Metallo duro grado P40 per lavorare acciaio e limitatamente anche acciai inox. Questo è il nostro grado di metallo duro più tenace. Solo per utilizzo in stabili condizioni di lavorazione fino a 5/7xD.

**HSS TiN**

PVD-Mehrlagenbeschichtung, HSS + TiN  
HSS ohne Co-Gehalt. Unsere zähste Sorte. Sehr gute Verschleißerkennung durch die TiN Beschichtung. Geeignet für die Bearbeitung von Nichteisenmetallen. Auch unter ungünstigen Bearbeitungsbedingungen.

*PVD-multilayer coating, HSS + TiN  
HSS without Co content, our toughest Grade. TiN coating make it easier to recognise wear. The best grade for poor machining conditions. The best grade for poor basic conditions.*

Rivestimento PVD-multistrato, HSS + TiN  
HSS senza contenuto di Co. è il grado HSS più tenace. Il rivestimento TiN permette di monitorare l'usura del tagliente. Il grado migliore per condizioni di lavoro sfavorevoli o per un utilizzo generico.

**HSS TiAlN**

PVD-Mehrlagenbeschichtung, HSS + TiAlN  
HSS ohne Co-Gehalt. Unsere zähste Sorte. Erhöhte Verschleißfestigkeit und Temperaturbeständigkeit durch die PVD-Mehrlagenbeschichtung. Geeignet für die Bearbeitung von Stahl und rostfreiem Stahl. Auch unter ungünstigen Bedingungen.

*PVD-multilayer coating, HSS + TiAlN  
HSS without Co content, our toughest Grade. Due to PVD multilayer coating improved wear and temperature resistance. The best grade for poor basic conditions.*

Rivestimento PVD-multistrato, HSS + TiAlN  
HSS senza contenuto di Co è il grado HSS più tenace. Il rivestimento multistrato PVD ne aumenta la vita tagliente grazie alla resistenza all'usura ed alle alte temperature. Il grado migliore per condizioni di lavoro sfavorevoli.

**Beschichtet / Coated / Rivestito****HSS5 TiAlN**

PVD-Mehrlagenbeschichtung, HSS5 + TiAlN  
**HSS mit 5% Co-Gehalt. Zähigkeit und Verschleißfestigkeit in einem ausgewogenen Verhältnis. Lieferbar im Durchmesserbereich 9,5 mm–114 mm.**

*PVD-multilayer coating, HSS5 + TiAlN  
 HSS with 5% cobalt contents, stock item from 9.5 mm–114 mm. Often the most universal grade. Excellent combination of toughness and wear resistance.*

Rivestimento PVD-multistrato, HSS + TiAlN  
 HSS con 5% di contenuto di Co. A magazzino articoli disponibili da Ø 9,5 mm a Ø 114 mm. E' il grado più universale. Tenacità e resistenza all' usura in giusta combinazione.

**HSS8 TiAlN**

PVD-Mehrlagenbeschichtung, HSS8 + TiAlN  
**HSS mit 8% Co-Gehalt. Durch die sehr hohe Verschleißfestigkeit erzielt diese Sorte bei stabilen Bedingungen die besten Standzeitergebnisse unter den HSS-Sorten. Lieferbar im Durchmesserbereich 9,5 mm–35 mm.**

*PVD-multilayer coating, HSS8 + TiAlN  
 HSS with 8% cobalt content. Because of the high wear resistance, this grade offers the best tool life of all the HSS grades especially under stable machining conditions. Stock item from 9.5 mm–35 mm.*

Rivestimento PVD-multistrato, HSS8 + TiAlN  
 HSS con 8% di contenuto di Cobalto. Grazie alla elevata resistenza all'usura, questa qualità offre la migliore vita in-serto die tutti i gradi HSS dove le condizioni di lavoro sono ottimali. A magazzino articoli disponibili da Ø 9,5 mm a Ø 35 mm.

**HSS8 TiCN**

PVD-Mehrlagenbeschichtung, HSS8 + TiCN  
**HSS mit 8% Co-Gehalt. Sehr hohe Verschleißfestigkeit. Lieferbar im Durchmesserbereich 9,5 mm–35 mm. TiCN-Beschichtung für geringere Aufbauschneidenbildung in NE-Metallen. Gute Resultate bei vergüteten Stählen und größeren Bohrtiefen.**

*PVD-multilayer coating, HSS8 + TiCN  
 HSS with 8% cobalt contents, stock item from 9.5 mm–35 mm. TiCN coating has less tendency to "bulid up edge" in non-ferrous metals. Good results in hardened and tempered steels also for deeper drill depths.*

Rivestimento PVD-multistrato, HSS8 + TiCN  
 HSS con 8% di contenuto di Cobalto, disponibile da Dia 9,5 mm–35 mm. Il rivestimento TiCN molto più duro del rivestimento TiAlN offre una maggiore resistenza all'usura e una limitata tendenza alla formazione del tagliente di riporto. Idoneo anche per lavorare acciai duri oppure su fori profondi.

**Unbeschichtet / Uncoated / Non rivestito****AK20**

**K20 Hartmetall mit höherer Zähigkeit als AK10. Zur Bearbeitung sämtlicher Gusswerkstoffe, NE-Metalle, Titan und Titan-Legierungen. Geringere Neigung zur Aufbauschneidenbildung im NE-Bereich. Im Bohrbereich nur unter stabilen Schnittbedingungen einzusetzen.**

*K20 Carbide Grade with higher toughness as AK10 for machining all cast iron materials, non-ferrous metals, Titanium and Titanium Alloys. Less tendency for build-up edges in non-ferrous metals. Only for usage in a stable cutting-environment.*

Metallo duro grado K20 con maggiore tenacità rispetto ad AK10 per la lavorazione di tutte le ghise e materiali non ferrosi, Titanio e leghe di Titanio, materiali induriti fino a 55 HRC. Minore tendenza alla creazione del tagliente di riporto nei materiali non ferrosi. Solo per uso in stabili condizioni di lavorazione.

## Serie / Series / Serie

**A**

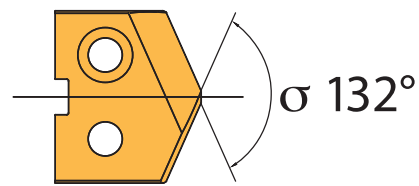

### Schneidplatten / Inserts / Inserti

Bezeichnung Designation Articolo	Durchmesser Diameter Diametro			beschichtet coated rivestito								unbeschichtet uncoated non rivestito	
	[mm]	[decimal]	[inch]	AK10 TiAlN	AK20 TiAlN	AP40 TiAlN	HSS TiN	HSS TiAlN	HSS 5 TiN	HSS 5 TiAlN	HSS 8 TiAlN	HSS 8 TiCN	AK 20
PA9.5	9,5	0,3740"		●	●	●				●	●	●	●
PA9.53	9,53	0,3750"	3/8							●			
PA9.8	9,8	0,3860"		●	●	●				●	●	●	●
PA9.92	9,92	0,3906"	25/64			●				●			
PA10	10,0	0,3937"		●	●	●				●	●	●	●
PA10.2	10,2	0,4016"		●	●	●				●	●	●	●
PA10.32	10,32	0,4060"	13/32							●			
PA10.5	10,5	0,4134"		●	●	●				●	●	●	●
PA10.72	10,72	0,4220"	27/64							●			
PA10.8	10,8	0,4252"		●	●	●				●	●	●	●
PA11	11,0	0,4331"		●	●	●				●	●	●	●

  

<p><b>Kleinste Verpackungseinheit: 2 Stück</b> Packed in two's = minimum quantity Confezione da 2 pezzi = Quantitativo minimo di acquisto</p>	<p>● <b>Hauptanwendung</b> Main Application Applicazione principale</p> <p>○ <b>Nebenanwendung</b> Secondary application Applicazione secondaria</p>	<table border="1"> <tr><td>P</td><td></td><td>○</td><td>●</td><td></td><td></td><td></td><td></td><td></td><td>●</td><td>●</td><td>●</td><td></td><td></td></tr> <tr><td>M</td><td></td><td></td><td></td><td>○</td><td></td><td></td><td></td><td></td><td>●</td><td>●</td><td></td><td>○</td><td></td></tr> <tr><td>K</td><td>●</td><td></td><td>●</td><td></td><td></td><td></td><td></td><td></td><td></td><td></td><td>○</td><td></td><td>●</td></tr> <tr><td>N</td><td></td><td></td><td>●</td><td></td><td></td><td></td><td></td><td></td><td></td><td></td><td></td><td>●</td><td>●</td></tr> <tr><td>S</td><td></td><td></td><td></td><td>○</td><td></td><td></td><td></td><td></td><td>○</td><td>●</td><td></td><td></td><td></td></tr> <tr><td>H</td><td></td><td></td><td></td><td></td><td></td><td></td><td></td><td></td><td></td><td></td><td></td><td></td><td></td></tr> </table>	P		○	●						●	●	●			M				○					●	●		○		K	●		●								○		●	N			●									●	●	S				○					○	●				H													
P		○	●						●	●	●																																																																											
M				○					●	●		○																																																																										
K	●		●								○		●																																																																									
N			●									●	●																																																																									
S				○					○	●																																																																												
H																																																																																						

1

## Serie / Series / Serie

**A**

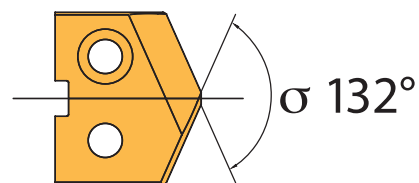

### Schneidplatten / Inserts / Inserti

#### AS Geometrie / Geometry / Geometria

Bezeichnung Designation Articolo	Durchmesser Diameter Diametro			beschichtet coated rivestito								unbeschichtet uncoated non rivestito	
	[mm]	[decimal]	[inch]	AK10 TiAlN	AK20 TiAlN	AP40 TiAlN	HSS TiN	HSS TiAlN	HSS 5 TiN	HSS 5 TiAlN	HSS 8 TiAlN	HSS 8 TiCN	AK 20
PA9.5-AS	9,5	0,3740"			●					●			
PA9.8-AS	9,8	0,3860"			●					●			
PA10-AS	10,0	0,3937"			●					●			
PA10.2-AS	10,2	0,4016"			●					●			
PA10.5-AS	10,5	0,4134"			●					●			
PA10.8-AS	10,8	0,4252"			●					●			
PA11-AS	11,0	0,4331"			●					●			

<p><b>Kleinste Verpackungseinheit: 2 Stück</b> Packed in two's = minimum quantity Confezione da 2 pezzi = Quantitativo minimo di acquisto</p> <p>“-AS” geometry not available for the US market.</p>	<p>● <b>Hauptanwendung</b> Main Application Applicazione principale</p> <p>○ <b>Nebenanwendung</b> Secondary application Applicazione secondaria</p>	<table border="1"> <tr><td>P</td><td></td><td>○</td><td></td><td></td><td></td><td></td><td></td><td></td><td>●</td><td></td><td></td><td></td><td></td></tr> <tr><td>M</td><td></td><td></td><td></td><td></td><td></td><td></td><td></td><td></td><td>●</td><td></td><td></td><td></td><td></td></tr> <tr><td>K</td><td></td><td></td><td>●</td><td></td><td></td><td></td><td></td><td></td><td></td><td></td><td></td><td></td><td></td></tr> <tr><td>N</td><td></td><td></td><td>●</td><td></td><td></td><td></td><td></td><td></td><td></td><td></td><td></td><td></td><td></td></tr> <tr><td>S</td><td></td><td></td><td></td><td>○</td><td></td><td></td><td></td><td></td><td>○</td><td></td><td></td><td></td><td></td></tr> <tr><td>H</td><td></td><td></td><td></td><td></td><td></td><td></td><td></td><td></td><td></td><td></td><td></td><td></td><td></td></tr> </table>	P		○							●					M									●					K			●											N			●											S				○					○					H													
P		○							●																																																																													
M									●																																																																													
K			●																																																																																			
N			●																																																																																			
S				○					○																																																																													
H																																																																																						

**Hinweis: Zwischenabmessungen, die hier nicht aufgeführt sind, schleifen und beschichten wir Ihnen ab 5 Stück ohne Mehrpreis!**

Remark: Other none standard diameters are available upon request.

Attenzione: Misure non indicate sono disponibili senza incremento prezzo per minimo 5pz.

## Serie / Series / Serie

**A**

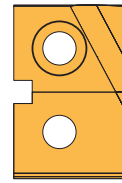

## Schneidplatten / Inserts / Inserti

### F Geometrie / Geometry / Geometria

Bezeichnung Designation Articolo	Durchmesser Diameter Diametro			beschichtet coated rivestito						unbeschichtet uncoated non rivestito			
	[mm]	[decimal]	[inch]	AK10 TiAlN	AK20 TiAlN	AP40 TiAlN	HSS TiN	HSS TiAlN	HSS 5 TiN	HSS 5 TiAlN	HSS 8 TiAlN	HSS 8 TiCN	AK 20
PA9.5-F	9,5	0,3740"								●			
PA9.8-F	9,8	0,3860"								●			
PA10-F	10,0	0,3937"								●			
PA10.2-F	10,2	0,4016"								●			
PA10.5-F	10,5	0,4134"								●			
PA10.8-F	10,8	0,4252"								●			
PA11-F	11,0	0,4331"								●			
Kleinste Verpackungseinheit: 2 Stück Packed in two's = minimum quantity Confezione da 2 pezzi = Quantitativo minimo di acquisto				<input checked="" type="radio"/> <b>Hauptanwendung</b> Main Application Applicazione principale				<input type="radio"/> <b>Nebenanwendung</b> Secondary application Applicazione secondaria					
				P						●			
				M						●			
				K	●	●					○		●
				N		●						●	●
				S		○			○	○	●		
				H									

## Serie / Series / Serie

**C**

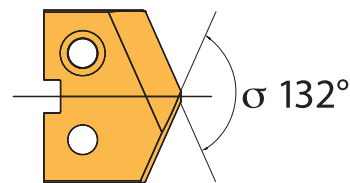

## Schneidplatten / Inserts / Inserti

Bezeichnung Designation Articolo	Durchmesser Diameter Diametro			beschichtet coated rivestito						unbeschichtet uncoated non rivestito			
	[mm]	[decimal]	[inch]	AK10 TiAlN	AK20 TiAlN	AP40 TiAlN	HSS TiN	HSS TiAlN	HSS 5 TiN	HSS 5 TiAlN	HSS 8 TiAlN	HSS 8 TiCN	AK 20
PC11.11	11,11	0,4375"	7/16							●			
PC11.5	11,5	0,4528"		●	●	●				●	●	●	●
PC11.51	11,51	0,4530"	29/64							●			
PC11.55	11,55	0,4547"			●								
PC11.8	11,8	0,4646"				●							
PC11.91	11,91	0,4690"	15/32							●			
PC12	12,0	0,4724"		●	●	●			●	●	●	●	●
PC12.3	12,3	0,4844"	31/64							●			
PC12.5	12,5	0,4921"		●	●	●				●	●	●	●
PC12.7	12,7	0,5000"	1/2							●			
PC12.8	12,8	0,5039"		●	●	●				●	●	●	●
Kleinste Verpackungseinheit: 2 Stück Packed in two's = minimum quantity Confezione da 2 pezzi = Quantitativo minimo di acquisto				<input checked="" type="radio"/> <b>Hauptanwendung</b> Main Application Applicazione principale				<input type="radio"/> <b>Nebenanwendung</b> Secondary application Applicazione secondaria					
				P		○	●		●	●	●	●	
				M					●	●	●	○	
				K	●	●					○		●
				N		●						●	●
				S		○			○	○	●		
				H									

Hinweis: Zwischenabmessungen, die hier nicht aufgeführt sind, schleifen und beschichten wir Ihnen ab 5 Stück ohne Mehrpreis!

Remark: Other none standard diameters are available upon request.

Attenzione: Misure non indicate sono disponibili senza incremento prezzo per minimo 5pz.



## Serie / Series / Serie

C

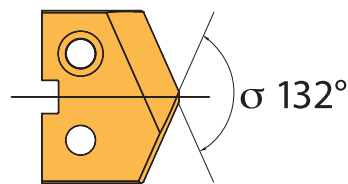

## Schneidplatten / Inserts / Inserti

### AS Geometrie / Geometry / Geometria

Bezeichnung Designation Articolo	Durchmesser Diameter Diametro			beschichtet coated rivestito							unbeschichtet uncoated non rivestito			
	[mm]	[decimal]	[inch]	AK10 TiAlN	AK20 TiAlN	AP40 TiAlN	HSS TiN	HSS TiAlN	HSS 5 TiN	HSS 5 TiAlN	HSS 8 TiAlN	HSS 8 TiCN	AK 20	
PC11.5-AS	11,5	0,4528"			●					●				
PC12-AS	12,0	0,4724"			●					●				
PC12.5-AS	12,5	0,4921"			●					●				
PC12.8-AS	12,8	0,5039"			●					●				
Kleinste Verpackungseinheit: 2 Stück Packed in two's = minimum quantity Confezione da 2 pezzi = Quantitativo minimo di acquisto				● Hauptanwendung Main Application Applicazione principale				P			○			
								M			●			
"AS" geometry not available for the US market.				○ Nebenanwendung Secondary application Applicazione secondaria				K			●			
								N			●			
								S			○			
								H						

## Serie / Series / Serie

C



## Schneidplatten / Inserts / Inserti

### F Geometrie / Geometry / Geometria

Bezeichnung Designation Articolo	Durchmesser Diameter Diametro			beschichtet coated rivestito							unbeschichtet uncoated non rivestito			
	[mm]	[decimal]	[inch]	AK10 TiAlN	AK20 TiAlN	AP40 TiAlN	HSS TiN	HSS TiAlN	HSS 5 TiN	HSS 5 TiAlN	HSS 8 TiAlN	HSS 8 TiCN	AK 20	
PC11.5-F	11,5	0,4528"								●				
PC12-F	12,0	0,4724"								●				
PC12.5-F	12,5	0,4921"								●				
PC12.8-F	12,8	0,5039"								●				
Kleinste Verpackungseinheit: 2 Stück Packed in two's = minimum quantity Confezione da 2 pezzi = Quantitativo minimo di acquisto				● Hauptanwendung Main Application Applicazione principale				P			○			
								M			●			
				○ Nebenanwendung Secondary application Applicazione secondaria				K						
								N						
								S			○			
								H						

Hinweis: Zwischenabmessungen, die hier nicht aufgeführt sind, schleifen und beschichten wir Ihnen ab 5 Stück ohne Mehrpreis!

Remark: Other none standard diameters are available upon request.

Attenzione: Misure non indicate sono disponibili senza incremento prezzo per minimo 5pz.

## Serie / Series / Serie E + G

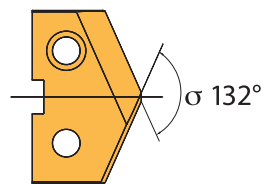

### Schneidplatten / Inserts / Inserti

1

Bezeichnung Designation Articolo	Durchmesser Diameter Diametro			beschichtet coated rivestito								unbeschichtet uncoated non rivestito	
	[mm]	[decimal]	[inch]	AK10 TiAlN	AK20 TiAlN	AP40 TiAlN	HSS TiN	HSS TiAlN	HSS 5 TiN	HSS 5 TiAlN	HSS 8 TiAlN	HSS 8 TiCN	AK 20
PE13	13,0	0,5118"		●	●	●				●	●	●	●
PE13.1	13,1	0,5156"	33/64		●					●			
PE13.15	13,15	0,5177"									●		
PE13.49	13,49	0,5310"	17/32							●			
PE13.5	13,5	0,5315"		●	●	●				●	●	●	●
PE13.8	13,8	0,5433"		●	●	●				●	●	●	●
PE14	14,0	0,5512"		●	●	●			●	●	●	●	●
PE14.29	14,29	0,5626"	9/16							●			
PE14.3	14,3	0,5630"			●								
PE14.5	14,5	0,5709"		●	●	●				●	●	●	●
PE14.68	14,68	0,5779"	37/64							●			
PE14.8	14,8	0,5827"		●	●	●				●	●	●	●
PE15	15,0	0,5906"		●	●	●				●	●	●	●
PE15.08	15,08	0,5940"	19/32							●			
PE15.2	15,2	0,5984"								●			
PE15.5*	15,5	0,6102"		●	●	●				●	●	●	●
PE15.8*	15,8	0,6220"		●	●	●				●	●	●	●
PE15.88*	15,88	0,6252"	5/8							●			
PE16*	16,0	0,6299"		●	●	●			●	●	●	●	●
PE16.05*	16,05	0,6319"							●				
PE16.1*	16,1	0,6339"				●			●				
PE16.27*	16,27	0,6406"	41/64							●	●		
PE16.3*	16,3	0,6417"			●								
PE16.5*	16,5	0,6496"		●	●	●				●	●	●	●
PE16.67*	16,67	0,6563"	21/32							●			
PE16.8*	16,8	0,6614"		●	●	●				●	●	●	●
PE17*	17,0	0,6693"		●	●	●				●	●	●	●
PE17.46*	17,46	0,6870"	11/16							●			
PE17.5*	17,5	0,6890"		●	●	●				●	●	●	●
PE17.86*	17,86	0,7030"								●			

\* Schneidplatten passend für Halter der Serie E und G  
\* Inserts for use in holders serie E and G  
\* Inserto per corpi serie E e G

Kleinste Verpackungseinheit: 2 Stück  
Packed in two's = minimum quantity  
Confezione da 2 pezzi = Quantitativo minimo di acquisto

● Hauptanwendung  
Main Application  
Applicazione principale

○ Nebenanwendung  
Secondary application  
Applicazione secondaria

	P	M	K	N	S	H
● Hauptanwendung	○	○	○	○	○	○
○ Nebenanwendung	●	●	●	●	●	●

Hinweis: Zwischenabmessungen, die hier nicht aufgeführt sind, schleifen und beschichten wir Ihnen ab 5 Stück ohne Mehrpreis!

Remark: Other none standard diameters are available upon request.

Attenzione: Misure non indicate sono disponibili senza incremento prezzo per minimo 5pz.

## Serie / Series / Serie E + G

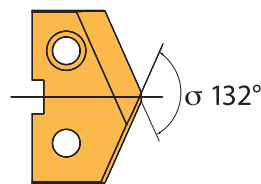

### Schneidplatten / Inserts / Inserti AS Geometrie / Geometry / Geometria

Bezeichnung Designation Articolo	Durchmesser Diameter Diametro			beschichtet coated rivestito								unbeschichtet uncoated non rivestito	
	[mm]	[decimal]	[inch]	AK10 TiAlN	AK20 TiAlN	AP40 TiAlN	HSS TiN	HSS TiAlN	HSS 5 TiN	HSS 5 TiAlN	HSS 8 TiAlN	HSS 8 TiCN	AK 20
PE13-AS	13,0	0,5118"			●						●		
PE13.5-AS	13,5	0,5315"			●						●		
PE13.8-AS	13,8	0,5433"			●						●		
PE14-AS	14,0	0,5512"			●						●		
PE14.5-AS	14,5	0,5709"			●						●		
PE14.8-AS	14,8	0,5827"			●						●		
PE15-AS	15,0	0,5906"			●						●		
PE15.5-AS*	15,5	0,6102"			●						●		
PE15.8-AS*	15,8	0,6220"			●						●		
PE16-AS*	16,0	0,6299"			●						●		
PE16.5-AS*	16,5	0,6496"			●						●		
PE16.8-AS*	16,8	0,6614"			●						●		
PE17-AS*	17,0	0,6693"			●						●		
PE17.5-AS*	17,5	0,6890"			●						●		

\* Schneidplatten passend für Halter der Serie E und G  
\* Inserts for use in holders serie E and G  
\* Inserto per corpi serie E e G

Kleinste Verpackungseinheit: 2 Stück  
Packed in two's = minimum quantity  
Confezione da 2 pezzi = Quantitativo minimo di acquisto

"-AS" geometry not available for the US market.

● Hauptanwendung  
Main Application  
Applicazione principale

○ Nebenanwendung  
Secondary application  
Applicazione secondaria

	P	M	K	N	S	H
● Hauptanwendung	○		●	●	○	
○ Nebenanwendung						



Hinweis: Zwischenabmessungen, die hier nicht aufgeführt sind, schleifen und beschichten wir Ihnen ab 5 Stück ohne Mehrpreis!

Remark: Other none standard diameters are available upon request.

Attenzione: Misure non indicate sono disponibili senza incremento prezzo per minimo 5pz.

## Serie / Series / Serie E + G

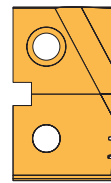

### Schneidplatten / Inserts / Inserti F Geometrie / Geometry / Geometria

1

Bezeichnung Designation Articolo	Durchmesser Diameter Diametro			beschichtet coated rivestito							unbeschichtet uncoated non rivestito		
	[mm]	[decimal]	[inch]	AK10 TiAlN	AK20 TiAlN	AP40 TiAlN	HSS TiN	HSS TiAlN	HSS 5 TiN	HSS 5 TiAlN	HSS 8 TiAlN	HSS 8 TiCN	AK 20
PE13-F	13,0	0,5118"								●			
PE13.5-F	13,5	0,5315"								●			
PE13.8-F	13,8	0,5433"								●			
PE14-F	14,0	0,5512"								●			
PE14.5-F	14,5	0,5709"								●			
PE14.8-F	14,8	0,5827"								●			
PE15-F	15,0	0,5906"								●			
PE15.5-F*	15,5	0,6102"								●			
PE15.8-F*	15,8	0,6220"								●			
PE16-F*	16,0	0,6299"								●			
PE16.5-F*	16,5	0,6496"						●		●			
PE16.8-F*	16,8	0,6614"								●			
PE17-F*	17,0	0,6693"								●			
PE17.5-F*	17,5	0,6890"								●			

\* Schneidplatten passend für Halter der Serie E und G  
\* Inserts for use in holders serie E and G  
\* Inserto per corpi serie E e G

Kleinste Verpackungseinheit: 2 Stück  
Packed in two's = minimum quantity  
Confezione da 2 pezzi = Quantitativo minimo di acquisto

- Hauptanwendung  
Main Application  
Applicazione principale
- Nebenanwendung  
Secondary application  
Applicazione secondaria

P								●	●				
M								●	●				
K													
N													
S								○	○				
H													

Hinweis: Zwischenabmessungen, die hier nicht aufgeführt sind, schleifen und beschichten wir Ihnen ab 5 Stück ohne Mehrpreis!

Remark: Other none standard diameters are available upon request.

Attenzione: Misure non indicate sono disponibili senza incremento prezzo per minimo 5pz.

## Serie / Series / Serie I + K

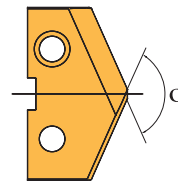

### Schneidplatten / Inserts / Inserti

Bezeichnung Designation Articolo	Durchmesser Diameter Diametro			beschichtet coated rivestito								unbeschichtet uncoated non rivestito	
	[mm]	[decimal]	[inch]	AK10 TiAlN	AK20 TiAlN	AP40 TiAlN	HSS TiN	HSS TiAlN	HSS 5 TiN	HSS 5 TiAlN	HSS 8 TiAlN	HSS 8 TiCN	AK 20
PI17.5	17,5	0,6890"											
PI17.8	17,8	0,7008"		•	•	•			•	•	•	•	•
PI17.86	17,86	0,7030"	45/64							•			
PI18	18,0	0,7087"		•	•	•		•		•	•	•	•
PI18.26	18,26	0,7190"	23/32							•			
PI18.5	18,5	0,7283"		•	•	•				•	•	•	•
PI18.65	18,65	0,7343"	47/64							•			
PI18.8	18,8	0,7402"		•	•	•				•	•	•	•
PI19	19,0	0,7480"		•	•	•		•		•	•	•	•
PI19.05	19,05	0,7500"	3/4							•		•	
PI19.45	19,45	0,7660"	49/64							•			
PI19.5	19,5	0,7677"		•	•	•		•		•	•	•	•
PI19.8	19,8	0,7795"		•	•	•	•			•	•	•	•
PI19.84	19,84	0,7811"	25/32							•			
PI19.95	19,95	0,7854"					•						
PI20	20,0	0,7874"		•	•	•	•	•		•	•	•	•
PI20.15	20,15	0,7933"					•						
PI20.2	20,2	0,7953"					•						
PI20.5	20,5	0,8071"		•	•	•	•			•	•	•	•
PI20.64	20,64	0,8130"	13/16							•			
PI20.7	20,7	0,8150"		•	•	•				•	•	•	•
PI21	21,0	0,8268"		•	•	•		•		•	•	•	•
PI21.43	21,43	0,8437"	27/32							•			
PI21.5	21,5	0,8465"		•	•	•				•	•	•	•
PI21.7	21,7	0,8543"		•	•	•				•	•	•	•
PI21.95	21,95	0,8642"					•						
PI22*	22,0	0,8661"		•	•	•	•	•		•	•	•	•
PI22.23*	22,23	0,8750"	7/8				•			•			
PI22.4*	22,4	0,8819"						•					
PI22.5*	22,5	0,8858"		•	•	•				•	•	•	•
PI22.62*	22,62	0,8906"								•			
PI22.7*	22,7	0,8937"		•	•	•				•	•	•	•
PI23*	23,0	0,9055"		•	•	•				•	•	•	•
PI23.02*	23,02	0,9060"	29/32							•			
PI23.42*	23,42	0,9220"	59/64							•			
PI23.5*	23,5	0,9252"		•	•	•		•		•	•	•	•
PI23.7*	23,7	0,9331"		•	•	•				•	•	•	•
PI23.81*	23,81	0,9370"	15/16							•			
PI24*	24,0	0,9449"		•	•	•		•		•	•	•	•
PI24.21*	24,21	0,9531"						•					

\* Schneidplatten passend für Halter der Serie I und K  
\* Inserts for use in holders serie I and K  
\* Inserto per corpi serie I e K

• Hauptanwendung  
Main Application  
Applicazione principale

○ Nebenanwendung  
Secondary application  
Applicazione secondaria

P		○	•	•	•	•	•	•	•	•	•	•	
M			○	○	○	•	•	•	•	•	○		
K	•	•								○		•	
N		•									•		•
S		○						○	○	•			
H													

Hinweis: Zwischenabmessungen, die hier nicht aufgeführt sind, schleifen und beschichten wir Ihnen ab 5 Stück ohne Mehrpreis!

Remark: Other none standard diameters are available upon request.

Attenzione: Misure non indicate sono disponibili senza incremento prezzo per minimo 5pz.



## Serie / Series / Serie I + K

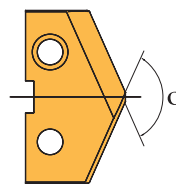

### Schneidplatten / Inserts / Inserti AS Geometrie / Geometry / Geometria

1

Bezeichnung Designation Articolo	Durchmesser Diameter Diametro			beschichtet coated rivestito							unbeschichtet uncoated non rivestito		
	[mm]	[decimal]	[inch]	AK10 TiAlN	AK20 TiAlN	AP40 TiAlN	HSS TiN	HSS TiAlN	HSS 5 TiN	HSS 5 TiAlN	HSS 8 TiAlN	HSS 8 TiCN	AK 20
PI17.8-AS	17,8	0,7008"			●					●			
PI18-AS	18,0	0,7087"			●					●			
PI18.5-AS	18,5	0,7283"			●					●			
PI18.8-AS	18,8	0,7402"			●					●			
PI19-AS	19,0	0,7480"			●					●			
PI19.5-AS	19,5	0,7677"			●					●			
PI19.8-AS	19,8	0,7795"			●					●			
PI20-AS	20,0	0,7874"			●					●			
PI20.5-AS	20,5	0,8071"			●					●			
PI20.7-AS	20,7	0,8150"			●					●			
PI21-AS	21,0	0,8268"			●					●			
PI21.5-AS	21,5	0,8465"			●					●			
PI21.7-AS	21,7	0,8543"			●					●			
PI22-AS*	22,0	0,8661"			●					●			
PI22.5-AS*	22,5	0,8858"			●					●			
PI22.7-AS*	22,7	0,8937"			●					●			
PI23-AS*	23,0	0,9055"			●					●			
PI23.5-AS*	23,5	0,9252"			●					●			
PI23.7-AS*	23,7	0,9331"			●					●			
PI24-AS*	24,0	0,9449"			●					●			

\* Schneidplatten passend für Halter der Serie I und K  
\* Inserts for use in holders serie I and K  
\* Inserto per corpi serie I e K

"AS" geometry not available for the US market.

- Hauptanwendung  
Main Application  
Applicazione principale
- Nebenanwendung  
Secondary application  
Applicazione secondaria

P	○		●										
M										●			
K			●										
N			●										
S	○								○				
H													

Hinweis: Zwischenabmessungen, die hier nicht aufgeführt sind, schleifen und beschichten wir Ihnen ab 5 Stück ohne Mehrpreis!

Remark: Other none standard diameters are available upon request.

Attenzione: Misure non indicate sono disponibili senza incremento prezzo per minimo 5pz.

## Serie / Series / Serie I + K

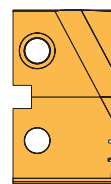

### Schneidplatten / Inserts / Inserti F Geometrie / Geometry / Geometria

Bezeichnung Designation Articolo	Durchmesser Diameter Diametro			beschichtet coated rivestito								unbeschichtet uncoated non rivestito	
	[mm]	[decimal]	[inch]	AK10 TiAlN	AK20 TiAlN	AP40 TiAlN	HSS TiN	HSS TiAlN	HSS 5 TiN	HSS 5 TiAlN	HSS 8 TiAlN	HSS 8 TiCN	AK 20
PI17.8-F	17,8	0,7008"								●			
PI18-F	18,0	0,7087"								●			
PI18.5-F	18,5	0,7283"								●			
PI18.8-F	18,8	0,7402"								●			
PI19-F	19,0	0,7480"								●			
PI19.5-F	19,5	0,7677"								●			
PI19.8-F	19,8	0,7795"								●			
PI20-F	20,0	0,7874"								●			
PI20.5-F	20,5	0,8071"								●			
PI20.7-F	20,7	0,8150"								●			
PI21-F	21,0	0,8268"								●			
PI21.5-F	21,5	0,8465"								●			
PI21.7-F	21,7	0,8543"								●			
PI22-F*	22,0	0,8661"								●			
PI22.5-F*	22,5	0,8858"								●			
PI22.7-F*	22,7	0,8937"								●			
PI23-F*	23,0	0,9055"								●			
PI23.5-F*	23,5	0,9252"								●			
PI23.7-F*	23,7	0,9331"								●			
PI24-F*	24,0	0,9449"								●			

\* Schneidplatten passend für Halter der Serie I und K  
\* Inserts for use in holders serie I and K  
\* Inserto per corpi serie I e K

- Hauptanwendung  
Main Application  
Applicazione principale
- Nebenanwendung  
Secondary application  
Applicazione secondaria

P	●	
M	●	
K		
N		
S	○	
H		

Hinweis: Zwischenabmessungen, die hier nicht aufgeführt sind, schleifen und beschichten wir Ihnen ab 5 Stück ohne Mehrpreis!

Remark: Other none standard diameters are available upon request.

Attenzione: Misure non indicate sono disponibili senza incremento prezzo per minimo 5pz.



## Serie / Series / Serie M + O

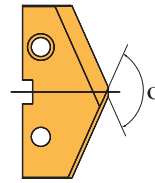

### Schneidplatten / Inserts / Inserti

1

Bezeichnung Designation Articolo	Durchmesser Diameter Diametro			beschichtet coated rivestito								unbeschichtet uncoated non rivestito	
	[mm]	[decimal]	[inch]	AK10 TiAlN	AK20 TiAlN	AP40 TiAlN	HSS TiN	HSS TiAlN	HSS 5 TiN	HSS 5 TiAlN	HSS 8 TiAlN	HSS 8 TiCN	AK 20
PM24.5	24,5	0,9646"		●	●	●				●	●	●	●
PM24.61	24,61	0,9688"	31/32	●			●			●			
PM24.7	24,7	0,9724"					●						
PM24.85	24,85	0,9783"					●						
PM24.95	24,95	0,9823"					●						
PM25	25,0	0,9843"	63/64	●	●	●	●	●		●	●	●	●
PM25.4	25,4	1,0000"	1							●			
PM25.5	25,5	1,0040"		●	●	●				●	●	●	●
PM25.7	25,7	1,0118"								●			
PM25.8	25,8	1,0157"	1 1/64							●			
PM26	26,0	1,0236"		●	●	●	●	●		●	●	●	●
PM26.19	26,19	1,0313"	1 1/32				●	●					
PM26.5	26,5	1,0433"		●	●	●				●	●	●	●
PM26.6	26,6	1,0472"					●						
PM26.7	26,7	1,0512"					●						
PM26.8	26,8	1,0551"			●								
PM26.99	26,99	1,0630"								●			
PM27	27,0	1,0630"	1 1/16	●	●	●	●	●		●	●	●	●
PM27.4	27,4	1,0787"						●					
PM27.5	27,5	1,0827"		●	●	●	●			●	●	●	●
PM27.7	27,7	1,0906"					●						
PM27.78	27,78	1,0938"	1 3/32				●	●					
PM27.8	27,8	1,0945"					●						
PM28	28,0	1,1024"		●	●	●	●	●		●	●	●	●
PM28.3	28,3	1,1141"					●						
PM28.5	28,5	1,1220"		●	●	●				●	●	●	●
PM28.58	28,58	1,1252"	1 1/8							●			
PM29	29,0	1,1417"		●	●	●	●	●		●	●	●	●
PM29.37	29,37	1,1563"	1 5/32				●						
PM29.5	29,5	1,1614"		●	●	●	●			●	●	●	●
PM29.9	29,9	1,1772"					●						
PM30*	30,0	1,1811"		●	●	●	●	●		●	●	●	●
PM30.16*	30,16	1,1874"	1 3/16							●			
PM30.5*	30,5	1,2007"		●	●	●		●		●	●	●	●
PM30.7*	30,7	1,2087"								●			
PM30.96*	30,96	1,2190"	1 7/32							●			
PM31*	31,0	1,2205"		●	●	●	●	●		●	●	●	●
PM31.5*	31,5	1,2402"		●	●	●				●	●	●	●

\* Schneidplatten passend für Halter der Serie M und O  
\* Inserts for use in holders serie M and O  
\* Inserto per corpi serie M e O

● Hauptanwendung  
Main Application  
Applicazione principale

○ Nebenanwendung  
Secondary application  
Applicazione secondaria

	P	M	K	N	S	H
● Hauptanwendung	○	●	●	●	●	●
○ Nebenanwendung	●	●			○	●
		○	○	○	○	
					○	●

Hinweis: Zwischenabmessungen, die hier nicht aufgeführt sind, schleifen und beschichten wir Ihnen ab 5 Stück ohne Mehrpreis!

Remark: Other none standard diameters are available upon request.

Attenzione: Misure non indicate sono disponibili senza incremento prezzo per minimo 5pz.



## Schneidplatten / Inserts / Inserti

Bezeichnung Designation Articolo	Durchmesser Diameter Diametro			beschichtet coated rivestito								unbeschichtet uncoated non rivestito	
	[mm]	[decimal]	[inch]	AK10 TiAlN	AK20 TiAlN	AP40 TiAlN	HSS TiN	HSS TiAlN	HSS 5 TiN	HSS 5 TiAlN	HSS 8 TiAlN	HSS 8 TiCN	AK 20
PM31.7	31,7	1,2480"					●						
PM31.75*	31,75	1,2500"	1 1/4				●	●		●			
PM32*	32,0	1,2598"		●	●	●	●	●		●	●	●	●
PM32.5*	32,5	1,2795"		●	●	●		●		●	●	●	●
PM32.54*	32,54	1,2813"	1 9/32				●						
PM33*	33,0	1,2992"		●	●	●		●		●	●	●	●
PM33.34*	33,34	1,3130"	1 5/16							●			
PM33.5*	33,5	1,3189"		●	●	●				●	●	●	●
PM33.7*	33,7	1,3268"											●
PM34*	34,0	1,3386"		●	●	●	●	●		●	●	●	●
PM34.13*	34,13	1,3438"	1 11/32				●	●		●			
PM34.5*	34,5	1,3583"		●		●	●			●	●	●	●
PM34.7*	34,7	1,3661"								●			
PM34.93*	34,93	1,3752"	1 3/8							●			
PM35*	35,0	1,3780"		●	●	●	●	●		●	●	●	●

* Schneidplatten passend für Halter der Serie M und O * Inserts for use in holders serie M and O * Inserto per corpi serie M e O	● Hauptanwendung Main Application Applicazione principale	P		○	●	●	●	●	●	●	●		
	○ Nebenanwendung Secondary application Applicazione secondaria	M			○	○	○		●	●	○		
		K	●	●							○		●
		N		●								●	●
		S		○						○	●		
		H											

Hinweis: Zwischenabmessungen, die hier nicht aufgeführt sind, schleifen und beschichten wir Ihnen ab 5 Stück ohne Mehrpreis!

Remark: Other none standard diameters are available upon request.

Attenzione: Misure non indicate sono disponibili senza incremento prezzo per minimo 5pz.



## Serie / Series / Serie M + O

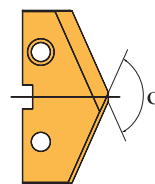

### Schneidplatten / Inserts / Inserti AS Geometrie / Geometry / Geometria

1

Bezeichnung Designation Articolo	Durchmesser Diameter Diametro			beschichtet coated rivestito								unbeschichtet uncoated non rivestito	
	[mm]	[decimal]	[inch]	AK10 TiAlN	AK20 TiAlN	AP40 TiAlN	HSS TiN	HSS TiAlN	HSS 5 TiN	HSS 5 TiAlN	HSS 8 TiAlN	HSS 8 TiCN	AK 20
PM24.5-AS	24,5	0,9646"			●					●			
PM25-AS	25,0	0,9843"	63/64		●					●			
PM25.5-AS	25,5	1,0040"			●					●			
PM26-AS	26,0	1,0236"			●					●			
PM26.5-AS	26,5	1,0433"			●					●			
PM27-AS	27,0	1,0630"	1 1/16		●					●			
PM27.5-AS	27,5	1,0827"			●					●			
PM28-AS	28,0	1,1024"			●					●			
PM28.5-AS	28,5	1,1220"			●					●			
PM29-AS	29,0	1,1417"			●					●			
PM29.5-AS	29,5	1,1614"			●					●			
PM30-AS*	30,0	1,1811"			●					●			
PM30.5-AS*	30,5	1,2007"			●					●			
PM31-AS*	31,0	1,2205"			●					●			
PM31.5-AS*	31,5	1,2402"			●					●			
PM32-AS*	32,0	1,2598"			●					●			
PM32.5-AS*	32,5	1,2795"			●					●			
PM33-AS*	33,0	1,2992"			●					●			
PM33.5-AS*	33,5	1,3189"			●					●			
PM34-AS*	34,0	1,3386"			●					●			
PM34.5-AS*	34,5	1,3583"			●					●			
PM35-AS*	35,0	1,3780"			●					●			

\* Schneidplatten passend für Halter der Serie M und O

\* Inserts for use in holders serie M and O

\* Inserto per corpi serie M e O

"-AS" geometry not available for the US market.

● Hauptanwendung

Main Application

Applicazione principale

○ Nebenanwendung

Secondary application

Applicazione secondaria

P	○	●	
M		●	
K	●		
N	●		
S	○		○
H			

Hinweis: Zwischenabmessungen, die hier nicht aufgeführt sind, schleifen und beschichten wir Ihnen ab 5 Stück ohne Mehrpreis!

Remark: Other none standard diameters are available upon request.

Attenzione: Misure non indicate sono disponibili senza incremento prezzo per minimo 5pz.

## Serie / Series / Serie M + O

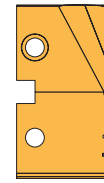

### Schneidplatten / Inserts / Inserti F Geometrie / Geometry / Geometria

Bezeichnung Designation Articolo	Durchmesser Diameter Diametro			beschichtet coated rivestito								unbeschichtet uncoated non rivestito	
	[mm]	[decimal]	[inch]	AK10 TiAlN	AK20 TiAlN	AP40 TiAlN	HSS TiN	HSS TiAlN	HSS 5 TiAlN	HSS 5 TiAlN	HSS 8 TiAlN	HSS 8 TiCN	AK 20
PM24.5-F	24,5	0,9646"								●			
PM25-F	25,0	0,9843"	63/64							●			
PM25.5-F	25,5	1,0040"								●			
PM26-F	26,0	1,0236"								●			
PM26.5-F	26,5	1,0433"								●			
PM27-F	27,0	1,0630"	1 1/16							●			
PM27.5-F	27,5	1,0827"								●			
PM28-F	28,0	1,1024"								●			
PM28.5-F	28,5	1,1220"								●			
PM29-F	29,0	1,1417"								●			
PM29.5-F	29,5	1,1614"								●			
PM30-F*	30,0	1,1811"								●			
PM30.5-F*	30,5	1,2007"								●			
PM31-F*	31,0	1,2205"								●			
PM31.5-F*	31,5	1,2402"								●			
PM31.75-F*	31,75	1,2500"	1 1/4							●			
PM32-F*	32,0	1,2598"								●			
PM32.5-F*	32,5	1,2795"								●			
PM33-F*	33,0	1,2992"								●			
PM33.5-F*	33,5	1,3189"								●			
PM34-F*	34,0	1,3386"								●			
PM34.5-F*	34,5	1,3583"								●			
PM35-F*	35,0	1,3780"								●			
* Schneidplatten passend für Halter der Serie M und O * Inserts for use in holders serie M and O * Inserto per corpi serie M e O				<ul style="list-style-type: none"> <li>● <b>Hauptanwendung</b> Main Application Applicazione principale</li> <li>○ <b>Nebenanwendung</b> Secondary application Applicazione secondaria</li> </ul>									
				<b>P</b>						●			
				<b>M</b>						●			
				<b>K</b>									
				<b>N</b>									
				<b>S</b>						○			
				<b>H</b>									

Hinweis: Zwischenabmessungen, die hier nicht aufgeführt sind, schleifen und beschichten wir Ihnen ab 5 Stück ohne Mehrpreis!

Remark: Other none standard diameters are available upon request.

Attenzione: Misure non indicate sono disponibili senza incremento prezzo per minimo 5pz.



## Serie / Series / Serie

Q

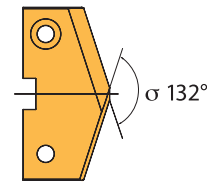

## Schneidplatten / Inserts / Inserti

1

Bezeichnung Designation Articolo	Durchmesser Diameter Diametro			beschichtet coated rivestito							unbeschichtet uncoated non rivestito		
	[mm]	[decimal]	[inch]	AK10 TiAlN	AK20 TiAlN	AP40 TiAlN	HSS TiN	HSS TiAlN	HSS 5 TiN	HSS 5 TiAlN	HSS 8 TiAlN	HSS 8 TiCN	AK 20
PQ35	35,0	1,3780"								●			
PQ35.7	35,7	1,4005"						●					
PQ35.72	35,72	1,4063"	1 13/32							●			
PQ36	36,0	1,4173"		●	●		●	●		●			
PQ36.5	36,5	1,4370"				●							
PQ36.51	36,51	1,4375"	1 7/16				●						
PQ37	37,0	1,4567"		●	●			●		●			
PQ37.5	37,5	1,4764"								●			
PQ38	38,0	1,4961"		●	●			●		●			
PQ38.1	38,1	1,5000"	1 1/5							●			
PQ38.5	38,5	1,5157"								●			
PQ38.89	38,89	1,5311"	1 17/32							●			
PQ39	39,0	1,5354"		●	●		●	●		●			
PQ39.5	39,5	1,5551"								●			
PQ39.69	39,69	1,5625"	1 9/16				●	●					
PQ40	40,0	1,5748"		●	●			●		●			
PQ41	41,0	1,6142"		●	●			●		●			
PQ41.28	41,28	1,6250"	1 5/8							●			
PQ41.5	41,5	1,6339"								●			
PQ42	42,0	1,6535"		●	●		●	●		●			
PQ42.07	42,07	1,6563"	1 21/32				●						
PQ42.3	42,3	1,6654"								●			
PQ42.5	42,5	1,6732"					●	●					
PQ42.86	42,86	1,6875"	1 11/16				●						
PQ43	43,0	1,6929"		●	●		●			●			
PQ43.33	43,33	1,7059"								●			
PQ44	44,0	1,7323"		●	●			●		●			
PQ44.45	44,45	1,7500"	1 3/4							●			
PQ45	45,0	1,7717"		●	●			●		●			
PQ45.24	45,24	1,7811"	1 25/32							●			
PQ46	46,0	1,8110"		●	●			●		●			
PQ46.83	46,83	1,8438"	1 27/32				●	●					
PQ47	47,0	1,8504"		●	●		●	●		●			
PQ47.62	47,62	1,8748"								●			

● Hauptanwendung Main Application Applicazione principale	P	○	●	●	●	●	○
○ Nebenanwendung Secondary application Applicazione secondaria	K	●					
	N	●					
	S	○				○	
	H						

Hinweis: Zwischenabmessungen, die hier nicht aufgeführt sind, schleifen und beschichten wir Ihnen ab 5 Stück ohne Mehrpreis!

Remark: Other none standard diameters are available upon request.

Attenzione: Misure non indicate sono disponibili senza incremento prezzo per minimo 5pz.

## Serie / Series / Serie

Q

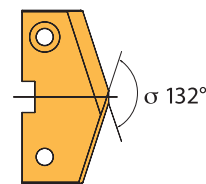

## Schneidplatten / Inserts / Inserti

### AS Geometrie / Geometry / Geometria

Bezeichnung Designation Articolo	Durchmesser Diameter Diametro			beschichtet coated rivestito							unbeschichtet uncoated non rivestito		
	[mm]	[decimal]	[inch]	AK10 TiAlN	AK20 TiAlN	AP40 TiAlN	HSS TiN	HSS TiAlN	HSS 5 TiAlN	HSS 5 TiAlN	HSS 8 TiAlN	HSS 8 TiCN	AK 20
PQ38-AS	38,0	1,4961"								●			
PQ39-AS	39,0	1,5354"								●			
PQ40-AS	40,0	1,5748"								●			
PQ41-AS	41,0	1,6142"								●			
PQ42-AS	42,0	1,6535"								●			
PQ43-AS	43,0	1,6929"								●			
PQ44-AS	44,0	1,7323"								●			
PQ45-AS	45,0	1,7717"								●			
"AS" geometry not available for the US market.													
● Hauptanwendung Main Application Applicazione principale				P						●			
				M						●			
○ Nebenanwendung Secondary application Applicazione secondaria				K									
				N									
				S						○			
				H									

## Serie / Series / Serie

Q



## Schneidplatten / Inserts / Inserti

### F Geometrie / Geometry / Geometria

Bezeichnung Designation Articolo	Durchmesser Diameter Diametro			beschichtet coated rivestito							unbeschichtet uncoated non rivestito		
	[mm]	[decimal]	[inch]	AK10 TiAlN	AK20 TiAlN	AP40 TiAlN	HSS TiN	HSS TiAlN	HSS 5 TiAlN	HSS 5 TiAlN	HSS 8 TiAlN	HSS 8 TiCN	AK 20
PQ36-F	36,0	1,4173"								●			
PQ37-F	37,0	1,4567"								●			
PQ38-F	38,0	1,4961"								●			
PQ39-F	39,0	1,5354"								●			
PQ40-F	40,0	1,5748"								●			
PQ41-F	41,0	1,6142"								●			
PQ42-F	42,0	1,6535"								●			
PQ43-F	43,0	1,6929"								●			
PQ44-F	44,0	1,7323"								●			
PQ45-F	45,0	1,7717"								●			
PQ46-F	46,0	1,8110"								●			
PQ47-F	47,0	1,8504"								●			
● Hauptanwendung Main Application Applicazione principale				P						●			
				M						●			
○ Nebenanwendung Secondary application Applicazione secondaria				K									
				N									
				S						○			
				H									

## Serie / Series / Serie

S

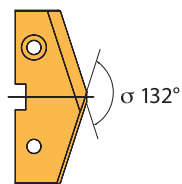

### Schneidplatten / Inserts / Inserti

1

Bezeichnung Designation Articolo	Durchmesser Diameter Diametro			beschichtet coated rivestito							unbeschichtet uncoated non rivestito		
	[mm]	[decimal]	[inch]	AK10 TiAlN	AK20 TiAlN	AP40 TiAlN	HSS TiN	HSS TiAlN	HSS 5 TiN	HSS 5 TiAlN	HSS 8 TiAlN	HSS 8 TiCN	AK 20
PS48	48,0	1,8898"						●		●			
PS49	49,0	1,9291"					●	●		●			
PS49.21	49,21	1,9375"	1 15/16				●	●					
PS50	50,0	1,9685"						●		●			
PS50.8	50,8	2,0000"	2							●			
PS51	51,0	2,0079"						●		●			
PS52	52,0	2,0472"	2 3/64					●		●			
PS52.5	52,5	2,0669"								●			
PS53	53,0	2,0866"						●		●			
PS53.98	53,98	2,1252"	2 1/8							●			
PS54	54,0	2,1260"						●		●			
PS55	55,0	2,1654"								●			
PS56	56,0	2,2047"					●	●		●			
PS57	57,0	2,2441"						●		●			
PS57.15	57,15	2,2500"	2 1/4							●			
PS58	58,0	2,2835"						●		●			
PS59	59,0	2,3228"								●			
PS60	60,0	2,3622"					●			●			
PS61	61,0	2,4016"								●			
PS62	62,0	2,4409"					●			●			
PS63	63,0	2,4803"						●		●			
PS63.50	63,5	2,5000"	2 1/2							●			
PS64	64,0	2,5197"					●			●			
PS65	65,0	2,5591"						●		●			
● Hauptanwendung Main Application Applicazione principale	P						●	●		●			
○ Nebenanwendung Secondary application Applicazione secondaria	M						○	○		●			
	K												
	N												
	S									○			
	H												

Hinweis: Zwischenabmessungen, die hier nicht aufgeführt sind, schleifen und beschichten wir Ihnen ab 5 Stück ohne Mehrpreis!

Remark: Other none standard diameters are available upon request.

Attenzione: Misure non indicate sono disponibili senza incremento prezzo per minimo 5pz.

## Serie / Series / Serie

**S**

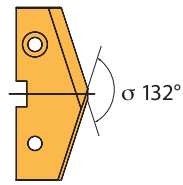

## Schneidplatten / Inserts / Inserti

### AS Geometrie / Geometry / Geometria

Bezeichnung Designation Articolo	Durchmesser Diameter Diametro			beschichtet coated rivestito							unbeschichtet uncoated non rivestito		
	[mm]	[decimal]	[inch]	AK10 TiAlN	AK20 TiAlN	AP40 TiAlN	HSS TiN	HSS TiAlN	HSS 5 TiN	HSS 5 TiAlN	HSS 8 TiAlN	HSS 8 TiCN	AK 20
PS60-AS	60,0	2,3622"						●					

"AS" geometry not available for the US market.

- **Hauptanwendung**  
Main Application  
Applicazione principale
- **Nebenanwendung**  
Secondary application  
Applicazione secondaria

P								●					
M								○					
K													
N													
S													
H													

**Hinweis: Zwischenabmessungen, die hier nicht aufgeführt sind, schleifen und beschichten wir Ihnen ab 5 Stück ohne Mehrpreis!**

Remark: Other none standard diameters are available upon request.

Attenzione: Misure non indicate sono disponibili senza incremento prezzo per minimo 5pz.



## Serie / Series / Serie

# U

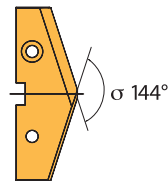

## Schneidplatten / Inserts / Inserti

# 1

Bezeichnung Designation Articolo	Durchmesser Diameter Diametro			beschichtet coated rivestito								unbeschichtet uncoated non rivestito	
	[mm]	[decimal]	[inch]	AK10 TiAlN	AK20 TiAlN	AP40 TiAlN	HSS TiN	HSS TiAlN	HSS 5 TiN	HSS 5 TiAlN	HSS 8 TiAlN	HSS 8 TiCN	AK 20
PU66	66,0	2,5984"								●			
PU66.68	66,68	2,6252"	2 5/8							●			
PU67	67,0	2,6378"						●		●			
PU67.47	67,47	2,6563"	2 21/32							●			
PU68	68,0	2,6772"						●		●			
PU69	69,0	2,7165"								●			
PU69.85	69,85	2,7500"	2 3/4							●			
PU70	70,0	2,7559"						●		●			
PU71	71,0	2,7953"								●			
PU71.44	71,44	2,8126"								●			
PU72	72,0	2,8346"						●		●			
PU73	73,0	2,8740"						●		●			
PU74	74,0	2,9134"						●		●			
PU75	75,0	2,9528"								●			
PU76	76,0	2,9921"						●		●			
PU76.2	76,2	3,0000"	3							●			
PU77	77,0	3,0315"								●			
PU77.78	77,78	3,0620"								●			
PU78	78,0	3,0709"					●	●		●			
PU79	79,0	3,1102"						●		●			
PU80	80,0	3,1496"						●		●			
PU81	81,0	3,1890"								●			
PU82	82,0	3,2283"								●			
PU82.55	82,55	3,2500"								●			
PU83	83,0	3,2677"								●			
PU84	84,0	3,3071"								●			
PU84.93	84,93	3,3437"	3 11/32							●			
PU85	85,0	3,3465"								●			
PU86	86,0	3,3858"								●			
PU87	87,0	3,4252"								●			
PU88	88,0	3,4646"								●			
PU88.9	88,9	3,5000"	3 1/2							●			
PU89	89,0	3,5039"								●			

● Hauptanwendung Main Application Applicazione principale	P	M	K	N	S	H
	●	●				
	○	○				
○ Nebenanwendung Secondary application Applicazione secondaria					○	

Hinweis: Zwischenabmessungen, die hier nicht aufgeführt sind, schleifen und beschichten wir Ihnen ab 5 Stück ohne Mehrpreis!

Remark: Other none standard diameters are available upon request.

Attenzione: Misure non indicate sono disponibili senza incremento prezzo per minimo 5pz.



## Serie / Series / Serie W

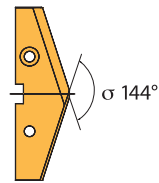

### Schneidplatten / Inserts / Inserti

Bezeichnung Designation Articolo	Durchmesser Diameter Diametro			beschichtet coated rivestito							unbeschichtet uncoated non rivestito		
	[mm]	[decimal]	[inch]	AK10 TiAlN	AK20 TiAlN	AP40 TiAlN	HSS TiN	HSS TiAlN	HSS 5 TiN	HSS 5 TiAlN	HSS 8 TiAlN	HSS 8 TiCN	AK 20
PW90	90,0	3,5433"						●		●			
PW91	91,0	3,5827"					●	●		●			
PW92	92,0	3,6221"						●		●			
PW93	93,0	3,6614"						●		●			
PW94	94,0	3,7008"						●		●			
PW95	95,0	3,7402"						●		●			
PW95.25	95,25	3,7500"								●			
PW96	96,0	3,7795"						●		●			
PW97	97,0	3,8189"						●		●			
PW98	98,0	3,8583"						●		●			
PW98.43	98,43	3,8725"	3 7/8							●			
PW99	99,0	3,8976"						●		●			
PW100	100,0	3,9370"	3 15/16					●		●			
PW101	101,0	3,9764"						●		●			
PW101.6	101,6	4,0000"	4							●			
PW102	102,0	4,0157"	4 1/64					●		●			
PW103	103,0	4,0551"						●		●			
PW104	104,0	4,0945"	4 3/32					●		●			
PW104.75	104,75	4,1240"	4 1/8							●			
PW105	105,0	4,1339"						●		●			
PW106	106,0	4,1732"						●		●			
PW107	107,0	4,2126"						●		●			
PW108	108,0	4,2520"						●		●			
PW109	109,0	4,2913"						●		●			
PW110	110,0	4,3307"						●		●			
PW111	111,0	4,3701"						●		●			
PW111.13	111,13	4,3752"					●			●			
PW112	112,0	4,4094"						●		●			
PW112.71	112,71	4,4374"	4 7/16							●			
PW113	113,0	4,4408"						●		●			
PW114	114,0	4,4882"						●		●			

● Hauptanwendung Main Application Applicazione principale	P		●	●		●							
	M		○	○		●							
○ Nebenanwendung Secondary application Applicazione secondaria	K												
	N												
	S									○			
	H												

Hinweis: Zwischenabmessungen, die hier nicht aufgeführt sind, schleifen und beschichten wir Ihnen ab 5 Stück ohne Mehrpreis!

Remark: Other none standard diameters are available upon request.

Attenzione: Misure non indicate sono disponibili senza incremento prezzo per minimo 5pz.



## Halter und Zubehör / Holder accessories / Accessori corpi

Bezeichnung Designation Articolo	Passend zu Haltern der Serien Used on the holder series Utilizzati sui corpi serie	❶ Schnellkupplung Fast action coupling Attacco rapido	❷ Kühlmitteladapter Rotary coolant adapters Anello refrigerante	❸ Stützstange Solid steady bar Barra anti rotazione
2KDA	A - C - E - G	SK-2KDA	R-2KDA	SS-2KDA
3KDA	I - K - M	SK-3KDA	R-3KDA	SS-3KDA
4KDA	O - Q	SK-4KDA	R-4KDA	SS-4KDA
5KDA	S	SK-5KDA	R-5KDA	SS-5KDA
6KDA	U - W	SK-6KDA	R-6KDA	SS-6KDA

## ❶ Schnellkupplung

Fast action coupling  
Attacco rapido

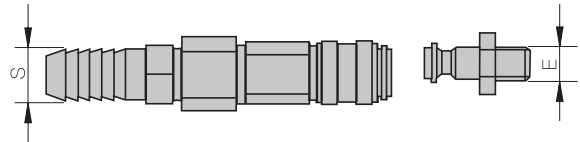

Bezeichnung Designation Articolo	Norm. Rohr-Gewinde E Norm pipe thread Filetto GAS	Schlauch- Ø S Hose Ø S Tubo Ø S
SK-2KDA	1/8"	9 mm
SK-3KDA	1/8"	9 mm
SK-4KDA	1/4"	9 mm
SK-5KDA	1/4"	12 mm
SK-6KDA	1/2"	12 mm

## ❷ Kühlmitteladapter

Rotary coolant adapter  
Anello refrigerante

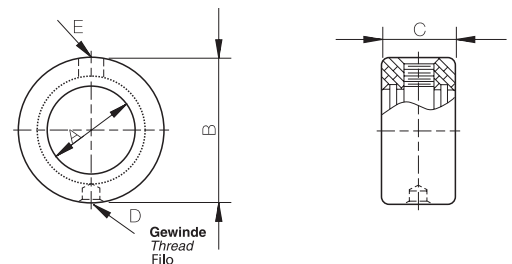

Bezeichnung Designation Articolo	A	B	C	D	E
R-2KDA	19,05	44,45	22,23	M8	1/8"
R-3KDA	25,40	53,97	28,57	M8	1/8"
R-4KDA	31,75	63,50	34,92	M10	1/4"
R-5KDA	44,45	76,20	34,92	M10	1/4"
R-6KDA	57,15	95,27	44,45	M12	1/2"

## ❸ Stützstange

Solid steady bar  
Barra anti rotazione

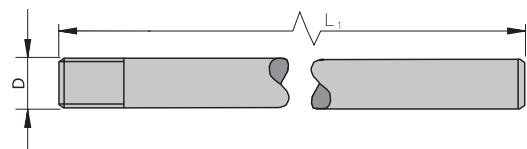

Bezeichnung Designation Articolo	Gewindegröße Thread size Filetto	L <sub>1</sub> [mm]
SS-2KDA	M8	250
SS-3KDA	M8	250
SS-4KDA	M10	250
SS-5KDA	M10	250
SS-6KDA	M12	250

## Schrauben und Schraubendreher / Screws and Screwdrivers / Chiavi e Viti

Bezeichnung Designation Articolo	für Ø-Bereich Drill Range used with Campo serie	Torx Schraubendreher Screwdriver Torx Chiave Torx	Anzugsmoment Torque Momento seraggio	Schrauben Screws Vite
A	9,5–11,0	T5107	0,6 Nm	AS 0011
C	11,5–12,8	T5107	0,6 Nm	AS 0011
E	13,0–17,5	T5108	1,3 Nm	AS 0012
G	15,5–17,5	T5108	1,3 Nm	AS 0018
I	17,8–24,0	T5109	2,2 Nm	AS 0013
K	22,0–24,0	T5109	2,2 Nm	AS 0019
M	24,5–35,0	T5115	5,1 Nm	AS 0014
O	30,0–35,0	T5115	5,1 Nm	AS 0014
Q	36,0–47,0	T5120	6,2 Nm	AS 0015
S	48,0–65,0	T5120	6,2 Nm	AS 0015
U	66,0–89,0	T5125	8,1 Nm	AS 0016
W	90,0–114,0	T5125	8,1 Nm	AS 0016

**Hinweis: Drehmoment-Schraubendreher siehe Seite 281.**

Remark: For torque screwdrivers see page 281.

Nota: Chiavi dinamometriche a pagina 281.



HSS-Einsätze

1

ISO	Werkstoff	Zugfestigkeit [N/mm²]	Schnittgeschwindigkeit V <sub>c</sub>										
			TiCN [m/min]	TiAlN [m/min]	Serie A, C 9,5 – 12,53 [mm/U]	Serie E, G 12,98 – 17,53 [mm/U]	Serie I, K 17,53 – 24,38 [mm/U]	Serie M, O 24,41 – 35,00 [mm/U]	Serie Q 35,00 – 47,8 [mm/U]	Serie S 47,85 – 65,00 [mm/U]	Serie U, W 66,00 – 114,48 [mm/U]		
P	Automatenstähle z. B. 9SMn28; 9SMnPb28; 10SPb20	bis 500	80	86	0,18	0,25	0,33	0,41	0,51	0,58	0,7		
		500 - 850	64	73	0,15	0,25	0,33	0,41	0,51	0,58	0,7		
	Baustähle z. B. St33; St37-2; St44-2; St52; St60	350 - 500	55	60	0,15	0,25	0,3	0,35	0,45	0,52	0,65		
		500 - 850	45	51	0,13	0,23	0,25	0,3	0,4	0,47	0,6		
	Unlegierte und niedrig legierter Stahl beinhaltet auch Vergütungsstähle und Einsatzstähle z. B. C15; C22; 20Mn5; Ck45	850 - 1200	40	43	0,1	0,2	0,23	0,25	0,35	0,43	0,5		
		bis 450	64	74	0,15	0,23	0,3	0,38	0,47	0,58	0,7		
		450 - 750	60	70	0,13	0,2	0,25	0,36	0,45	0,52	0,6		
		750 - 900	55	65	0,13	0,2	0,25	0,36	0,45	0,52	0,6		
	Legierter Stahl z. B. 42CrMo4; 16MnCr5; 36CrNiMo4 14NiCrMo13-4; Ck75; Ck101; 17CrNiMo8, 35CrMo4; 41Cr4; 50MnSi4	900 - 1100	51	60	0,1	0,18	0,23	0,3	0,4	0,47	0,55		
		bis 600	60	65	0,15	0,2	0,25	0,36	0,42	0,47	0,55		
		600 - 800	55	60	0,13	0,2	0,25	0,36	0,42	0,47	0,55		
		800 - 950	51	55	0,13	0,18	0,25	0,36	0,42	0,47	0,55		
950 - 110		47	51	0,1	0,15	0,23	0,3	0,37	0,42	0,5			
Hochlegierter und hochfester Stahl z. B. 41CrAlMo7; 36CrNiMo4; 32NiCrMo14-5	1100 - 1250	45	48	0,08	0,15	0,23	0,3	0,37	0,42	0,5			
	600 - 1000	30	35	0,13	0,18	0,23	0,25	0,35	0,42	0,5			
	1000 - 1200	25	27	0,1	0,13	0,23	0,25	0,35	0,42	0,5			
Werkzeugstähle z. B. C75W; 102Cr6; 105WCr6; X153CrMoV12	1200 - 1350	20	22	0,08	0,11	0,2	0,23	0,3	0,4	0,45			
	500 - 700	32	35	0,1	0,15	0,2	0,25	0,3	0,35	0,41			
M	Nichtrostender Stahl und Stahlguss	austenitisch und austenitisch/ferritisch, abgeschreckt	450 - 610	30	33	0,09	0,19	0,2	0,29	0,37	0,42	0,52	
		610 - 930	25	29	0,09	0,16	0,19	0,25	0,3	0,37	0,47		
K	Grauguss z. B. GG25; GG40	perlitisch, ferritisch	500 - 700	61	70	0,16	0,29	0,37	0,47	0,57	0,65	0,72	
		perlitisch, martensitisch	700 - 850	45	50	0,14	0,19	0,24	0,3	0,37	0,44	0,52	
	Gusseisen mit Kugelgraphit z. B. GGG50	850 - 1100	38	42	0,11	0,16	0,19	0,24	0,29	0,37	0,42		
		ferritisch	540	50	57	0,16	0,22	0,3	0,4	0,45	0,5	0,6	
Temperguss z. B. GTS70	perlitisch	850	45	50	0,13	0,17	0,22	0,28	0,35	0,45	0,5		
	ferritisch	450	50	57	0,16	0,22	0,3	0,4	0,45	0,5	0,6		
N	Aluminium-Knetlegierungen z. B. AlMgSiPb; AlCuMg1; AlMgSi1	ferritisch	450	50	57	0,16	0,22	0,3	0,4	0,45	0,5	0,6	
		perlitisch	780	45	50	0,13	0,17	0,22	0,28	0,35	0,45	0,5	
	Aluminium-Gusslegierungen z. B. G-AlSi10Mg; G-ALSi12	Aluminium-Knetlegierungen	nicht aushärtbar	200	210	250	0,12	0,17	0,28	0,34	0,56	0,65	0,65
		aushärtbar, ausgehärtet	335	125	140	0,2	0,34	0,4	0,45	0,57	0,65	0,65	
	≤ 12 % Si, ausgehärtet	250	200	240	0,2	0,33	0,41	0,48	0,56	0,64	0,64		
	≤ 12 % Si, aushärtbar, ausgehärtet	300	160	190	0,2	0,33	0,41	0,48	0,56	0,64	0,64		
Kupfer und Kupferlegierungen (Bronze / Messing)	Aluminiumbronze	≤ 12 % Si, nicht aushärtbar	450	140	160	0,18	0,3	0,38	0,45	0,56	0,64	0,64	
	Automatenlegierung, Pb > 1 % Messing, Rotguss	Kupfer und Elektrolytkupfer	370	102	117	0,18	0,3	0,4	0,5	0,6	0,7	0,75	
		300	123	138	0,19	0,3	0,42	0,52	0,62	0,72	0,76		
		500	68	77	0,16	0,29	0,37	0,47	0,57	0,67	0,72		
Nichtmetallische Werkstoffe	Duroplaste	200	46	51	0,06	0,09	0,16	0,21	0,26	0,36	0,41		
	Faserverstärkte Kunststoffe	Die Schnittwerte sind abhängig von der vorhandenen Kühlung. Startwerte wie bei Aluminium-Knetlegierungen (Luftkühlung ist empfohlen).											
	Hartgummi	Die Schnittwerte sind abhängig von der vorhandenen Kühlung. Startwerte wie bei Aluminium-Knetlegierungen (Luftkühlung ist empfohlen).											
S	Warmfeste Legierungen / Superlegierungen z. B. Inconell, Hasteloy, Nimonic, Waspaloy, Monel	Fe-Basis gegläht	700	12	13	0,08	0,17	0,21	0,25	0,3	0,35	0,35	
		Fe-Basis ausgehärtet	980	-	-	-	-	-	-	-	-	-	
		Ni- oder Co-Basis gegläht	850	12	13	0,08	0,17	0,21	0,25	0,3	0,35	0,35	
		Ni- oder Co-Basis gegossen	1100	-	-	-	-	-	-	-	-	-	
		ausgehärtet	1230	8	11	0,08	0,14	0,19	0,21	0,26	0,32	0,32	
Titanlegierungen z. B. Ti99,5; Ti Al6V4; TiCu2	Reintitan	500 - 700	13	15	0,09	0,19	0,21	0,25	0,31	0,37	0,4		
	700 - 1050	12	15	0,09	0,16	0,19	0,2	0,26	0,31	0,31			
H	Gehärteter Stahl	gehärtet und angelassen	1020 - 1365	22	30	0,09	0,16	0,2	0,24	0,3	0,42	0,47	
		gehärtet und angelassen	1365 - 1850	13	15	0,06	0,13	0,19	0,2	0,26	0,3	0,4	
	Hartguss	gegossen	1365	-	-	0,08	0,15	0,2	0,23	0,3	0,38	0,43	
Gehärtetes Gusseisen	gehärtet und angelassen	2090	-	-	-	-	-	-	-	-	-		

Bitte beachten Sie, dass die nachfolgend genannten Werte als Richtwerte gelten und sich auf die Kühlmittelbedingungen, wie sie auf Seite 99 im Katalog „Bohrsystem SHARK-Drill“ beschrieben werden, beziehen. Wichtig ist auch, dass maschinenseitige Rahmenbedingungen als durchschnittlich bewertet werden können. Zur technischen Unterstützung wenden Sie sich bitte an unser Kompetenz-Team.

HM-Einsätze

ISO	Werkstoff	Zugfestigkeit [N/mm²]	Schnittgeschwindigkeit V <sub>c</sub>		Serie A, C 9,5 – 12,53 [mm/U]	Serie E, G 12,98 – 17,53 [mm/U]	Serie I, K 17,53 – 24,38 [mm/U]	Serie M, O 24,41 – 35,00 [mm/U]	Serie Q 35,00 – 47,8 [mm/U]	
			TiCN [m/min]	TiAlN [m/min]						
P	Automatenstähle z. B. 9SMn28; 9SMnPb28; 10SPb20	bis 500	115	125	0,15	0,21	0,28	0,35	0,43	
		500 - 850	90	105	0,13	0,21	0,28	0,35	0,43	
	Baustähle z. B. St33; St37-2; St44-2; St52; St60	350 - 500	85	95	0,13	0,21	0,26	0,3	0,38	
		500 - 850	68	75	0,11	0,2	0,21	0,26	0,34	
	Unlegierte und niedrig legierter Stahl beinhaltet auch Vergütungsstähle und Einsatzstähle z. B. C15; C22; 20Mn5; Ck45	850 - 1200	62	70	0,09	0,17	0,2	0,21	0,3	
		bis 450	110	120	0,13	0,2	0,26	0,32	0,4	
		450 - 750	85	95	0,11	0,17	0,21	0,31	0,38	
		750 - 900	70	85	0,11	0,17	0,21	0,31	0,38	
	Legierter Stahl z. B. 42CrMo4; 16MnCr5; 36CrNiMo4 14NiCrMo13-4; Ck75; Ck101; 17CrNiMo8, 35CrMo4; 41Cr4; 50MnSi4	900 - 1100	60	70	0,09	0,15	0,2	0,26	0,34	
		bis 600	90	100	0,13	0,17	0,21	0,31	0,36	
		600 - 800	80	90	0,11	0,17	0,21	0,31	0,36	
		800 - 950	70	85	0,11	0,15	0,21	0,31	0,36	
Hochlegierter und hochfester Stahl z. B. 41CrAlMo7; 36CrNiMo4; 32NiCrMo14-5	950 - 110	67	75	0,09	0,13	0,2	0,26	0,31		
	1100 - 1250	60	65	0,07	0,13	0,2	0,26	0,31		
	600 - 1000	55	60	0,11	0,15	0,2	0,21	0,3		
Werkzeugstähle z. B. C75W; 102Cr6; 105WCr6; X153CrMoV12	1000 - 1200	50	55	0,09	0,11	0,2	0,21	0,3		
	1200 - 1350	44	50	0,07	0,09	0,17	0,2	0,26		
	500 - 700	60	65	0,09	0,13	0,17	0,21	0,26		
M	Nichtrostender Stahl und Stahlguss	austenitisch und austenitisch/ferritisch, abgeschreckt	700 - 950	45	50	0,09	0,13	0,17	0,21	0,26
		450 - 610	58	65	0,09	0,16	0,19	0,24	0,3	
K	Grauguss z. B. GG25; GG40	perlitisch, ferritisch	610 - 930	44	50	0,09	0,14	0,16	0,2	0,25
		perlitisch, martensitisch	500 - 700	103	123	0,14	0,2	0,26	0,37	0,45
	Gusseisen mit Kugelgraphit z. B. GGG50	ferritisch	700 - 850	80	95	0,1	0,16	0,19	0,26	0,37
		perlitisch	850 - 1100	70	84	0,1	0,14	0,16	0,22	0,32
Temperguss z. B. GTS70	ferritisch	450	105	125	0,12	0,17	0,2	0,29	0,4	
	perlitisch	780	78	97	0,1	0,14	0,18	0,26	0,37	
N	Aluminium-Knetlegierungen z. B. AlMgSiPb; AlCuMg1; AlMgSi1	nicht aushärtbar	200	410	450	0,1	0,17	0,27	0,33	0,38
		aushärtbar, ausgehärtet	335	275	305	0,12	0,29	0,37	0,52	0,6
	Aluminium-Gusslegierungen z. B. G-AlSi10Mg; G-ALSi12	≤ 12 % Si, ausgehärtet	250	400	450	0,2	0,31	0,4	0,48	0,5
		≤ 12 % Si, aushärtbar, ausgehärtet	300	350	380	0,2	0,3	0,4	0,48	0,5
		≤ 12 % Si, nicht aushärtbar	450	250	280	0,18	0,28	0,36	0,46	0,48
Kupfer und Kupferlegierungen (Bronze / Messing)	Automatenlegierung, Pb > 1 %	370	130	145	0,15	0,23	0,28	0,38	0,45	
	Messing, Rotguss	300	160	185	0,16	0,24	0,29	0,39	0,45	
	Aluminiumbronze	500	100	110	0,14	0,2	0,26	0,37	0,42	
	Kupfer und Elektrolytkupfer	200	100	120	0,05	0,09	0,1	0,16	0,25	
Nichtmetallische Werkstoffe	Duroplaste	Die Schnittwerte sind abhängig von der vorhandenen Kühlung. Startwerte wie bei Aluminium-Knetlegierungen (Luftkühlung ist empfohlen).								
	Faserverstärkte Kunststoffe									
	Hartgummi									
S	Warmfeste Legierungen / Superlegierungen z. B. Inconell, Hasteloy, Nimonic, Waspaloy, Monel	Fe-Basis gegläht	700	29	32	0,08	0,16	0,2	0,24	0,3
		Fe-Basis ausgehärtet	980	-	-	-	-	-	-	-
		Ni- oder Co-Basis gegläht	850	29	32	0,08	0,16	0,2	0,24	0,3
		Ni- oder Co-Basis gegossen ausgehärtet	1100	-	-	-	-	-	-	-
	Titanlegierungen z. B. Ti99,5; Ti Al6V4; TiCu2	1230	21	25	0,08	0,12	0,16	0,18	0,25	
H	Gehärteter Stahl	Reintitan	500 - 700	33	39	0,09	0,16	0,19	0,24	0,3
		gehärtet und angelassen	700 - 1050	29	34	0,09	0,14	0,16	0,22	0,28
	Hartguss	gehärtet und angelassen	1020 - 1365	40	44	0,09	0,14	0,22	0,25	0,32
		gegossen	1365 - 1850	24	26	0,06	0,11	0,16	0,22	0,27
Gehärtetes Gusseisen	gegossen	1365	30	35	0,07	0,12	0,18	0,22	0,27	
	Gehärtetes Gusseisen	gehärtet und angelassen	2090	-	-	-	-	-	-	

Bitte beachten Sie, dass die nachfolgend genannten Werte als Richtwerte gelten und sich auf die Kühlmittelbedingungen, wie sie auf Seite 99 im Katalog „Bohrsystem SHARK-Drill“ beschrieben werden, beziehen. Wichtig ist auch, dass maschinenseitige Rahmenbedingungen als durchschnittlich bewertet werden können. Zur technischen Unterstützung wenden Sie sich bitte an unser Kompetenz-Team.

Flachschneideinsätze

ISO	Werkstoff	Zugfestigkeit [N/mm <sup>2</sup> ]	Schnittgeschwindigkeit V <sub>c</sub>		Serie A, C 9,5 – 12,53 [mm/U]	Serie E, G 12,98 – 17,53 [mm/U]	Serie I, K 17,53 – 24,38 [mm/U]	Serie M, O 24,41 – 35,00 [mm/U]	Serie Q 35,00 – 47,8 [mm/U]	
			TiCN [m/min]	TiAlN [m/min]						
P	Automatenstähle z. B. 9SMn28; 9SMnPb28; 10SPb20	bis 500	–	69	0,14	0,2	0,26	0,33	0,41	
		500 - 850	–	58	0,12	0,2	0,26	0,33	0,41	
	Baustähle z. B. St33; St37-2; St44-2; St52; St60	350 - 500	–	48	0,12	0,2	0,24	0,28	0,36	
		500 - 850	–	41	0,1	0,18	0,2	0,24	0,32	
		850 - 1200	–	34	0,08	0,16	0,18	0,2	0,28	
	Unlegierte und niedrig legierter Stahl beinhaltet auch Vergütungsstähle und Einsatzstähle z. B. C15; C22; 20Mn5; Ck45	bis 450	–	59	0,12	0,18	0,24	0,3	0,38	
		450 - 750	–	56	0,1	0,16	0,2	0,29	0,36	
		750 - 900	–	52	0,1	0,16	0,2	0,29	0,36	
		900 - 1100	–	48	0,08	0,14	0,18	0,24	0,32	
	Legierter Stahl z. B. 42CrMo4; 16MnCr5; 36CrNiMo4 14NiCrMo13-4; Ck75; Ck101; 17CrNiMo8; 35CrMo4; 41Cr4; 50MnSi4	bis 600	–	52	0,12	0,16	0,2	0,29	0,34	
		600 - 800	–	48	0,1	0,16	0,2	0,29	0,34	
		800 - 950	–	44	0,1	0,14	0,2	0,29	0,34	
		950 - 110	–	41	0,08	0,12	0,18	0,24	0,3	
		1100 - 1250	–	38	0,06	0,12	0,18	0,24	0,3	
	Hochlegierter und hochfester Stahl z. B. 41CrAlMo7; 36CrNiMo4; 32NiCrMo14-5	600 - 1000	–	28	0,1	0,14	0,18	0,2	0,28	
1000 - 1200		–	22	0,08	0,1	0,18	0,2	0,28		
1200 - 1350		–	18	0,06	0,09	0,16	0,18	0,24		
Werkzeugstähle z. B. C75W; 102Cr6; 105WCr6; X153CrMoV12	500 - 700	–	28	0,08	0,12	0,16	0,2	0,24		
	700 - 950	–	22	0,08	0,12	0,16	0,2	0,24		
M	Nichtrostender Stahl und Stahlguss	austenitisch und austenitisch/ferritisch, abgeschreckt	450 - 610	–	26	0,14	0,19	0,2	0,25	0,29
		610 - 930	–	23	0,1	0,15	0,19	0,22	0,25	
K	Grauguss z. B. GG25; GG40	perlitisch, ferritisch	500 - 700	–	60	0,14	0,24	0,3	0,42	0,46
		perlitisch, martensitisch	700 - 850	–	47	0,1	0,15	0,2	0,25	0,3
	Gusseisen mit Kugelgraphit z. B. GGG50	ferritisch	540	–	58	0,14	0,24	0,29	0,4	0,45
		perlitisch	850	–	47	0,1	0,16	0,19	0,24	0,3
Temperguss z. B. GTS70	ferritisch	450	–	66	0,14	0,24	0,29	0,4	0,45	
	perlitisch	780	–	47	0,1	0,16	0,19	0,24	0,3	
N	Aluminium-Knetlegierungen z. B. AlMgSiPb; AlCuMg1; AlMgSi1	nicht aushärtbar	200	–	230	0,18	0,29	0,37	0,44	0,5
		aushärtbar, ausgehärtet	335	–	120	0,19	0,29	0,37	0,42	0,45
	Aluminium-Gusslegierungen z. B. G-AlSi10Mg; G-ALSi12	≤ 12 % Si, ausgehärtet	250	–	210	0,17	0,29	0,37	0,44	0,5
		≤ 12 % Si, aushärtbar, ausgehärtet	300	–	160	0,17	0,29	0,37	0,43	0,47
		≤ 12 % Si, nicht aushärtbar	450	–	120	0,17	0,29	0,37	0,42	0,45
	Kupfer und Kupferlegierungen (Bronze / Messing)	Automatenlegierung, Pb > 1 %	370	–	70	0,16	0,26	0,38	0,45	0,5
Messing, Rotguss		300	–	68	0,15	0,25	0,37	0,44	0,49	
Aluminiumbronze		500	–	60	0,14	0,24	0,3	0,42	0,45	
Kupfer und Elektrolytkupfer		200	–	45	0,06	0,09	0,16	0,2	0,3	
Nichtmetallische Werkstoffe	Duroplaste	Die Schnittwerte sind abhängig von der vorhandenen Kühlung. Startwerte wie bei Aluminium-Knetlegierungen (Luftkühlung ist empfohlen).								
	Faserverstärkte Kunststoffe									
	Hartgummi									
S	Warmfeste Legierungen / Superlegierungen z. B. Inconell, Hasteloy, Nimonic, Waspaloy, Monel	Fe-Basis gegläht	700	–	10	0,08	0,14	0,17	0,22	0,27
		Fe-Basis ausgehärtet	980	–	–	–	–	–	–	–
		Ni- oder Co-Basis gegläht	850	–	9	0,08	0,13	0,15	0,19	0,25
		Ni- oder Co-Basis gegossen ausgehärtet	1100	–	–	–	–	–	–	–
		1230	–	8	0,07	0,12	0,14	0,17	0,22	
Titanlegierungen z. B. Ti99,5; Ti Al6V4; TiCu2	Reintitan	500 - 700	–	15	0,09	0,15	0,19	0,24	0,25	
	700 - 1050	–	12	0,09	0,14	0,15	0,19	0,23		
H	Gehärteter Stahl	gehärtet und angelassen	1020 - 1365	–	20	0,09	0,14	0,19	0,2	0,24
		gehärtet und angelassen	1365 - 1850	–	13	0,09	0,1	0,15	0,19	0,2
	Hartguss	gegossen	1365	–	18	0,09	0,12	0,16	0,19	0,22
Gehärtetes Gusseisen	gehärtet und angelassen	2090	–	–	–	–	–	–	–	

Bitte beachten Sie, dass die nachfolgend genannten Werte als Richtwerte gelten und sich auf die Kühlmittelbedingungen, wie sie auf Seite 99 im Katalog „Bohrsystem SHARK-Drill“ beschrieben werden, beziehen. Wichtig ist auch, dass maschinenseitige Rahmenbedingungen als durchschnittlich bewertet werden können. Zur technischen Unterstützung wenden Sie sich bitte an unser Kompetenz-Team.

ISO	Werkstoff	Kühlmittel Druck [bar] Volumen [Liter/min]	HSS-Einsatz							HM-Einsatz				
			Serie A, C 9,5–12,95	Serie E, G 12,98–17,53	Serie I, K 17,53–24,38	Serie M, O 24,41–35,00	Serie Q 35,00–47,80	Serie S 47,85–65,00	Serie U, W 66,00–114,48	Serie A, C 9,5–12,95	Serie E, G 12,98–17,53	Serie I, K 17,53–24,38	Serie M, O 24,41–35,00	Serie Q 35,00–47,80
P	Automatenstähle	[bar] [Liter/min]	12 10	6 10	7 16	6 27	5 45	3 114	3 144	12 10	7 11	7 17	7 30	7 60
	Baustähle	[bar] [Liter/min]	11 9	6 10	6 16	5 23	5 45	3 114	3 144	12 10	7 11	6 16	6 27	5 47
	Unlegierte und niedrig legierter Stahl beinhaltet auch Vergütungsstähle und Einsatzstähle	[bar] [Liter/min]	11 9	4 11	4 12	2 19	2 30	2 87	2 98	11 9	4 10	4 12	4 19	3 40
	Legierter Stahl	[bar] [Liter/min]	12 9	6 10	5 14	4 23	4 38	2 98	2 117	15 11	10 13	10 22	9 34	7,5 56
	Hochlegierter und hochfester Stahl	[bar] [Liter/min]	11 9	5 8	4 12	2 20	2 30	2 87	2 98	15 11	5 12	4 13	4 20	3 40
	Werkzeugstähle	[bar] [Liter/min]	11 10	4 8	4 12	3 20	2 30	2 87	2 98	15 11	5 12	4 13	3 20	3 37
M	Nichtrostender Stahl und Stahlguss	[bar] [Liter/min]	12 10	6 10	5 14	4 23	4 38	2 98	2 117	15 11	10 13	10 22	9 34	9 70
K	Grauguss	[bar] [Liter/min]	11 9	5 9	4 13	3 19	2 34	2 98	2 106	11 9	5 9	5 12	5 19	4 49
	Gusseisen mit Kugelgraphit	[bar] [Liter/min]	11 9	5 9	4 13	3 19	2 34	2 98	2 106	11 9	5 9	5 12	5 19	4 49
	Temperguss	[bar] [Liter/min]	11 9	5 9	4 13	3 19	2 34	2 98	2 106	11 9	5 9	5 13	5 19	4 49
N	Aluminium-Knetlegierungen	[bar] [Liter/min]	15 10	12 14	16 23	11 34	9 61	4 125	4 159	22 13	19 17	19 28	17 45	14 77
	Aluminium-Gusslegierungen	[bar] [Liter/min]	15 10	12 14	16 23	11 34	9 61	4 125	4 159	22 13	19 17	19 28	17 45	14 77
	Kupfer und Kupferlegierungen (Bronze / Messing)	[bar] [Liter/min]	13 10	8 11	10 20	8 30	7 53	4 125	4 167	14 10	10 13	10 21	10 34	10 75
	Nichtmetallische Werkstoffe	[bar] [Liter/min]	Luftkühlung ist empfohlen.											
S	Wärmefeste Legierungen	[bar] [Liter/min]	11 9	4 11	4 12	2 19	2 30	2 87	2 98	18 10	11 11	10 12	10 19	9 62
	Titanlegierungen	[bar] [Liter/min]	11 9	5 9	4 12	2 19	2 30	2 98	2 125	18 10	11 11	10 16	10 27	9 62
H	Gehärteter Stahl	[bar] [Liter/min]	11 9	4 11	4 12	2 19	2 30	2 87	2 98	11 9	4 10	4 12	3 19	3 37
	Hartguss	[bar] [Liter/min]	11 9	4 11	4 12	2 19	2 30	2 87	2 98	11 9	4 10	4 12	3 19	3 37
	Gehärtetes Gusseisen	[bar] [Liter/min]	- -	- -	- -	- -	- -	- -	- -	- -	- -	- -	- -	- -

Diese Empfehlungen ermöglichen optimale Standzeiten und Spanabfuhr. Bei geringeren Werten müssen Verschleiß und Spanentwicklung beobachtet werden und gegebenenfalls die Schnittwerte angepasst werden.

Hinweis: Die Kühlmittelangaben gelten bis ca. 8xD Bohrtiefe.

Bei 8–12xD multiplizieren Sie die Werte mit 1,3. Bei 12–20xD mit 2,0. Über 20xD bitte mit 3,0 multiplizieren.



HSS inserts

1

ISO	Material	Tensile strength [N/mm <sup>2</sup> ]	Cutting speed V <sub>c</sub>		Series A, C 9.5-12.53 [mm/rev]	Series E, G 12.98-17.53 [mm/rev]	Series I, K 17.53-24.38 [mm/rev]	Series M, O 24.41-35.00 [mm/rev]	Series Q 35.00-47.8 [mm/rev]	Series S 47.85-65.00 [mm/rev]	Series U, W 66.00-114.48 [mm/rev]	
			TiCN [m/min]	TiAlN [m/min]								
P	Unalloyed steel and cast steel e. G. 9SMn28; 9SMnPb28; 10SPb20	up to 500	80	86	0.18	0.25	0.33	0.41	0.51	0.58	0.7	
		500 - 850	64	73	0.15	0.25	0.33	0.41	0.51	0.58	0.7	
	Structural steel e. G. St33; St37-2; St44-2; St52; St60	350 - 500	55	60	0.15	0.25	0.3	0.35	0.45	0.52	0.65	
		500 - 850	45	51	0.13	0.23	0.25	0.3	0.4	0.47	0.6	
	None- and low alloy steel as well as carbon steel and case hardened steel e. G. C15; C22; 20Mn5; Ck45	850 - 1200	40	43	0.1	0.2	0.23	0.25	0.35	0.43	0.5	
		bis 450	64	74	0.15	0.23	0.3	0.38	0.47	0.58	0.7	
		450 - 750	60	70	0.13	0.2	0.25	0.36	0.45	0.52	0.6	
		750 - 900	55	65	0.13	0.2	0.25	0.36	0.45	0.52	0.6	
	Alloys steel e. G. 42CrMo4; 16MnCr5; 36CrNiMo4 14NiCrMo13-4; Ck75; Ck101; 17CrNiMo8; 35CrMo4; 41Cr4; 50MnSi4	900 - 1100	51	60	0.1	0.18	0.23	0.3	0.4	0.47	0.55	
		bis 600	60	65	0.15	0.2	0.25	0.36	0.42	0.47	0.55	
		600 - 800	55	60	0.13	0.2	0.25	0.36	0.42	0.47	0.55	
		800 - 950	51	55	0.13	0.18	0.25	0.36	0.42	0.47	0.55	
950 - 110		47	51	0.1	0.15	0.23	0.3	0.37	0.42	0.5		
High alloys steel e. G. 41CrAlMo7; 36CrNiMo4; 32NiCrMo14-5	1100 - 1250	45	48	0.08	0.15	0.23	0.3	0.37	0.42	0.5		
	600 - 1000	30	35	0.13	0.18	0.23	0.25	0.35	0.42	0.5		
	1000 - 1200	25	27	0.1	0.13	0.23	0.25	0.35	0.42	0.5		
Tool steel e. G. C75W; 102Cr6; 105WCr6; X153CrMoV12	1200 - 1350	20	22	0.08	0.11	0.2	0.23	0.3	0.4	0.45		
	500 - 700	32	35	0.1	0.15	0.2	0.25	0.3	0.35	0.41		
M	Stainless steel and cast steel	austenitic and austenitic/ferritic	450 - 610	30	33	0.09	0.19	0.2	0.29	0.37	0.42	0.52
		chilled	610 - 930	25	29	0.09	0.16	0.19	0.25	0.3	0.37	0.47
K	Cast iron e. G. GG25; GG40	pearlitic, ferritic	500 - 700	61	70	0.16	0.29	0.37	0.47	0.57	0.65	0.72
		pearlitic, martensitic	700 - 850	45	50	0.14	0.19	0.24	0.3	0.37	0.44	0.52
	Cast iron with nodular graphite e. G. GGG50	ferritic	540	50	57	0.16	0.22	0.3	0.4	0.45	0.5	0.6
		pearlitic	850	45	50	0.13	0.17	0.22	0.28	0.35	0.45	0.5
Malleable cast iron e. G. GTS70	ferritic	450	50	57	0.16	0.22	0.3	0.4	0.45	0.5	0.6	
	pearlitic	780	45	50	0.13	0.17	0.22	0.28	0.35	0.45	0.5	
N	Aluminium alloys, long chipping e. G. AlMgSiPb; AlCuMg1; AMgSi1	not heat treatable	200	210	250	0.12	0.17	0.28	0.34	0.56	0.65	0.65
		heat treatable, heat-treated	335	125	140	0.2	0.34	0.4	0.45	0.57	0.65	0.65
	Casted aluminium alloys e. G. G-AlSi10Mg; G-ALSi12	≤ 12 % Si, hardened	250	200	240	0.2	0.33	0.41	0.48	0.56	0.64	0.64
		≤ 12 % Si, heat treatable, hardened	300	160	190	0.2	0.33	0.41	0.48	0.56	0.64	0.64
		≤ 12 % Si, not heat treatable	450	140	160	0.18	0.3	0.38	0.45	0.56	0.64	0.64
	Copper and copper alloys (brass / bronze)	Lead alloys, Pb > 1 %	370	102	117	0.18	0.3	0.4	0.5	0.6	0.7	0.75
Brass, bronze		300	123	138	0.19	0.3	0.42	0.52	0.62	0.72	0.76	
Aluminium bronze		500	68	77	0.16	0.29	0.37	0.47	0.57	0.67	0.72	
Copper and electrolyte copper		200	46	51	0.06	0.09	0.16	0.21	0.26	0.36	0.41	
Non-ferrous materials	Duroplastics	The cutting datas are depending on the available coolant supply. Starting datas are the same as aluminium alloys, long chipping. Air coolant is recommended.										
	Re- inforced plastics											
	Hard rubber											
S	High temperature resistant alloys e. G. Inconell, Hasteloy, Nimonic, Waspaloy, Monel	Fe-alloyed annealed	700	12	13	0.08	0.17	0.21	0.25	0.3	0.35	0.35
		heat - treated	980	-	-	-	-	-	-	-	-	-
		Ni- or annealed	850	12	13	0.08	0.17	0.21	0.25	0.3	0.35	0.35
		Co based casting	1100	-	-	-	-	-	-	-	-	-
		heat - treated	1230	8	11	0.08	0.14	0.19	0.21	0.26	0.32	0.32
Titanium alloys / Titan e. G. Ti99,5; Ti Al6V4; TiCu2	Pure titan	500 - 700	13	15	0.09	0.19	0.21	0.25	0.31	0.37	0.4	
		700 - 1050	12	15	0.09	0.16	0.19	0.2	0.26	0.31	0.31	
H	Hardened steel	hardened and tempered	1020 - 1365	22	30	0.09	0.16	0.2	0.24	0.3	0.42	0.47
		hardened and tempered	1365 - 1850	13	15	0.06	0.13	0.19	0.2	0.26	0.3	0.4
	Hard cast iron	casting	1365	-	-	0.08	0.15	0.2	0.23	0.3	0.38	0.43
Hardened cast iron	hardened and tempered	2090	-	-	-	-	-	-	-	-	-	

Please note that the recommended cutting datas are a starting reference point in combination with the coolant figures on page 103 in the catalogue "Drillsystem SHARK-Drill®". Also important is that the basic conditions are on an average. For technical support please contact our application engineers.



Carbide inserts

ISO	Material	Tensile strength [N/mm <sup>2</sup> ]	Cutting speed V <sub>c</sub>		Serie A, C 9.5 – 12.53 [mm/rev]	Serie E, G 12.98 – 17.53 [mm/rev]	Serie I, K 17.53 – 24.38 [mm/rev]	Serie M, O 24.41 – 35.00 [mm/rev]	Serie Q 35.00 – 47.8 [mm/rev]	
			TiCN [m/min]	TiAlN [m/min]						
P	Unalloyed steel and cast steel e. G. 9SMn28; 9SMnPb28; 10SPb20	up to 500	115	125	0.15	0.21	0.28	0.35	0.43	
		500 - 850	90	105	0.13	0.21	0.28	0.35	0.43	
	Structural steel e. G. St33; St37-2; St44-2; St52; St60	350 - 500	85	95	0.13	0.21	0.26	0.3	0.38	
		500 - 850	68	75	0.11	0.2	0.21	0.26	0.34	
	None- and low alloy steel as well as carbon steel and case hardened steel e. G. C15; C22; 20Mn5; Ck45	850 - 1200	62	70	0.09	0.17	0.2	0.21	0.3	
		bis 450	110	120	0.13	0.2	0.26	0.32	0.4	
		450 - 750	85	95	0.11	0.17	0.21	0.31	0.38	
		750 - 900	70	85	0.11	0.17	0.21	0.31	0.38	
	Alloys steel e. G. 42CrMo4; 16MnCr5; 36CrNiMo4 14NiCrMo13-4; Ck75; Ck101; 17CrNiMo8; 35CrMo4; 41Cr4; 50MnSi4	900 - 1100	60	70	0.09	0.15	0.2	0.26	0.34	
		bis 600	90	100	0.13	0.17	0.21	0.31	0.36	
		600 - 800	80	90	0.11	0.17	0.21	0.31	0.36	
		800 - 950	70	85	0.11	0.15	0.21	0.31	0.36	
950 - 110		67	75	0.09	0.13	0.2	0.26	0.31		
High alloys steel e. G. 41CrAlMo7; 36CrNiMo4; 32NiCrMo14-5	1100 - 1250	60	65	0.07	0.13	0.2	0.26	0.31		
	600 - 1000	55	60	0.11	0.15	0.2	0.21	0.3		
	1000 - 1200	50	55	0.09	0.11	0.2	0.21	0.3		
Tool steel e. G. C75W; 102Cr6; 105WCr6; X153CrMoV12	1200 - 1350	44	50	0.07	0.09	0.17	0.2	0.26		
	500 - 700	60	65	0.09	0.13	0.17	0.21	0.26		
M	Stainless steel and cast steel	austenitic and austenitic/ferritic	500 - 700	60	65	0.09	0.13	0.17	0.21	0.26
		chilled	700 - 950	45	50	0.09	0.13	0.17	0.21	0.26
K	Cast iron e. G. GG25; GG40	pearlitic, ferritic	450 - 610	58	65	0.09	0.16	0.19	0.24	0.3
		pearlitic, martensitic	610 - 930	44	50	0.09	0.14	0.16	0.2	0.25
	Cast iron with nodular graphite e. G. GGG50	ferritic	500 - 700	103	123	0.14	0.2	0.26	0.37	0.45
		pearlitic	700 - 850	80	95	0.1	0.16	0.19	0.26	0.37
Malleable cast iron e. G. GTS70	ferritic	850 - 1100	70	84	0.1	0.14	0.16	0.22	0.32	
	pearlitic	540	100	120	0.12	0.17	0.2	0.29	0.45	
N	Aluminium alloys, long chipping e. G. AlMgSiPb; AlCuMg1; AlMgSi1	not heat treatable	850	75	95	0.1	0.14	0.18	0.26	0.37
		heat treatable, heat-treated	450	105	125	0.12	0.17	0.2	0.29	0.4
	Casted aluminium alloys e. G. G-ALSi10Mg; G-ALSi12	≤ 12 % Si, hardened	780	78	97	0.1	0.14	0.18	0.26	0.37
		≤ 12 % Si, heat treatable, hardened	200	410	450	0.1	0.17	0.27	0.33	0.38
		≤ 12 % Si, not heat treatable	335	275	305	0.12	0.29	0.37	0.52	0.6
	Copper and copper alloys (brass / bronze)	Lead alloys, Pb > 1 %	250	400	450	0.2	0.31	0.4	0.48	0.5
		Brass, bronze	300	350	380	0.2	0.3	0.4	0.48	0.5
		Aluminium bronze	450	250	280	0.18	0.28	0.36	0.46	0.48
Copper and electrolyte copper		370	130	145	0.15	0.23	0.28	0.38	0.45	
Non-ferrous materials	Duroplastics	300	160	185	0.16	0.24	0.29	0.39	0.45	
	Re- inforced plastics	500	100	110	0.14	0.2	0.26	0.37	0.42	
	Hard rubber	200	100	120	0.05	0.09	0.1	0.16	0.25	
S	High temperature resistant alloys e. G. Inconell, Hasteloy, Nimonic, Waspaloy, Monel	Fe-alloyed annealed	The cutting datas are depending on the available coolant supply. Starting datas are the same as aluminium alloys, long chipping. Air coolant is recommended.							
		heat - treated								
		Ni- or annealed								
		Co based casting								
	heat - treated									
Titanium alloys / Titan e. G. Ti99,5; Ti Al6V4; TiCu2	Pure titan	700	29	32	0.08	0.16	0.2	0.24	0.3	
H	Hardened steel	700 - 1365	40	44	0.09	0.14	0.22	0.25	0.32	
		1365 - 1850	24	26	0.06	0.11	0.16	0.22	0.27	
	Hard cast iron	casting	1100	-	-	-	-	-	-	
	Hardened cast iron	hardened and tempered	1230	21	25	0.08	0.12	0.16	0.18	0.25

Please note that the recommended cutting datas are a starting reference point in combination with the coolant figures on page 103 in the catalogue "Drillsystem SHARK-Drill®". Also important is that the basic conditions are on an average. For technical support please contact our application engineers.

Flat bottom inserts

ISO	Material	Tensile strength [N/mm <sup>2</sup> ]	Cutting speed V <sub>c</sub>		Serie A, C 9.5 – 12.53 [mm/rev]	Serie E, G 12.98 – 17.53 [mm/rev]	Serie I, K 17.53 – 24.38 [mm/rev]	Serie M, O 24.41 – 35.00 [mm/rev]	Serie Q 35.00 – 47.8 [mm/rev]
			TiCN [m/min]	TiAlN [m/min]					
P	Unalloyed steel and cast steel e. G. 9SMn28; 9SMnPb28; 10SPb20	up to 500	–	69	0.14	0.2	0.26	0.33	0.41
		500 - 850	–	58	0.12	0.2	0.26	0.33	0.41
	Structural steel e. G. St33; St37-2; St44-2; St52; St60	350 - 500	–	48	0.12	0.2	0.24	0.28	0.36
		500 - 850	–	41	0.1	0.18	0.2	0.24	0.32
	None- and low alloy steel as well as carbon steel and case hardened steel e. G. C15; C22; 20Mn5; Ck45	850 - 1200	–	34	0.08	0.16	0.18	0.2	0.28
		bis 450	–	59	0.12	0.18	0.24	0.3	0.38
		450 - 750	–	56	0.1	0.16	0.2	0.29	0.36
	Alloys steel e. G. 42CrMo4; 16MnCr5; 36CrNiMo4 14NiCrMo13-4; Ck75; Ck101; 17CrNiMo8; 35CrMo4; 41Cr4; 50MnSi4	750 - 900	–	52	0.1	0.16	0.2	0.29	0.36
		900 - 1100	–	48	0.08	0.14	0.18	0.24	0.32
		bis 600	–	52	0.12	0.16	0.2	0.29	0.34
		600 - 800	–	48	0.1	0.16	0.2	0.29	0.34
		800 - 950	–	44	0.1	0.14	0.2	0.29	0.34
High alloys steel e. G. 41CrAlMo7; 36CrNiMo4; 32NiCrMo14-5	950 - 110	–	41	0.08	0.12	0.18	0.24	0.3	
	1100 - 1250	–	38	0.06	0.12	0.18	0.24	0.3	
	600 - 1000	–	28	0.1	0.14	0.18	0.2	0.28	
Tool steel e. G. C75W; 102Cr6; 105WCr6; X153CrMoV12	1000 - 1200	–	22	0.08	0.1	0.18	0.2	0.28	
	1200 - 1350	–	18	0.06	0.09	0.16	0.18	0.24	
M	Stainless steel and cast steel	austenitic and austenitic/ferritic	500 - 700	–	28	0.08	0.12	0.16	0.2
		chilled	700 - 950	–	22	0.08	0.12	0.16	0.2
K	Cast iron e. G. GG25; GG40	pearlitic, ferritic	450 - 610	–	26	0.14	0.19	0.2	0.25
		pearlitic, martensitic	610 - 930	–	23	0.1	0.15	0.19	0.22
	Cast iron with nodular graphite e. G. GGG50	ferritic	500 - 700	–	60	0.14	0.24	0.3	0.42
		pearlitic	700 - 850	–	47	0.1	0.15	0.2	0.25
Malleable cast iron e. G. GTS70	ferritic	850 - 1100	–	38	0.1	0.12	0.15	0.2	
	pearlitic	540	–	58	0.14	0.24	0.29	0.4	
N	Aluminium alloys, long chipping e. G. AlMgSiPb; AlCuMg1; AlMgSi1	not heat treatable	850	–	47	0.1	0.16	0.19	0.24
		heat treatable, heat-treated	450	–	66	0.14	0.24	0.29	0.4
	Casted aluminium alloys e. G. G-ALSi10Mg; G-ALSi12	≤ 12 % Si, hardened	780	–	47	0.1	0.16	0.19	0.24
		≤ 12 % Si, heat treatable, hardened	200	–	230	0.18	0.29	0.37	0.44
		≤ 12 % Si, not heat treatable	335	–	120	0.19	0.29	0.37	0.42
	Copper and copper alloys (brass / bronze)	Lead alloys, Pb > 1 %	250	–	210	0.17	0.29	0.37	0.44
		Brass, bronze	300	–	160	0.17	0.29	0.37	0.43
		Aluminium bronze	450	–	120	0.17	0.29	0.37	0.42
		Copper and electrolyte copper	370	–	70	0.16	0.26	0.38	0.45
	Non-ferrous materials	Duroplastics	300	–	68	0.15	0.25	0.37	0.44
Re- inforced plastics		500	–	60	0.14	0.24	0.3	0.42	
Hard rubber		200	–	45	0.06	0.09	0.16	0.2	
S	High temperature resistant alloys e. G. Inconell, Hasteloy, Nimonic, Waspaloy, Monel	Fe-alloyed annealed	700	–	10	0.08	0.14	0.17	0.22
		heat - treated	980	–	–	–	–	–	–
		Ni- or annealed	850	–	9	0.08	0.13	0.15	0.19
		Co based casting	1100	–	–	–	–	–	–
	Titanium alloys / Titan e. G. Ti99,5; Ti Al6V4; TiCu2	heat - treated	1230	–	8	0.07	0.12	0.14	0.17
H	Hardened steel	Pure titan	500 - 700	–	15	0.09	0.15	0.19	0.24
		700 - 1050	–	12	0.09	0.14	0.15	0.19	
	Hard cast iron	hardened and tempered	1020 - 1365	–	20	0.09	0.14	0.19	0.2
		hardened and tempered	1365 - 1850	–	13	0.09	0.1	0.15	0.19
Hardened cast iron	casting	1365	–	18	0.09	0.12	0.16	0.19	
	hardened and tempered	2090	–	–	–	–	–	–	

Please note that the recommended cutting datas are a starting reference point in combination with the coolant figures on page 103 in the catalogue "Drillsystem SHARK-Drill®". Also important is that the basic conditions are on an average. For technical support please contact our application engineers.

ISO	Material	Coolant pressure [bar] flow rate [litre/min]	HSS inserts							HM inserts				
			Series A, C 9.5–12.95	Series E, G 12.98–17.53	Series I, K 17.53–24.38	Series M, O 24.41–35.00	Series Q 35.00–47.80	Series S 47.85–65.00	Series U, W 66.00–114.48	Series A, C 9.5–12.95	Series E, G 12.98–17.53	Series I, K 17.53–24.38	Series M, O 24.41–35.00	Series Q 35.00–47.80
P	Unalloyed steel and cast steel	[bar]	12	6	7	6	5	3	3	12	7	7	7	7
		[litre/min]	10	10	16	27	45	114	144	10	11	17	30	60
	Structural steel	[bar]	11	6	6	5	5	3	3	12	7	6	6	5
		[litre/min]	9	10	16	23	45	114	144	10	11	16	27	47
	None- and low alloy steel as well as carbon steel and case hardened steel	[bar]	11	4	4	2	2	2	2	11	4	4	4	3
		[litre/min]	9	11	12	19	30	87	98	9	10	12	19	40
Alloys steel	[bar]	12	6	5	4	4	2	2	15	10	10	9	7.5	
	[litre/min]	9	10	14	23	38	98	117	11	13	22	34	56	
High alloys steel	[bar]	11	5	4	2	2	2	2	15	5	4	4	3	
	[litre/min]	9	8	12	20	30	87	98	11	12	13	20	40	
Tool steel	[bar]	11	4	4	3	2	2	2	15	5	4	3	3	
	[litre/min]	10	8	12	20	30	87	98	11	12	13	20	37	
M	Stainless steel and cast steel	[bar]	12	6	5	4	4	2	2	15	10	10	9	9
		[litre/min]	10	10	14	23	38	98	117	11	13	22	34	70
K	Cast iron	[bar]	11	5	4	3	2	2	2	11	5	5	5	4
		[litre/min]	9	9	13	19	34	98	106	9	9	12	19	49
	Cast iron with nodular graphite	[bar]	11	5	4	3	2	2	2	11	5	5	5	4
[litre/min]		9	9	13	19	34	98	106	9	9	12	19	49	
Malleable cast iron	[bar]	11	5	4	3	2	2	2	11	5	5	5	4	
	[litre/min]	9	9	13	19	34	98	106	9	9	13	19	49	
N	Aluminium alloys, long chipping	[bar]	15	12	16	11	9	4	4	22	19	19	17	14
		[litre/min]	10	14	23	34	61	125	159	13	17	28	45	77
	Casted aluminium alloys	[bar]	15	12	16	11	9	4	4	22	19	19	17	14
		[litre/min]	10	14	23	34	61	125	159	13	17	28	45	77
	Copper and copper alloys (brass / bronze)	[bar]	13	8	10	8	7	4	4	14	10	10	10	10
[litre/min]		10	11	20	30	53	125	167	10	13	21	34	75	
Non-ferrous materials	[bar] [litre/min]	Air coolant is recommended.												
S	High temperature resistant alloys	[bar]	11	4	4	2	2	2	2	18	11	10	10	9
		[litre/min]	9	11	12	19	30	87	98	10	11	12	19	62
Titanium alloys / Titan	[bar]	11	5	4	2	2	2	2	18	11	10	10	9	
	[litre/min]	9	9	12	19	30	98	125	10	11	16	27	62	
H	Hardened steel	[bar]	11	4	4	2	2	2	2	11	4	4	3	3
		[litre/min]	9	11	12	19	30	87	98	9	10	12	19	37
	Hard cast iron	[bar]	11	4	4	2	2	2	2	11	4	4	3	3
		[litre/min]	9	11	12	19	30	87	98	9	10	12	19	37
Hardened cast iron	[bar] [litre/min]	-	-	-	-	-	-	-	-	-	-	-	-	

These recommendations produce optimum tool life and chip evacuation. With lower values, wear and chip evacuation should receive attention. If necessary the speeds and feeds must be reduced.

Information: Please note that the coolant figures are recommendations for a drilling depth to 8xD. With longer drills multiply the recommended data as follows; 8 to 12xD multiply by 1.3; 12 to 20xD multiply by 2.0; over 20xD multiply by 3.0

Inserti HSS

ISO	Materiale	Carico di rottura [N/mm²]	Velocità di taglio V <sub>c</sub>		Serie A, C 9,5 - 12,53 [mm/giro]	Serie E, G 12,98 - 17,53 [mm/giro]	Serie I, K 17,53 - 24,38 [mm/giro]	Serie M, O 24,41 - 35,00 [mm/giro]	Serie Q 35,00 - 47,8 [mm/giro]	Serie S 47,85 - 65,00 [mm/giro]	Serie U, W 66,00 - 114,48 [mm/giro]	
			TICN [m/min]	TIAlN [m/min]								
P	Acciaio non legato o da fusione p. e. 9SMn28; 9SMnPb28; 10SPb20	fino a 500	80	86	0,18	0,25	0,33	0,41	0,51	0,58	0,7	
		500 - 850	64	73	0,15	0,25	0,33	0,41	0,51	0,58	0,7	
	Acciaio da costruzione p. e. St33; St37-2; St44-2; St52; St60	350 - 500	55	60	0,15	0,25	0,3	0,35	0,45	0,52	0,65	
		500 - 850	45	51	0,13	0,23	0,25	0,3	0,4	0,47	0,6	
	Acciaio non legato o debolmente legato, acciaio al carbonio o acciaio stampato p. e. C15; C22; 20Mn5; Ck45	850 - 1200	40	43	0,1	0,2	0,23	0,25	0,35	0,43	0,5	
		bis 450	64	74	0,15	0,23	0,3	0,38	0,47	0,58	0,7	
		450 - 750	60	70	0,13	0,2	0,25	0,36	0,45	0,52	0,6	
		750 - 900	55	65	0,13	0,2	0,25	0,36	0,45	0,52	0,6	
	Acciaio legato p. e. 42CrMo4; 16MnCr5; 36CrNiMo4 14NiCrMo13-4; Ck75; Ck101; 17CrNiMo8, 35CrMo4; 41Cr4; 50MnSi4	900 - 1100	51	60	0,1	0,18	0,23	0,3	0,4	0,47	0,55	
		bis 600	60	65	0,15	0,2	0,25	0,36	0,42	0,47	0,55	
		600 - 800	55	60	0,13	0,2	0,25	0,36	0,42	0,47	0,55	
		800 - 950	51	55	0,13	0,18	0,25	0,36	0,42	0,47	0,55	
950 - 110		47	51	0,1	0,15	0,23	0,3	0,37	0,42	0,5		
Acciaio fortemente legato p. e. 41CrAlMo7; 36CrNiMo4; 32NiCrMo14-5	1100 - 1250	45	48	0,08	0,15	0,23	0,3	0,37	0,42	0,5		
	600 - 1000	30	35	0,13	0,18	0,23	0,25	0,35	0,42	0,5		
	1000 - 1200	25	27	0,1	0,13	0,23	0,25	0,35	0,42	0,5		
Acciaio da utensili p. e. C75W; 102Cr6; 105WCr6; X153CrMoV12	1200 - 1350	20	22	0,08	0,11	0,2	0,23	0,3	0,4	0,45		
	500 - 700	32	35	0,1	0,15	0,2	0,25	0,3	0,35	0,41		
M	Acciaio inossidabile ed acciaio da fusione	austenitico e austenitico/ferritico	450 - 610	30	33	0,09	0,19	0,2	0,29	0,37	0,42	0,52
		temprato	610 - 930	25	29	0,09	0,16	0,19	0,25	0,3	0,37	0,47
K	Ghisa p. e. GG25; GG40	perlitica, ferritica	500 - 700	61	70	0,16	0,29	0,37	0,47	0,57	0,65	0,72
		perlitica, martensitica	700 - 850	45	50	0,14	0,19	0,24	0,3	0,37	0,44	0,52
	Ghisa grigia sferoidale p. e. GGG50	ferritica	540	50	57	0,16	0,22	0,3	0,4	0,45	0,5	0,6
		perlitica	850	45	50	0,13	0,17	0,22	0,28	0,35	0,45	0,5
Ghisa malleabile p. e. GTS70	ferritica	450	50	57	0,16	0,22	0,3	0,4	0,45	0,5	0,6	
	perlitica	780	45	50	0,13	0,17	0,22	0,28	0,35	0,45	0,5	
N	Leghe di Alluminio a truciolo lungo p. e. AlMgSiPb; AlCuMg1; AlMgSi1	non temprabile	200	210	250	0,12	0,17	0,28	0,34	0,56	0,65	0,65
		temprabile, temprato	335	125	140	0,2	0,34	0,4	0,45	0,57	0,65	0,65
	Leghe di Alluminio da getti p. e. G-ALSi10Mg; G-ALSi12	≤ 12 % Si, temprato	250	200	240	0,2	0,33	0,41	0,48	0,56	0,64	0,64
		≤ 12 % Si, temprabile, temprato	300	160	190	0,2	0,33	0,41	0,48	0,56	0,64	0,64
		≤ 12 % Si, non temprabile	450	140	160	0,18	0,3	0,38	0,45	0,56	0,64	0,64
	Rame e leghe di rame (ottone / bronzo)	Legate al piombo, Pb > 1 %	370	102	117	0,18	0,3	0,4	0,5	0,6	0,7	0,75
		Ottone / Bronzo	300	123	138	0,19	0,3	0,42	0,52	0,62	0,72	0,76
		Bronzo alluminio	500	68	77	0,16	0,29	0,37	0,47	0,57	0,67	0,72
		Rame e rame elettrolitico	200	46	51	0,06	0,09	0,16	0,21	0,26	0,36	0,41
	Materiali non ferrosi	Plastiche dure	I parametri di taglio dipendono dalla quantità di refrigerante disponibile. Come parametri di partenza utilizzare dati per leghe di alluminio a truciolo lungo.									
		Plastiche rinforzate										
		Gomme dure										
S	Leghe esotiche resistenti alle alte temperature p. e. Inconell, Hasteloy, Nimonic, Waspaloy, Monel	Fe-legate ricotto	700	12	13	0,08	0,17	0,21	0,25	0,3	0,35	0,35
		temprato	980	-	-	-	-	-	-	-	-	-
		Ni o ricotto	850	12	13	0,08	0,17	0,21	0,25	0,3	0,35	0,35
		Co legato stampato	1100	-	-	-	-	-	-	-	-	-
		temprato	1230	8	11	0,08	0,14	0,19	0,21	0,26	0,32	0,32
Leghe di titanio, Titanio p. e. Ti99,5; Ti Al6V4; TiCu2	Titanio puro	500 - 700	13	15	0,09	0,19	0,21	0,25	0,31	0,37	0,4	
		700 - 1050	12	15	0,09	0,16	0,19	0,2	0,26	0,31	0,31	
H	Acciaio temprato	temprato	1020 - 1365	22	30	0,09	0,16	0,2	0,24	0,3	0,42	0,47
		temprato	1365 - 1850	13	15	0,06	0,13	0,19	0,2	0,26	0,3	0,4
	Ghisa temprata	stampato	1365	-	-	0,08	0,15	0,2	0,23	0,3	0,38	0,43
	Ghisa temprata	temprato	2090	-	-	-	-	-	-	-	-	-

I parametri di taglio indicati sono da considerarsi come valori massimi ed in ottimali condizioni di lavoro (stabilità sistema, qualità e pressione refrigerante, buona truciolabilità del materiale). Combinare a questi parametri di taglio gli accorgimenti relativi al refrigerante riportati a pagina 107. Per ulteriore supporto tecnico contattare i tecnici ARNO.

Inserti in metallo duro

ISO	Materiale	Carico di rottura [N/mm²]	Velocità di taglio V <sub>c</sub>		Serie A, C 9,5 - 12,53 [mm/giro]	Serie E, G 12,98 - 17,53 [mm/giro]	Serie I, K 17,53 - 24,38 [mm/giro]	Serie M, O 24,41 - 35,00 [mm/giro]	Serie Q 35,00 - 47,8 [mm/giro]
			TiCN [m/min]	TiAlN [m/min]					
P	Acciaio non legato o da fusione p. e. 9SMn28; 9SMnPb28; 10SPb20	fino a 500	115	125	0,15	0,21	0,28	0,35	0,43
		500 - 850	90	105	0,13	0,21	0,28	0,35	0,43
	Acciaio da costruzione p. e. St33; St37-2; St44-2; St52; St60	350 - 500	85	95	0,13	0,21	0,26	0,3	0,38
		500 - 850	68	75	0,11	0,2	0,21	0,26	0,34
	Acciaio non legato o debolmente legato, acciaio al carbonio o acciaio stampato p. e. C15; C22; 20Mn5; Ck45	850 - 1200	62	70	0,09	0,17	0,2	0,21	0,3
		bis 450	110	120	0,13	0,2	0,26	0,32	0,4
		450 - 750	85	95	0,11	0,17	0,21	0,31	0,38
		750 - 900	70	85	0,11	0,17	0,21	0,31	0,38
	Acciaio legato p. e. 42CrMo4; 16MnCr5; 36CrNiMo4 14NiCrMo13-4; Ck75; Ck101; 17CrNiMo8, 35CrMo4; 41Cr4; 50MnSi4	900 - 1100	60	70	0,09	0,15	0,2	0,26	0,34
		bis 600	90	100	0,13	0,17	0,21	0,31	0,36
		600 - 800	80	90	0,11	0,17	0,21	0,31	0,36
		800 - 950	70	85	0,11	0,15	0,21	0,31	0,36
950 - 110		67	75	0,09	0,13	0,2	0,26	0,31	
Acciaio fortemente legato p. e. 41CrAlMo7; 36CrNiMo4; 32NiCrMo14-5	1100 - 1250	60	65	0,07	0,13	0,2	0,26	0,31	
	600 - 1000	55	60	0,11	0,15	0,2	0,21	0,3	
	1000 - 1200	50	55	0,09	0,11	0,2	0,21	0,3	
Acciaio da utensili p. e. C75W; 102Cr6; 105WCr6; X153CrMoV12	1200 - 1350	44	50	0,07	0,09	0,17	0,2	0,26	
	500 - 700	60	65	0,09	0,13	0,17	0,21	0,26	
M	Acciaio inossidabile ed acciaio da fusione	austenitico e austenitico/ferritico	500 - 700	60	65	0,09	0,13	0,17	0,21
		temprato	700 - 950	45	50	0,09	0,13	0,17	0,21
K	Ghisa p. e. GG25; GG40	perlitica, ferritica	450 - 610	58	65	0,09	0,16	0,19	0,24
		perlitica, martensitica	610 - 930	44	50	0,09	0,14	0,16	0,2
	Ghisa grigia sferoidale p. e. GGG50	ferritica	500 - 700	103	123	0,14	0,2	0,26	0,37
		perlitica	700 - 850	80	95	0,1	0,16	0,19	0,26
Ghisa malleabile p. e. GTS70	ferritica	850 - 1100	70	84	0,1	0,14	0,16	0,22	
	perlitica	540	100	120	0,12	0,17	0,2	0,29	
N	Leghe di Alluminio a truciolo lungo p. e. AlMgSiPb; AlCuMg1; AlMgSi1	non temprabile	850	75	95	0,1	0,14	0,18	0,26
		temprabile, temprato	450	105	125	0,12	0,17	0,2	0,29
	Leghe di Alluminio da getti p. e. G-AlSi10Mg; G-ALSi12	≤ 12 % Si, temprato	450	105	125	0,12	0,17	0,2	0,29
		≤ 12 % Si, temprabile, temprato	200	410	450	0,1	0,17	0,27	0,33
		≤ 12 % Si, non temprabile	335	275	305	0,12	0,29	0,37	0,52
	Rame e leghe di rame (ottone / bronzo)	Legate al piombo, Pb > 1 %	250	400	450	0,2	0,31	0,4	0,48
		Ottone / Bronzo	300	350	380	0,2	0,3	0,4	0,48
		Bronzo alluminio	450	250	280	0,18	0,28	0,36	0,46
		Rame e rame elettrolitico	370	130	145	0,15	0,23	0,28	0,38
			300	160	185	0,16	0,24	0,29	0,39
	Materiali non ferrosi	Plastiche dure	500	100	110	0,14	0,2	0,26	0,37
		Plastiche rinforzate	200	100	120	0,05	0,09	0,1	0,16
Gomme dure		200	100	120	0,05	0,09	0,1	0,16	
S	Leghe esotiche resistenti alle alte temperature p. e. Inconell, Hasteloy, Nimonic, Waspaloy, Monel	Fe-legate ricotto	700	29	32	0,08	0,16	0,2	0,24
		temprato	980	-	-	-	-	-	-
		Ni o ricotto	850	29	32	0,08	0,16	0,2	0,24
		Co legato stampato	1100	-	-	-	-	-	-
	Leghe di titanio, Titanio p. e. Ti99,5; Ti Al6V4; TiCu2	temprato	1230	21	25	0,08	0,12	0,16	0,18
		temprato	500 - 700	33	39	0,09	0,16	0,19	0,24
H	Acciaio temprato	700 - 1050	29	34	0,09	0,14	0,16	0,22	
		1020 - 1365	40	44	0,09	0,14	0,22	0,25	
	Ghisa temprata	1365 - 1850	24	26	0,06	0,11	0,16	0,22	
		stampato	1365	30	35	0,07	0,12	0,18	0,22
Ghisa temprata	temprato	2090	-	-	-	-	-	-	

I parametri di taglio indicati sono da considerarsi come valori massimi ed in ottimali condizioni di lavoro (stabilità sistema, qualità e pressione refrigerante, buona truciolabilità del materiale). Combinare a questi parametri di taglio gli accorgimenti relativi al refrigerante riportati a pagina 107. Per ulteriore supporto tecnico contattare i tecnici ARNO.

Inserti a fondo piano

ISO	Materiale	Carico di rottura [N/mm²]	Velocità di taglio V <sub>c</sub>		Serie A, C 9,5 – 12,53 [mm/giro]	Serie E, G 12,98 – 17,53 [mm/giro]	Serie I, K 17,53 – 24,38 [mm/giro]	Serie M, O 24,41 – 35,00 [mm/giro]	Serie Q 35,00 – 47,8 [mm/giro]
			TiCN [m/min]	TiAlN [m/min]					
P	Acciaio non legato o da fusione p. e. 9SMn28; 9SMnPb28; 10SPb20	fino a 500	–	69	0,14	0,2	0,26	0,33	0,41
		500 - 850	–	58	0,12	0,2	0,26	0,33	0,41
	Acciaio da costruzione p. e. St33; St37-2; St44-2; St52; St60	350 - 500	–	48	0,12	0,2	0,24	0,28	0,36
		500 - 850	–	41	0,1	0,18	0,2	0,24	0,32
		850 - 1200	–	34	0,08	0,16	0,18	0,2	0,28
	Acciaio non legato o debolmente legato, acciaio al carbonio o acciaio stampato p. e. C15; C22; 20Mn5; Ck45	bis 450	–	59	0,12	0,18	0,24	0,3	0,38
		450 - 750	–	56	0,1	0,16	0,2	0,29	0,36
		750 - 900	–	52	0,1	0,16	0,2	0,29	0,36
		900 - 1100	–	48	0,08	0,14	0,18	0,24	0,32
	Acciaio legato p. e. 42CrMo4; 16MnCr5; 36CrNiMo4 14NiCrMo13-4; Ck75; Ck101; 17CrNiMo8, 35CrMo4; 41Cr4; 50MnSi4	bis 600	–	52	0,12	0,16	0,2	0,29	0,34
		600 - 800	–	48	0,1	0,16	0,2	0,29	0,34
		800 - 950	–	44	0,1	0,14	0,2	0,29	0,34
		950 - 110	–	41	0,08	0,12	0,18	0,24	0,3
		1100 - 1250	–	38	0,06	0,12	0,18	0,24	0,3
Acciaio fortemente legato p. e. 41CrAlMo7; 36CrNiMo4; 32NiCrMo14-5	600 - 1000	–	28	0,1	0,14	0,18	0,2	0,28	
	1000 - 1200	–	22	0,08	0,1	0,18	0,2	0,28	
	1200 - 1350	–	18	0,06	0,09	0,16	0,18	0,24	
Acciaio da utensili p. e. C75W; 102Cr6; 105WCr6; X153CrMoV12	500 - 700	–	28	0,08	0,12	0,16	0,2	0,24	
	700 - 950	–	22	0,08	0,12	0,16	0,2	0,24	
M	Acciaio inossidabile ed acciaio da fusione	austenitico e austenitico/ferritico	450 - 610	–	26	0,14	0,19	0,2	0,25
		temprato	610 - 930	–	23	0,1	0,15	0,19	0,22
K	Ghisa p. e. GG25; GG40	perlitica, ferritica	500 - 700	–	60	0,14	0,24	0,3	0,42
		perlitica, martensitica	700 - 850	–	47	0,1	0,15	0,2	0,25
			850 - 1100	–	38	0,1	0,12	0,15	0,2
	Ghisa grigia sferoidale p. e. GGG50	ferritica	540	–	58	0,14	0,24	0,29	0,4
		perlitica	850	–	47	0,1	0,16	0,19	0,24
	Ghisa malleabile p. e. GTS70	ferritica	450	–	66	0,14	0,24	0,29	0,4
		perlitica	780	–	47	0,1	0,16	0,19	0,24
N	Leghe di Alluminio a truciolo lungo p. e. AlMgSiPb; AlCuMg1; AlMgSi1	non temprabile	200	–	230	0,18	0,29	0,37	0,44
		temprabile, temprato	335	–	120	0,19	0,29	0,37	0,42
	Leghe di Alluminio da getti p. e. G-ALSi10Mg; G-ALSi12	≤ 12 % Si, temprato	250	–	210	0,17	0,29	0,37	0,44
		≤ 12 % Si, temprabile, temprato	300	–	160	0,17	0,29	0,37	0,43
	Rame e leghe di rame (ottone / bronzo)	Legate al piombo, Pb > 1 %	370	–	70	0,16	0,26	0,38	0,45
		Ottone / Bronzo	300	–	68	0,15	0,25	0,37	0,44
		Bronzo alluminio	500	–	60	0,14	0,24	0,3	0,42
		Rame e rame elettrolitico	200	–	45	0,06	0,09	0,16	0,2
	Materiali non ferrosi	Plastiche dure	I parametri di taglio dipendono dalla quantità di refrigerante disponibile. Come parametri di partenza utilizzare dati per leghe di alluminio a truciolo lungo.						
		Plastiche rinforzate							
		Gomme dure							
S	Leghe esotiche resistenti alle alte temperature p. e. Inconell, Hasteloy, Nimonic, Waspaloy, Monel	Fe-legate ricotto	700	–	10	0,08	0,14	0,17	0,22
		temprato	980	–	–	–	–	–	–
		Ni o ricotto	850	–	9	0,08	0,13	0,15	0,19
		Co legato stampato	1100	–	–	–	–	–	–
		temprato	1230	–	8	0,07	0,12	0,14	0,17
	Leghe di titanio, Titanio p. e. Ti99,5; Ti Al6V4; TiCu2	Titanio puro	500 - 700	–	15	0,09	0,15	0,19	0,24
			700 - 1050	–	12	0,09	0,14	0,15	0,19
H	Acciaio temprato	temprato	1020 - 1365	–	20	0,09	0,14	0,19	0,2
		temprato	1365 - 1850	–	13	0,09	0,1	0,15	0,19
	Ghisa temprata	stampato	1365	–	18	0,09	0,12	0,16	0,19
	Ghisa temprata	temprato	2090	–	–	–	–	–	–

I parametri di taglio indicati sono da considerarsi come valori massimi ed in ottimali condizioni di lavoro (stabilità sistema, qualità e pressione refrigerante, buona truciolabilità del materiale). Combinare a questi parametri di taglio gli accorgimenti relativi al refrigerante riportati a pagina 107. Per ulteriore supporto tecnico contattare i tecnici ARNO.

ISO	Materiale	Refrigerante Pressione [bar] Portata [litre/min]	Inserto acciaio super rapido (HSS)							Inserto metallo duro				
			Serie A, C 9,5-12,95	Serie E, G 12,98-17,53	Serie I, K 17,53-24,38	Serie M, O 24,41-35,00	Serie Q 35,00-47,80	Serie S 47,85-65,00	Serie U, W 66,00-114,48	Serie A, C 9,5-12,95	Serie E, G 12,98-17,53	Serie I, K 17,53-24,38	Serie M, O 24,41-35,00	Serie Q 35,00-47,80
P	Acciaio non legato o da fusione	[bar] [litre/min]	12 10	6 10	7 16	6 27	5 45	3 114	3 144	12 10	7 11	7 17	7 30	7 60
	Acciaio da costruzione	[bar] [litre/min]	11 9	6 10	6 16	5 23	5 45	3 114	3 144	12 10	7 11	6 16	6 27	5 47
	Acciaio non legato o debolmente legato, acciaio al carbonio o acciaio stampato	[bar] [litre/min]	11 9	4 11	4 12	2 19	2 30	2 87	2 98	11 9	4 10	4 12	4 19	3 40
	Acciaio legato	[bar] [litre/min]	12 9	6 10	5 14	4 23	4 38	2 98	2 117	15 11	10 13	10 22	9 34	7,5 56
	Acciaio fortemente legato	[bar] [litre/min]	11 9	5 8	4 12	2 20	2 30	2 87	2 98	15 11	5 12	4 13	4 20	3 40
	Acciaio da utensili	[bar] [litre/min]	11 10	4 8	4 12	3 20	2 30	2 87	2 98	15 11	5 12	4 13	3 20	3 37
M	Acciaio inossidabile ed acciaio da fusione	[bar] [litre/min]	12 10	6 10	5 14	4 23	4 38	2 98	2 117	15 11	10 13	10 22	9 34	9 70
K	Ghisa	[bar] [litre/min]	11 9	5 9	4 13	3 19	2 34	2 98	2 106	11 9	5 9	5 12	5 19	4 49
	Ghisa grigia sferoidale	[bar] [litre/min]	11 9	5 9	4 13	3 19	2 34	2 98	2 106	11 9	5 9	5 12	5 19	4 49
	Ghisa malleabile	[bar] [litre/min]	11 9	5 9	4 13	3 19	2 34	2 98	2 106	11 9	5 9	5 13	5 19	4 49
N	Leghe di Alluminio a truciolo lungo	[bar] [litre/min]	15 10	12 14	16 23	11 34	9 61	4 125	4 159	22 13	19 17	19 28	17 45	14 77
	Leghe di Alluminio da getti	[bar] [litre/min]	15 10	12 14	16 23	11 34	9 61	4 125	4 159	22 13	19 17	19 28	17 45	14 77
	Rame e leghe di rame (ottone / bronzo)	[bar] [litre/min]	13 10	8 11	10 20	8 30	7 53	4 125	4 167	14 10	10 13	10 21	10 34	10 75
	Materiali non ferrosi	[bar] [litre/min]	Utilizzo di aria raccomandato.											
S	Leghe esotiche resistenti alle alte temperature	[bar] [litre/min]	11 9	4 11	4 12	2 19	2 30	2 87	2 98	18 10	11 11	10 12	10 19	9 62
	Leghe di titanio, Titanio	[bar] [litre/min]	11 9	5 9	4 12	2 19	2 30	2 98	2 125	18 10	11 11	10 16	10 27	9 62
H	Acciaio temprato	[bar] [litre/min]	11 9	4 11	4 12	2 19	2 30	2 87	2 98	11 9	4 10	4 12	3 19	3 37
	Ghisa temprata	[bar] [litre/min]	11 9	4 11	4 12	2 19	2 30	2 87	2 98	11 9	4 10	4 12	3 19	3 37
	Ghisa temprata	[bar] [litre/min]	- -	- -	- -	- -	- -	- -	- -	- -	- -	- -	- -	- -

Questi suggerimenti consentono un'ottima durata utensile e evacuazione truciolo. Con valori più bassi si deve prestare attenzione all'usura e all'evacuazione truciolo. Se necessario le velocità e gli avanzamenti dovranno essere ridotti.

Informazione: Prego notare che i valori di portata del refrigerante sono riferiti ad una profondità di foratura 8xD.

Per fori più profondi moltiplicare i valori raccomandati come segue: da 8 a 12xD moltiplicare per 1.3 da 12 a 20xD moltiplicare per 2.0 oltre 20xD moltiplicare per 3.



## Anbohren oder Zentrieren / Sport drill / Foro di centraggio

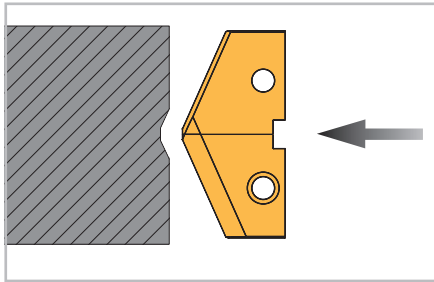

Die Bohrplatte unseres „SHARK-Drill“-Bohrers sind stark ausgespitzt, sodass ein Anzentrieren erst ab 8xD Bohrtiefe erforderlich ist.

**Achtung: Spitzen** der Bohrplatten: bis  $\varnothing 65 \text{ mm} = 132^\circ$  bis  $\varnothing 114 \text{ mm} = 144^\circ$  Der Zentrierbohrer muss einen gleichen oder größeren Spitzenwinkel haben.

The inserts for our “SHARK-Drill” got a self-centering point. To spot the hole is only required when you drill deeper than 8xD.

Attention: Point inserts: up to  $\varnothing 65 \text{ mm} = 132^\circ$  up to  $\varnothing 114 \text{ mm} = 144^\circ$  The spot drill must have the same or a bigger spot.

Gli inserti del sistema “SHARK-Drill” possono eseguire anche il foro da centro. Eseguire un foro da centro è suggerito per fori con profondità superiore a 8xD o in condizioni di centraggio difficili.

Attenzione: Inserti con cuspidi: fino a  $\varnothing 65 \text{ mm} = 132^\circ$  fino a  $\varnothing 114 \text{ mm} = 144^\circ$  Il foro da centro deve avere identico o maggiore angolo di cuspidi.

## Verlaufen des Bohrers / Holder deflection / Deviazione del foro

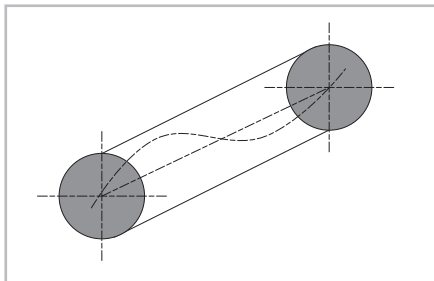

Das „Verlaufen“ des Bohrers ist von mehreren Faktoren abhängig:

- Werkstückspannung
- Werkzeugspannung
- Homogenität des Materials
- Durchmesser/Bohrtiefenverhältnis

The run out of the drill is depending on several issues:

- Component clamping
- Tool clamping
- Material
- Diameter / depth ratio

La deviazione dell'utensile dipende da diversi fattori:

- Staffaggio del pezzo
- Serraggio dell'utensile
- Materiale
- Rapporto Diametro / Profondità

## Spanbruch bei zähen Materialien / Chipping in tough materials / Evacuazione in materiali difficili



Viele Stähle mit hohen Cr- und Ni- Anteilen können allein durch die Spanbrecher und Spanformer nicht gebrochen werden. Es hilft einzig (aber zuverlässig) ein Spanzyklus:

- Rückzugweg 0,1 mm bleibt immer gleich!
- Bohrerweg so anpassen, dass Späne problemlos ausgespült werden!

Many steels with high Cr and Ni content can only be drilled with a peck cycle:

- 0.1 mm back is always the same
- Drill depth in the peck cycle should not be too long (coolant must float out the chips)

Molti materiali con elevato contenuto di Cr e Ni, possono venire forati solamente con cicli di scarico truciolo:

- 0,1 mm di ritorno è il valore suggerito
- La profondità di ogni foratura del ciclo non deve mai essere troppo lunga (il refrigerante deve far evacuare il truciolo)

## Niedriger Kühlmitteldruck / Low coolant pressure / Bassa pressione del refrigerante

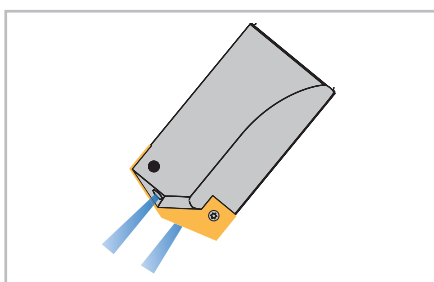

Bei niedrigem Kühlmitteldruck müssen die Schnittwerte nach unten korrigiert werden. Das Kühlmittel ist bei diesem Werkzeug für die Spanausbringung sehr wichtig. Ohne innere Kühlmittelzufuhr ist die Funktion nur bis 1,5xD Bohrtiefe gewährleistet.

**Achtung:** Je mehr Kühlmitteldruck und -menge umso besser!

With low coolant supply, speeds and feeds must be reduced. Internal coolant supply is necessary over 1.5xD drill depth.

Attention: High coolant pressure and volume give you better results.

Con basse pressioni del refrigerante, velocità ed avanzamenti vanno ridotti. Per forature superiori a 1,5xD è indispensabile l'adduzione interna del refrigerante.

Attenzione: Pressione e portata elevate del refrigerante offrono sempre risultati migliori.



**Unterbrochener Schnitt oder schräges Anbohren / Interrupted cutting / Taglio interrotto**

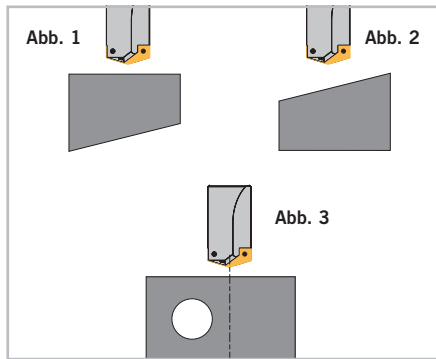

**Unterbrochener Schnitt oder schräges Anbohren wird nicht empfohlen, da die Abstützung der Bohrerplatte nur relativ gering ist!**

**Abb. 1+2: Unter Reduzierung der Schnittwerte bis  $\sphericalangle$  7° teils möglich.  
Abb. 3: Fast unmöglich! Besprechen Sie mit uns Ihren Anwendungsfall, wir versuchen eine Lösung zu finden!**

*Interrupted cutting is not recommended. Due lead of you may get damaged holders, excessive lead wear, oversize holes.*

*Pic. 1+2: By reduction speed, it may possible up to  $\sphericalangle$  7°. Pic. 3: Nearly impossible. Please call our Application Helpline. We try to find a solution.*

Il taglio interrotto non è consigliato. Questo perché si possono danneggiare i portautensili, usurare precocemente gli inserti ed i fori possono risultare maggiorati.

Fig. 1+2: Riducendo la velocità, possibile fino a  $\sphericalangle$  7°. Fig. 3: Non possibile. Chiamare il supporto tecnico per una soluzione.



**Ausbrüche an der Bohrplatte / Fracture of inserts / Rotture di inserti**

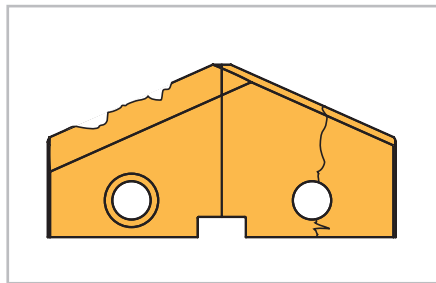

**Bricht die Bohrplatte aus oder zerbricht völlig, so ist die gewählte Qualität zu hart für die Anwendung. Stellen Sie auf eine zähere Qualität um (z. B. von Hartmetall auf HSS) oder ändern Sie etwas an den Rahmenbedingungen (wenn möglich unterbrochenen Schnitt vermeiden). Hartmetall nur unter stabilen Rahmenbedingungen einsetzen.**

*When the insert fracture, the Quality (Grade) is too brittle for the Application. Please use a tougher grade (for example: from Carbide to HSS) or change the cutting environment. Use Carbide only when workholding is stable and the drill depth is  $< 5 \times D$ . Also a high quality machine is necessary.*

Quando l'inserto si frattura significa che la qualità che si sta utilizzando (grado) è troppo fragile per l'applicazione che si sta eseguendo. Utilizzare un grado più tenace (per esempio sostituire la cuspide in metallo duro con una in HSS) o modificare le condizioni di taglio. Utilizzare le cuspidi di foratura in metallo duro solamente quando il sistema di staffaggio è stabile e la profondità di foratura è  $< 5 \times D$ . E' anche necessario lavorare con una macchina utensile di qualità elevata.

**Ausbrennen der Platte (HSS) / Accelerated insert wear / Precoce usura degli inserti**

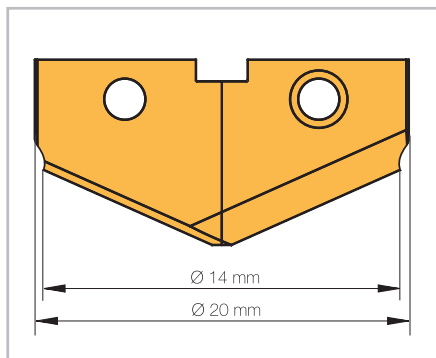

**Bsp.: Bohren in C45 mit P120 HSS5 / TiAlN: n = 850 U/min f = 0,25 mm**  
*E.g.: C45 with P120 HSS5 / TiAlN: rev = 850 1/min f = 0.25 mm/rev*  
*Es.: C45 con P120 HSS5 / TiAlN: n = 850 U/min f = 0,25 mm/giro*

$$V_c = \frac{n \times \pi \times D}{1000} = \frac{850 \times \pi \times 14}{1000} = 37 \text{ m/min}$$

somit für Ø 20 mm for dia. 20 mm per Ø 20 mm

$$n = \frac{37 \times 1000}{\pi \times D} = 588 \text{ U/min}$$

**d.h.: Eine Drehzahl von 588 U/min wäre für Ø 20 mm unter den gegebenen Bedingungen (Kühlmittel, Material, Aufspannung) die „richtige“ Drehzahl.**

*i.e.: 588 rev/min would have been the right speed in this application.  
 p.e.: 588 g/min è la velocità corretta a cui deve girare la punta per questa applicazione.*

Wenn die Platte in dieser Art und Weise verschlissen ist, war entweder der Kühlmittel- druck zu gering oder der Werkstoff wurde falsch eingeschätzt. Sofern möglich, verwenden Sie eine härtere Sorte. Da an der Bohrer- spitze kein Verschleiß zu sehen ist, war der Vorschub korrekt aber die Drehzahl bei den gegebenen Rahmenbedingungen zu hoch.

*On the drill insert is no wear, that shows the feedrate was ok, the revolutions are too high in this cutting environment.*

Se sugli inserti sono presenti segni di usura significa che si sta lavorando con una velocità di avanza-mento adatta ma con velocità di taglio troppo elevata per queste condizioni di lavoro.

Anhand des Ø 14 mm im Beispiel, der bei der angewandten Drehzahl noch „stehen“ bleibt, kann man für den Ø 20 mm die richtige Drehzahl zurückrechnen.

*With the dia. 14 mm in the example, the rest dia, you can calculate back, what would have been the correct speed for the original dia. 20 mm.*

Dall' esempio si può capire che al momento si sta lavorando con una velocità di taglio appropriata per un dia. 14 mm e non per un dia. 20 mm.

## EINSATZHINWEISE FÜR ...

### ... (extra-) kurze bis Standard-Halter beim Bohrsystem SHARK-Drill®

Um eine einwandfreie Funktion der Bohrer zu gewährleisten, hat sich folgende Vorgehensweise bewährt:

- 1) Erforderlichen Kühlmitteldruck sowie das benötigte Durchflussvolumen prüfen und ggf. anpassen (siehe Seite 99).
- 2) Bereits bei der ersten Bohrung Spanbruch- und Schnittwertoptimierung durchführen. Ziel sind kurze und leicht ausspülbare Späne.
- 3) Messen der Bohrung und überprüfen, ob die empfohlene Toleranz eingehalten wird.
- 4) Während der Bearbeitung ständig sicherstellen, dass die Späne kurz sind und locker ausgespült werden. Gegebenenfalls ist ein Bohrzyklus erforderlich.

**Immer den kürzest möglichen Bohrer wählen!**

Achtung: Hartmetallplatten sind normalerweise bis ca. **6 bis 7 x D** Tiefe einsetzbar!

**Spanentwicklung** – Folgende Vorgehensweise hat sich als vorteilhaft erwiesen:

- Spanentwicklung beobachten.
- Falls der max. Vorschub noch nicht erreicht ist, bringt eine Vorschuberrhöhung oftmals einen besseren Spanbruch.
- Sollte keine dieser Maßnahmen zum Erfolg führen, bietet sich ein Spanbruchzyklus an.

Viele Materialien aus dem Bereich der rostfreien Stähle, aber zum Teil auch andere Materialien, lassen sich nicht allein über „V<sub>c</sub>“ und „f“ zum brechen bringen. In solchen Fällen ist der Einsatz eines Spanbruchzyklus erforderlich.

Dieser sollte nur eine kleine Spanunterbrechung beinhalten (mit ca. 0,1 mm Abhebemaß). Ein Tieflochbohrzyklus mit Rückzugsebene außerhalb des Werkstücks ist nicht empfehlenswert. Als inkrementelles Zustellmaß (erster Richtwert) kann ca. 10% des Bohrdurchmessers empfohlen werden (z. B. 20 mm Bohrdurchmesser = Zustellmaß 2 mm).

## EINSATZHINWEISE FÜR ...

### ... überlange Halter beim Bohrsystem SHARK-Drill®

Um eine einwandfreie Funktion der Bohrer zu gewährleisten, hat sich folgende Vorgehensweise bewährt:

- 1) Pilotbohrung (ca. 1 x D) im gleichen Durchmesser setzen. Spitzenwinkel größer/gleich SHARK-Drill® Bohrer. Weitere Startmöglichkeiten sind:
  - Anzentrieren mit 132° Spitzenwinkel (bis Ø 65 mm).
  - Anzentrieren mit 144° Spitzenwinkel (bis Ø 65-114 mm).
  - Behutsames Anbohren (mit ca. 50% des empfohlenen Vorschubs) bis zum Erreichen des vollen Durchmessers.
- 2) Spanbruch- und Schnittwertoptimierung bereits vor dem Einsatz (möglichst mit der Pilotbohrung) durchführen. Ziel sind kurze und leicht ausspülbare Späne. Schnittwerte wie folgt anpassen:
 

	8 – 11 x D	12 – 14 x D
V <sub>c</sub> [m/min]	0,9	0,58
f [mm/U]	x	0,9
- 3) Die Kühlmittlempfehlungen (siehe Seite 99) sind mit folgenden Multiplikatoren zu verwenden: SHARK-Drill® (8 – 11 x D) x 1,3 / (12 – 14 x D) x 1,5.
- 4) Messen der Bohrung und überprüfen, ob die Toleranz eingehalten wird.
- 5) Schnittwerte auf die zuvor getesteten Werte steigern und fertig bohren. Dabei sicherstellen, dass die Späne kurz sind und ständig locker ausgespült werden. Gegebenenfalls ist ein Bohrzyklus erforderlich.

**Immer den kürzest möglichen Bohrer wählen!**

Achtung: Der Einsatz von Hartmetallplatten ist hier unter Umständen nicht empfehlenswert!

**Spanentwicklung** – Folgende Vorgehensweise hat sich als vorteilhaft erwiesen:

- Spanentwicklung beobachten.
- Falls der max. Vorschub noch nicht erreicht ist, bringt eine Vorschuberrhöhung oftmals einen besseren Spanbruch.
- Sollte keine dieser Maßnahmen zum Erfolg führen, bietet sich ein Spanbruchzyklus an.

Viele Materialien aus dem Bereich der rostfreien Stähle, aber zum Teil auch andere Materialien, lassen sich nicht allein über „V<sub>c</sub>“ und „f“ zum brechen bringen. In solchen Fällen ist der Einsatz eines Spanbruchzyklus erforderlich.

Dieser sollte nur eine kleine Spanunterbrechung beinhalten (mit ca. 0,1 mm Abhebemaß). Ein Tieflochbohrzyklus mit Rückzugsebene außerhalb des Werkstücks ist nicht empfehlenswert. Als inkrementelles Zustellmaß (erster Richtwert) kann ca. 10% des Bohrdurchmessers empfohlen werden (z. B. 20 mm Bohrdurchmesser = Zustellmaß 2 mm).

## EINSATZHINWEISE FÜR ...

## ... extrem lange Halter beim Bohrsystem SHARK-Drill®

Um eine einwandfreie Funktion der Bohrer zu gewährleisten, hat sich folgende Vorgehensweise bewährt:

1) Pilotbohrung (ca. 1 bis 2xD) im gleichen Durchmesser setzen. Spitzenwinkel größer/gleich SHARK-Drill® Bohrer.

Weitere Startmöglichkeiten sind:

- Anzentrieren mit 132° Spitzenwinkel (bis Ø 65 mm) – behutsames Anbohren (mit ca. 50% des empfohlenen Vorschubes) bis zum Erreichen des vollen Durchmessers.
- Anzentrieren mit 144° Spitzenwinkel (bei Ø 65 – 114 mm) – behutsames Anbohren (mit ca. 50% des empfohlenen Vorschubes) bis zum Erreichen des vollen Durchmessers.

2) Spanbruch und Schnittwertoptimierung bereits vor dem Einsatz des langen Bohrers. Dafür wird am besten der Pilotbohrer verwendet. Ziel sind kurze, leichte Späne, die einfach ausgespült werden können.

3) Erforderlichen Kühlmitteldruck und Durchflussmenge prüfen. Die Kühlmittelempfehlungen (siehe Seite 99) sind mit folgenden Multiplikatoren zu verwenden:

SHARK-Drill® (20 – 24xD) x 2,0 / (25 – 32xD) x 3,0.

4) Schnittwerte wie folgt anpassen:

	20 – 24xD	25 – 32xD
V <sub>c</sub> [m/min]	0,80	0,75
f [mm/U]	0,80	0,80

5) Mit dem langen Bohrer stehend oder mit 10 – 20 U/min in die Bohrung einfahren.

6) Schnittwerte auf die vorher getesteten Werte hochfahren und fertig bohren. Dabei sicherstellen, dass die Späne kurz sind und ständig locker ausgespült werden. Gegebenenfalls ist ein (weiterer) Bohrzyklus erforderlich.

7) Nach dem Erreichen der Endbohrtiefe, die Spindel stoppen oder mit 10 – 20 U/min aus der Bohrung herausfahren.

8) Bitte beachten Sie ein mögliches Verlaufen des Bohrers dieser Länge.

**Spanentwicklung** – Folgende Vorgehensweise hat sich als vorteilhaft erwiesen:

Bis zu einer Bohrtiefe von 1 bis 2xD die Spanentwicklung beobachten. Bei zu langen Spänen die Schnittwerte anpassen.

Viele Materialien aus dem Bereich der rostfreien Stähle, aber zum Teil auch andere Materialien, lassen sich nicht allein über „V<sub>c</sub>“ und „f“ zum Brechen bringen. In solchen Fällen ist der Einsatz eines Spanbruchzyklus erforderlich.

Dieser sollte nur eine kleine Spanunterbrechung beinhalten (mit ca. 0,1 mm Abhebemaß). Ein Tieflochbohrzyklus mit Rückzugsebene außerhalb des Werkstücks ist nicht empfehlenswert. Als inkrementelles Zustellmaß (erster Richtwert) kann ca. 10% des Bohrdurchmessers empfohlen werden (z. B. 20 mm Bohrdurchmesser = Zustellmaß 2 mm).

**Tipp:**

Falls die Vorschubwerte vorher nicht schon grenzwertig waren, bringt eine Vorschuberhöhung oftmals einen besseren Spanbruch. Sollte dies nicht zum Erfolg führen, bietet sich ein Spanbruchzyklus an.

## RECOMMENDATIONS FOR ...

## ... SHARK-Drill® (extra) short to standard holder

In order to obtain a problem free machining with the drills, the following has proven successful:

- 1) Check and possibly adjust coolant pressure (see page 103).
- 2) Immediately after the first cut we suggest a chip breaking and cutting data review. The target should be short and easily removable swarf.
- 3) Measure the hole and check that tolerance is acceptable.
- 4) During the machining always ensure that the swarf is short and removed from the hole. Otherwise a pecking cycle may be required.

**Always select shortest possible drill!**

Important: Carbide inserts only suitable up to approx.  $6 - 7 \times D$ .

**Swarf control** – The following recommendations have also proved advantageous:

- Monitor swarf control.
- If not yet at maximum feed rate potential, an increase in feed rate can lead to better chip breaking.
- If none of these changes are successful it may be necessary to insert a pecking cycle.

For many materials in the stainless steel area, but also others, it may not always be possible to achieve acceptable chip breaking simply by adjusting  $V_c$  and  $f$ . In such cases a pecking cycle will be needed. This should only be a small peck cycle of approx 0.1 mm.

A pecking cycle where the tool is removed out of the hole is not recommended. As a rule take increments of approx 10% of the drill diameter (e.g. 20 mm diameter = 2 mm peck depth).

## RECOMMENDATIONS FOR ...

## ... the extended SHARK-Drill®

In order to obtain a problem free machining with the drills, the following has proven successful:

- 1) Pilot drilling (approx.  $1 \times D$ ) with same diameter. The drill point should be same or larger than SHARK-Drill® insert. Other start options:
  - Centering with 132 degree drill point (up to 65 mm).
  - Centering with 144 degree drill point (from 64 – 114 mm).
  - Careful penetration (approx 50% of recommended feed rate) until full diameter is achieved.

- 2) Chip breaking and cutting data optimizing before starting. Target is short and easy to evacuate swarf. Modify cutting data as below:

	8 – 11 x D	12 – 14 x D
$V_c$ [m/min]	0.9	0.58
$f$ [mm/U]	x	0.9

- 3) Check the coolant pressure and flow rate. The coolant pressure (see page 103) can be adjusted using the following formula: SHARK-Drill® ( $8 - 11 \times D$ )  $\times 1.3 / (12 - 14 \times D) \times 1.5$ .
- 4) Measure the hole and check that tolerance is acceptable.
- 5) Increase cutting data to previously established data and finish drilling, making sure that the swarf remains short and leaving the hole problem free. Otherwise a peck cycle may be required.

**Always select shortest possible drill!**

Attention: Carbide inserts are not recommended.

**Swarf control** – The following recommendations have also proved advantageous:

- Monitor swarf control.
- If not yet at maximum feed rate potential, an increase in feed rate can lead to better chip breaking.
- If none of these changes are successful it may be necessary to insert a pecking cycle.

For many materials in the stainless steel area, but also others, it may not always be possible to achieve acceptable chip breaking simply by adjusting  $V_c$  and  $f$ . In such cases a pecking cycle will be needed. This should only be a small peck cycle of approx 0.1 mm.

A pecking cycle where the tool is removed out of the hole is not recommended. As a rule take increments of approx 10% of the drill diameter (e.g. 20 mm diameter = 2 mm peck depth).

## RECOMMENDATIONS FOR ...

## ... the extreme long SHARK-Drill®

In order to obtain a problem free machining with the drills, the following has proven successful:

- 1) Pilot drilling (approx. 1 x D) with same diameter. The drill point should be same or larger than SHARK-Drill® insert.  
Other start options:
  - Centering with 132 degree drill point (up to 65 mm) – careful penetration (approx. 50% of recommended feed rate) until full diameter is achieved.
  - Centering with 144 degree drill point (from 64 – 114 mm) – careful penetration (approx. 50% of recommended feed rate) until full diameter is achieved.
- 2) Swarf control and cutting data optimizing should be performed before full depth drilling, we suggest using the pilot drill. The target short and easily evacuated swarf.
- 3) Check the coolant pressure and flow rate. The coolant pressure (see page 103) can be adjusted using the following formula: SHARK-Drill® (20 – 24 x D) x 2.0 / (25 – 32 x D) x 3.0.
- 4) The cutting data should also be modified depending on drill depth:
 

	20 – 24 x D	25 – 32 x D
V <sub>c</sub> [m/min]	0.80	0.75
f [mm/U]	0.80	0.80
- 5) With the long drill stationary or penetration with 10 – 20 rev./min.
- 6) Increase cutting data to previously established data and finish drilling, making sure that the swarf remains short and leaving the hole problem free. Otherwise a peck cycle may be required.
- 7) When reaching the depth required stop the spindle or reduce to 10 – 20 rev./min and feed out the drill.
- 8) Note that the extra long and extreme long drills do deflect.

**Swarf control** – The following recommendations have also proved advantageous:  
Up to drill depth of 1 – 2 x D monitor swarf. If the swarf is too long, cutting data should be modified.

For many materials in the stainless steel area, but also others, it may not always be possible to achieve acceptable chip breaking simply by adjusting V<sub>c</sub> and f. In such cases a pecking cycle will be needed. This should only be a small peck cycle of approx 0.1 mm.

A pecking cycle where the tool is removed out of the hole is not recommended. As a rule take increments of approx 10% of the drill diameter (e.g. 20 mm diameter = 2 mm peck depth).

**Tipp:**

If not yet at maximum feed rate potential, an increase in feed rate can lead to better chip breaking. If none of these changes are successful it may be necessary to insert a pecking cycle.

## SUGGERIMENTI PER ...

## ... corte e lunghezze standard SHARK-Drill®

Per una foratura senza problemi con punte seguire i seguenti accorgimenti:

- 1) Verificare e se possibile regolare la pressione del refrigerante (pag. 107).
- 2) Immediatamente dopo i primi millimetri di foro adattare i parametri di taglio. L'obiettivo è di ottenere un truciolo corto facilmente evacuabile dal foro.
- 3) Misurare il primo foro ed i fori seguenti per assicurarsi se la precisione è accettabile.
- 4) Durante la lavorazione assicurarsi sempre che il truciolo sia corto e che esca costantemente dal foro assieme al refrigerante. Nel caso di truciolo lungo prevedere un ciclo con stacchi per forzare la rottura truciolo.

**Scegliere sempre il corpo più corto possibile.**

Importante: Inserti in metallo duro integrale utilizzabili solo fino a circa  $6 - 7 \times D$ .

### Controllo truciolo

– I seguenti accorgimenti sono inoltre suggeriti:

- Controllare costantemente forma ed evacuazione truciolo.
- Qualora non sia ancora stato raggiunto il limite massimo consigliato, per un miglior controllo truciolo può essere utile aumentare l'avanzamento. Questo aiuta la rottura del truciolo.
- Se nessuno di questi cambiamenti porta ad un controllo truciolo, può essere indispensabile prevedere un ciclo con stacchi.

Per molti materiali, e specialmente per gli acciai della categoria inossidabili, può non essere sufficiente raggiungere il controllo truciolo solo modificando  $V_c$  ed  $f$ . In questi casi un ciclo con degli stacchi va previsto. Lo stacco non deve mai essere superiore a 0,1 mm. Prevedere un ciclo con la completa fuoriuscita del corpo punta dal foro non è raccomandato. Trucioli potrebbero interpersi tra tagliente e fondo del foro. Come regola generale considerare come partenza profondità di ogni ciclo pari a circa il 10% del diametro di foratura (Pes: 20 mm diametro = 2 mm profondità).

## SUGGERIMENTI PER ...

## ... corpi punta Lunghi (11 x D) ed Extra lunghi (14 x D) SHARK-Drill®

Per una foratura senza problemi con punte seguire i seguenti accorgimenti:

- 1) Punta pilota (circa 1 x D) con il medesimo diametro. L'angolo di punta deve essere uguale o maggiore dell'inserto SHARK-Drill®. Altre soluzioni:
  - Eseguire impronta conica con punte da centro ad angolo 132° (fino a Ø 65).
  - Eseguire impronta conica con punte da centro ad angolo 144° (da Ø 65 fino a Ø 114).
  - Ridurre avanzamenti (circa il 50% del parametro suggerito) fino a che l'intero diametro è in lavoro.

- 2) Aggiustare i parametri nei primi mm di foro per avere un miglior controllo delle condizioni di formazione del truciolo. Modificare i parametri ottimali come segue:

	8 – 11 x D	12 – 14 x D
$V_c$ [m/min]	0,9	0,58
$f$ [mm/U]	x	0,9

- 3) Controllare la pressione e la portata del refrigerante. La pressione del refrigerante (vedi pag. 107) va regolata seguendo la formula: SHARK-Drill® (8 – 11 x D) x 1,3 / (12 – 14 x D) x 1,5.
- 4) Misurare la prima parte del foro ed i primi fori per verificare se la tolleranza del foro è accettabili.
- 5) Aumentare i parametri di taglio fino ai valori prestabiliti e concludere la lavorazione assicurandosi di ottenere una gestione truciolo sicura. Prevedere eventuali cicli di stacco per aiutare la rottura del truciolo (mai oltre 0,1 mm).

**Scegliere sempre il corpo più corto possibile.**

Attenzione: Cuspidi in metallo duro sconsigliate.

### Controllo truciolo

– I seguenti accorgimenti sono inoltre suggeriti:

- Controllare costantemente forma ed evacuazione truciolo.
- Qualora non sia ancora stato raggiunto il limite massimo consigliato, per un miglior controllo truciolo può essere utile aumentare l'avanzamento. Questo aiuta la rottura del truciolo.
- Se nessuno di questi cambiamenti porta ad un controllo truciolo, può essere indispensabile prevedere un ciclo con stacchi.

Per molti materiali, e specialmente per gli acciai della categoria inossidabili, può non essere sufficiente raggiungere il controllo truciolo solo modificando  $V_c$  ed  $f$ . In questi casi un ciclo con degli stacchi va previsto. Lo stacco non deve mai essere superiore a 0,1 mm. Prevedere un ciclo con la completa fuoriuscita del corpo punta dal foro non è raccomandato. Trucioli potrebbero interpersi tra tagliente e fondo del foro. Come regola generale considerare come partenza profondità di ogni ciclo pari a circa il 10% del diametro di foratura (Pes: 20 mm diametro = 2 mm profondità).

## SUGGERIMENTI PER ...

## ... corpi punta Super Lunghi e Ultra Lunghi SHARK-Drill®

Per una foratura senza problemi con punte seguire i seguenti accorgimenti:

- 1) Foro pilota (approx.  $1 \times D - 2 \times D$ ) con il medesimo diametro. L'angolo di cuspidi del foro pilota deve essere uguale o maggiore di quello dell'inserto SHARK-Drill®. Altre soluzioni:
  - Eseguire impronta conica con punte da centro ad angolo  $132^\circ$  (fino a  $\varnothing 65$ ) – ridurre gli avanzamenti (circa 50% del valore suggerito) fino al raggiungimento dell'intero diametro.
  - Eseguire impronta conica con punte da centro ad angolo  $144^\circ$  (da  $\varnothing 65$  fino a  $\varnothing 114$ ) – ridurre gli avanzamenti (circa 50% del valore suggerito) fino a che l'intero diametro è in lavoro.
- 2) Ottenere i parametri ottimali di lavoro nei primi mm di foro. Solo così si potrà controllare visivamente la formazione del truciolo. Utilizzare sempre punte da centro specifiche per l'impronta e produrre trucioli più corti possibili per aiutare l'evacuazione.
- 3) Controllare la pressione e la portata del refrigerante. La pressione del refrigerante (vedi pag. 107) va regolata seguendo la formula: SHARK-Drill® ( $20 - 24 \times D$ )  $\times 2,0 / (25 - 32 \times D) \times 3,0$ .

- 4) Modificare i parametri ottimali come segue:

	20 – 24 x D	25 – 32 x D
$V_c$ [m/min]	0,80	0,75
$f$ [mm/U]	0,80	0,80

- 5) Per fori molto profondi prevedere l'uso di più corpi punta al fine di utilizzare parametri di taglio non ridotti dalla precedente formula. In questi casi prima che il corpo punta Super Lungo entri nel foro prevedere una rotazione massima di 10 – 20 giri/min. Le punte Super Lunghe e Ultra Lunghe possono raggiungere i parametri suggeriti solo quando l'inserto è in guida.
- 6) Aumentare i parametri di taglio fino ai valori prestabiliti e concludere la lavorazione assicurandosi di ottenere una gestione truciolo sicura. Prevedere eventuali cicli di stacco per aiutare la rottura del truciolo (mai oltre 0,1 mm).
- 7) Raggiunta la fine del foro arretrare mantenendo una rotazione di 10 – 20 giri/min.
- 8) Notare che i corpi punta di queste lunghezze flettono sollecitati al carico di punta.

### Controllo truciolo

– I seguenti accorgimenti sono inoltre suggeriti:

- Controllare costantemente forma ed evacuazione truciolo.
- Qualora non sia ancora stato raggiunto il limite massimo consigliato, per un miglior controllo truciolo può essere utile aumentare l'avanzamento. Questo aiuta la rottura del truciolo.
- Se nessuno di questi cambiamenti porta ad un controllo truciolo, può essere indispensabile prevedere un ciclo con stacchi.

Per molti materiali, e specialmente per gli acciai della categoria inossidabili, può non essere sufficiente raggiungere il controllo truciolo solo modificando  $V_c$  ed  $f$ . In questi casi un ciclo con degli stacchi va previsto. Lo stacco non deve mai essere superiore a 0,1 mm. Prevedere un ciclo con la completa fuoriuscita del corpo punta dal foro non è raccomandato. Trucioli potrebbero interpersi tra tagliente e fondo del foro. Come regola generale considerare come partenza profondità di ogni ciclo pari a circa il 10% del diametro di foratura (Pes: 20 mm diametro = 2 mm profondità).

## Schnittwerte-Multiplikator / Cutting data multiplier / Fattori di riduzione parametri

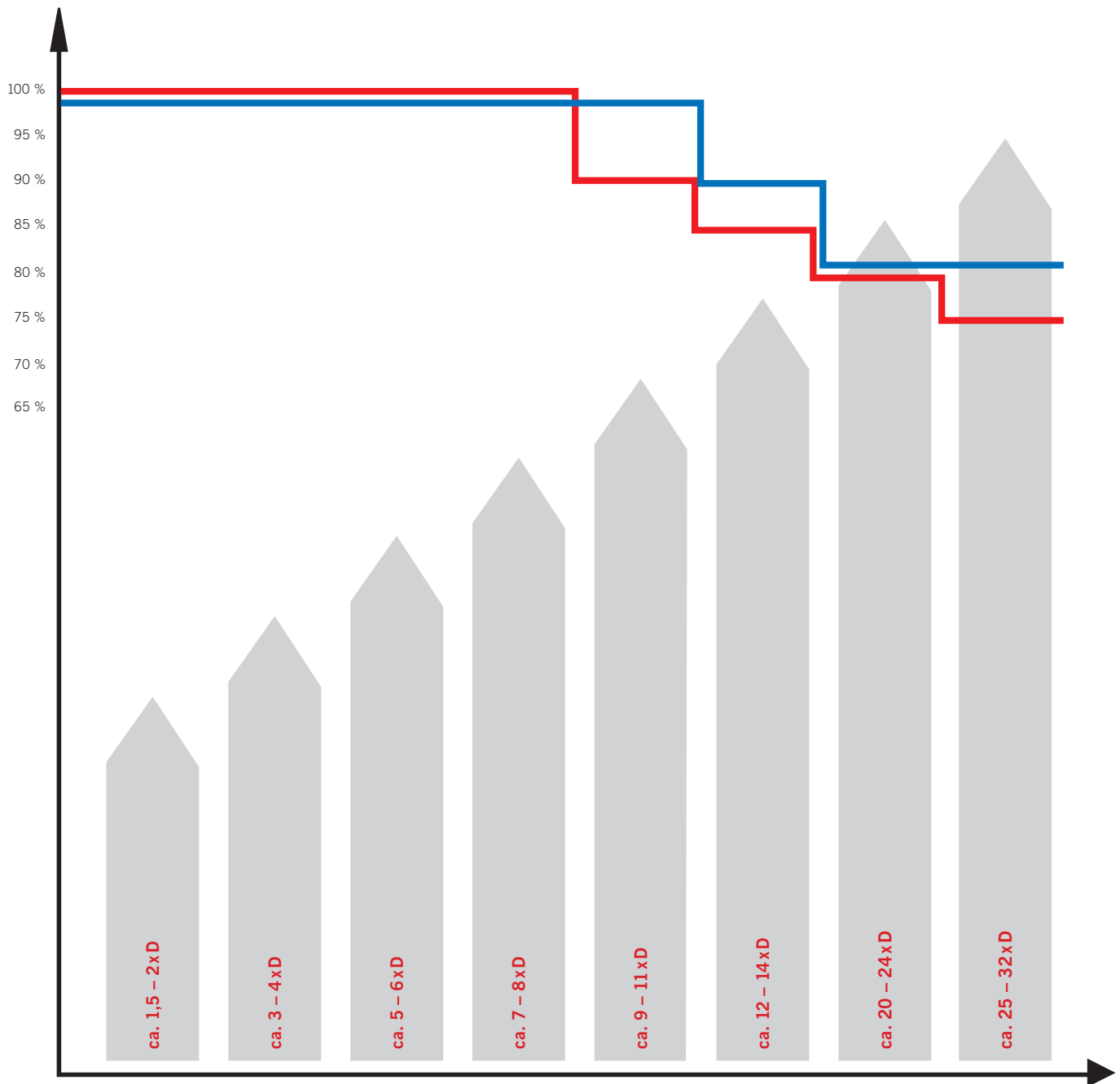

- **f** = **Vorschub** / Feed rate / Avanzamento
- **V<sub>c</sub>** = **Schnittgeschwindigkeit** / Cutting speed / Velocità di taglio

9 - 11xD	> V <sub>c</sub> x0,90
12 - 14xD	> V <sub>c</sub> x0,85; f x 0,90
20 - 24xD	> V <sub>c</sub> x0,80; f x 0,90
25 - 32xD	> V <sub>c</sub> x0,75; f x 0,80



## Für Flatschneidsätze / For flat bottom inserts / Per inserti a fondo piano -F

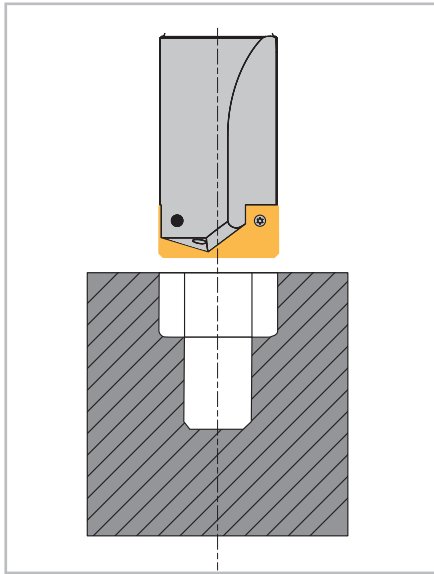

Die Flatschneidersätze sind ausschließlich in HSS5 lieferbar. Eingesetzt werden sie bei der Bohrungsgrundbearbeitung (z. B. für Schraubensenkungen). Es empfiehlt sich maximal Halter der Standardlänge zu verwenden.

*The Flat Bottom Inserts are available in grade HSS5 only. The basic application is to drill the bottom of a hole (e.g. for screw countersinks). It is advisable to use holders of the standard length only.*

Gli per fori a fondo piano sono disponibili nel grado HSS5. La principale applicazione di tali inserti è per la esecuzione del piano sul fondo di fori già eseguiti o per lamature poco profonde (alloggiamento testa vite). E'consigliabile usare corpi più corti possibile.

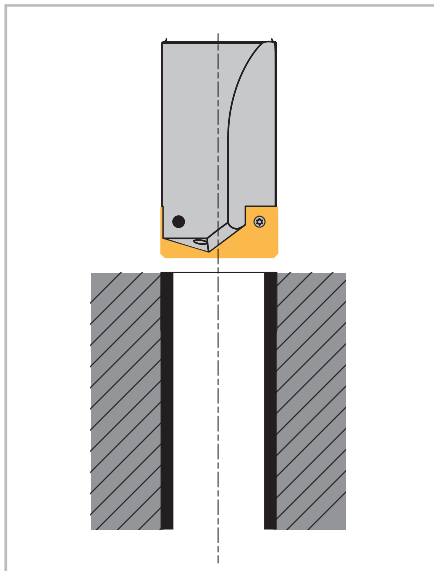

Bei der Verwendung zum Aufbohren sollten maximal mittellange Halter verwendet werden. Es ist außerdem darauf zu achten, dass der Durchmesserunterschied (Vorbohrdurchmesser zu Aufbohrdurchmesser) größer als die Eckenschutzfase ist. Die Flucht der aufgebohrten Bohrung entspricht der Flucht der Vorbohrung.

*If counterboring only up to intermediate length holders should be used. It is necessary that the difference between the pre-existing hole and the counterbore diameter is bigger than the size of the cornerclips of the insert. The lead is nearly the same than the pre-existing hole.*

Nell'utilizzo come barenatura di fori utilizzare corpi punta molto corti. Per un corretto funzionamento fare in modo che il sovrametallo superi la dimensione dello smusso sul tagliente dell'inserto. La rettilineità ottenuta è identica al preforo eseguito.

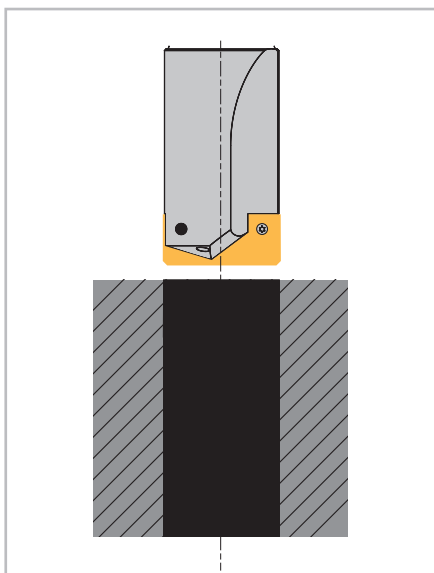

Ins Volle zu bohren funktioniert mit Abstrichen ausschließlich bei einfach zu zerspanenden Werkstoffen wie Aluminium oder Automatenstahl. Der Einsatz wird nur in Verbindung mit kurzen Haltern empfohlen.

*To drill into solid it is only possible with limitations and easy to machine workpiece materials (e.g. aluminum and free machining steel). Short length holders should only be used.*

L'esecuzione di fori dal pieno è possibile solo per materiali facili da lavorare (alluminio, acciaio non legato). Utilizzare sempre corpi extra corti.

Additional coolant for mose taper shank  
 Fori addizionali per attacchi cono morse

## Erweiterte DIN 228 Form BK / Extended DIN 228 form BK / Estensione DIN 228 forma BK

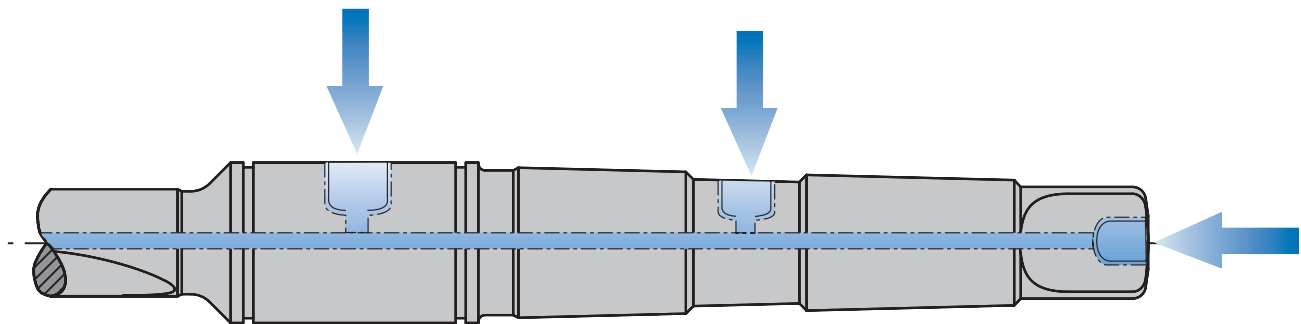

1

Es bestehen 3 Kühlmitteloptionen:

- seitlich über den drehend gelagerten Kühlmittelring
- von hinten durch den Austreiblappen
- in der Mitte des Morsekegels

Im Auslieferungszustand ist das hintere Gewinde am Austreiblappen und das Gewinde am Kühlmittelringsitz durch Verschlusschrauben mit Innensechskant verschlossen. Je nach gewünschter Kühlmitteloption an der Maschine können Sie entsprechend den Kühlmittelfluss bestimmen.

Three coolant options available:

- form the side with coolant ring
- through the shank
- through the morse taper

At first delivery, the tool is set up with a hexagon socket screw for coolant option "through tang". A second screw close the thread at the rotary coolant ring. According to machine requirements select the coolant supply.

Tre opzioni di refrigerante disponibili:

- dal lato con anello refrigerante
- attraverso il corpo
- dal lato del cono

Alla consegna, l'utensile viene fornito per l'uso "attraverso il corpo". Un grano chiude il passaggio per l'anello refrigerante ed un secondo grano chiude il passaggio dal cono. I grani possono venire spostati per l'uso richiesto.

## Optional mit DIN ISO 9766-Schaft (-W) und rückseitigem Gewinde nach BSP ISO 7-1

Optional with DIN ISO 9766 shank (-W) for threaded coolant connection to BSP ISO 7-1

Versione corpi (-W) con foro filettato BSP ISO 7-1

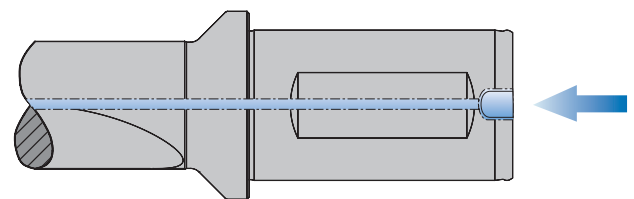

**Verschleißfestigkeit und Zähigkeit**

*Wear resistance and Toughness*  
Resistenza all'usura e Tenacità

**Hartmetall ist gegenüber den HSS-Sorten sehr verschleißfest, zugleich aber auch bruchempfindlich (siehe Abb.). Daher empfehlen wir den Einsatz von Hartmetallen nur unter stabilen Schnittbedingungen (kurze Bohrtiefen, stabile Spannung, gute Spannbildung).**

*As you can see, carbide against HSS-grades are very wear resistant, but also brittle. We recommend the use of carbide only under stable cutting conditions (short drill depths, rigid clamping, good chip formation).*

Come si può notare I metalli duri rispetto agli HSS hanno molta più resistenza all'usura ma sono più fragili. Si raccomanda l'utilizzo die metalli duri solamente in abbinamento a stabili condizioni di lavorazione (fori corti, fissaggi rigidi, buona formazione di truciolo).

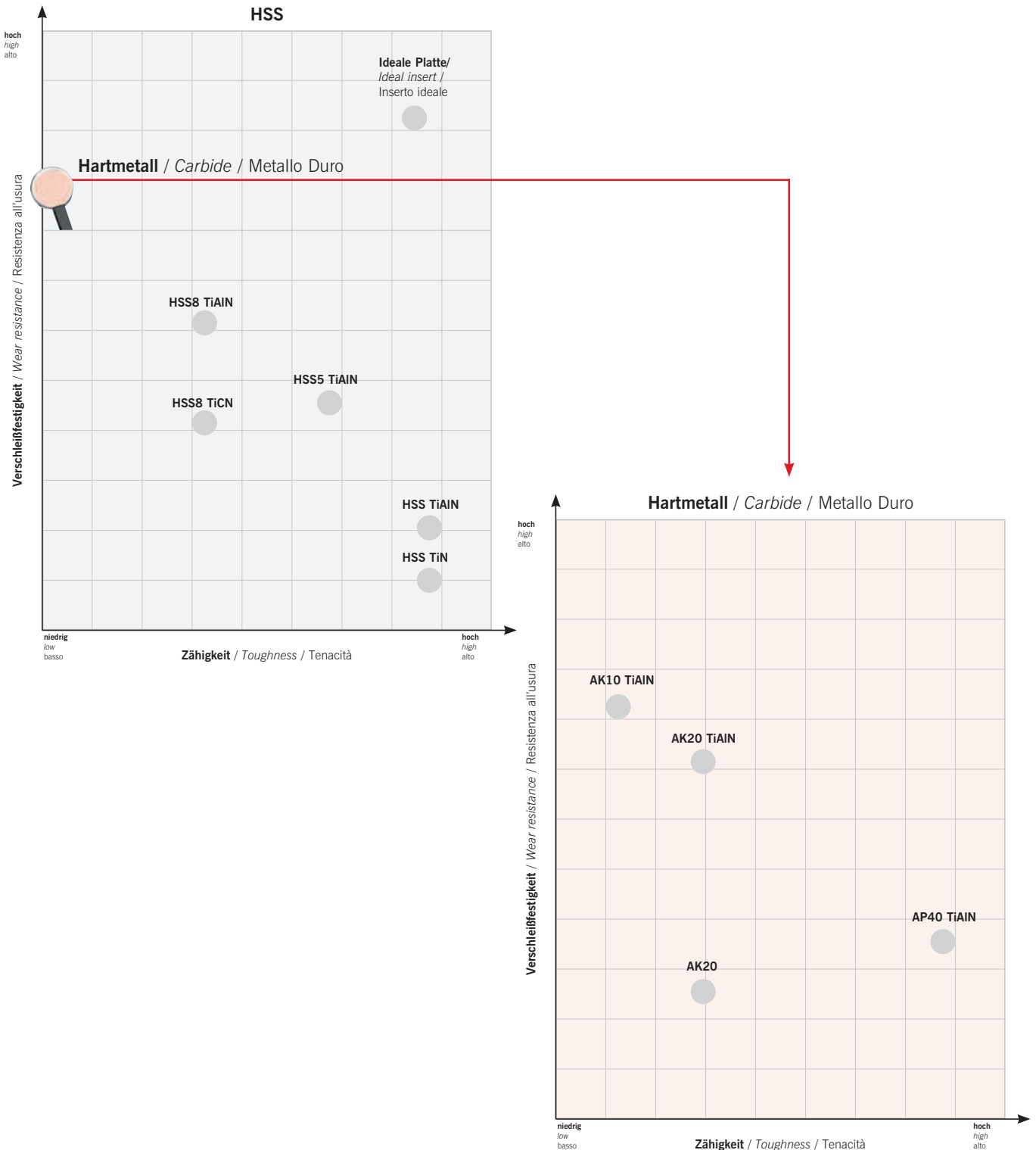

## Langjährige Erfahrung

Im Bereich der Sonderwerkzeuge greift ARNO-Werkzeuge auf einen langjährigen Erfahrungsschatz zurück. Viele Unternehmen fertigen mit ARNO-Werkzeuge wesentlich effektiver und kostengünstiger. Ob es sich um Sonderbohrplatten oder komplexe Kombi-Bohrwerkzeuge handelt, speziell gefertigte Sonderwerkzeuge – kundenspezifisch entwickelt, flexibel, schnell und kostengünstig gefertigt – das steht für unsere zeitgemäße Fertigung.

## Many years of experience

ARNO-Werkzeuge is using its many years of experience and expertise in special tooling. Many customers have improved efficiency using special inserts, complex combination tools or specific drilling tools. Our promise is fast, flexible and economical special solutions that work.

## Tanti anni di esperienza

ARNO-Werkzeuge mette a disposizione i tanti anni di esperienza e perizia nella costruzione di utensili speciali. Molti die nostri clienti hanno migliorato la loro efficienza tramite l'utilizzo di inserti speciali, complessi utensili combinati o specifici utensili di foratura. La nostra promessa è una veloce, flessibile ed economica soluzione speciale per la vostra applicazione.

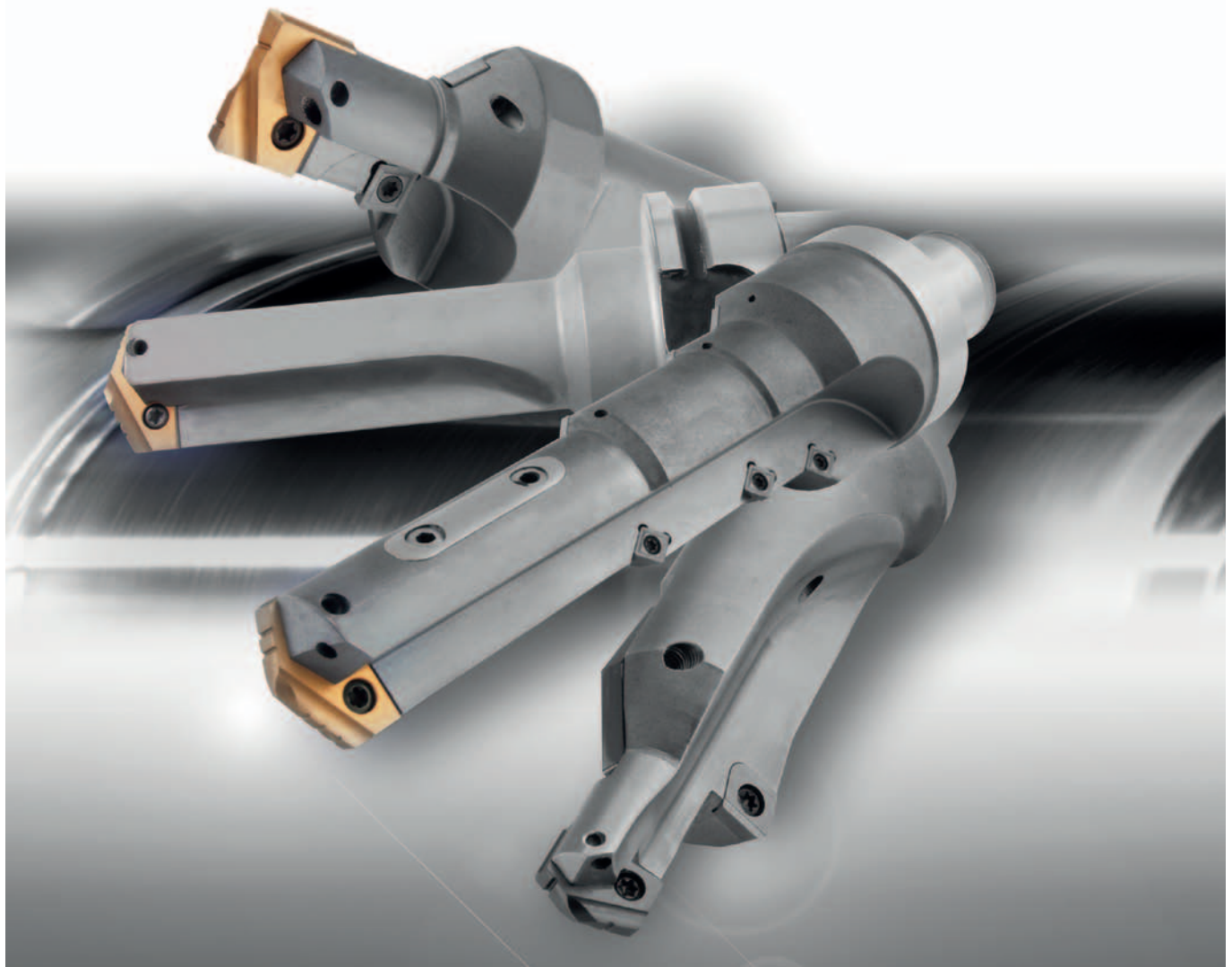

Für Fragen stehen wir Ihnen gerne zur Verfügung. Wir unterbreiten Ihnen ein individuelles Angebot ganz nach Ihren Anforderungen.

If you have any questions, please do not hesitate to contact us. We would be pleased to quote according to your specifications.

Per qualsiasi esigenza non esitate a contattarci. Vi preghiamo di chiamarci anche per un preventivo personalizzato in base alle vostre esigenze.

Karl-Heinz Arnold GmbH  
Karlsbader Str. 4  
D-73760 Ostfildern

☎: +49 (0)711 34 802 0  
☎: +49 (0)711 34 802 130  
info@arno.de  
www.arno.de

ARNO (UK) Limited  
Business Centre | Sugnall, Eccleshall  
Staffordshire | ST21 6NF

☎: +44 01785 850 072  
☎: +44 01785 850 076  
sales@arno.de  
www.arno-tools.co.uk

ARNO Italia S.r.l.  
Via J. F. Kennedy 19  
20871 Vimercate (MB)

☎: +39 039 68 52 101  
☎: +39 039 60 83 724  
info@arno-italia.it  
www.arno-italia.it