



SHARK-Cut®

- Systemvorstellung
- Bezeichnungssystem
- Werkzeugauswahl
- SHARK-Cut® Mini
- SHARK-Cut® Standard
- SHARK-Cut® Rebore
- Wendeschneidplatten
 - Geometriebeschreibung
 - Sortenbeschreibung
- Ersatzteile
- Schnittwerte
- Anwendungshinweise

SHARK-Cut®

- *Introduction*
- *Designation system*
- *Tool shank options*
- *SHARK-Cut® Mini*
- *SHARK-Cut® Standard*
- *SHARK-Cut® Rebore*
- *Inserts*
 - *Geometry description*
 - *Grade description*
- *Spare parts*
- *Cutting data*
- *Application reference*

SHARK-Cut®

- Caratteristiche del sistema
- Sistema di numerazione
- Tipologie di numerazione
- SHARK-Cut® Mini
- SHARK-Cut® Standard
- SHARK-Cut® Rebore
- Inserti
 - Descrizione delle Geometrie
 - Descrizione delle Qualità
- Ricambi
- Parametri di taglio
- Suggerimenti tecnici

168 – 169
170
171
172
173 – 175
176 – 177
178 – 182
178
179 – 180
183 – 184
185 – 192
193 – 198

ARNO Multifunktionswerkzeug SHARK-Cut®

ARNO Multi purpose tool SHARK-Cut®

ARNO Utensile multifunzione SHARK-Cut®

Vorteile des SHARK-CUT®-Systems:

DREHEN und BOHREN mit nur 1 Werkzeug!

Advantages of the Shark-Cut® system:

Turning and boring with only 1 tool!

Vantaggi del sistema SHARK-Cut®:

Foratura e barenatura con un unico utensile!

- Erzeugt ebenen Bohrungsgrund
- Problemlöser bei fehlenden Werkzeugplätzen an der Maschine
- Weniger Programmieraufwand
- Kürzere Rüstzeiten
- Reduzierte Voreinstellzeiten
- Reduzierte Lagerhaltung von Werkzeugen und Wendschneidplatten
- Geringere Kosten für die Werkzeugbeschaffung
- Produces a flat bottom hole
- Problem solver for insufficient machine tool posts
- Less programming
- Shorter set-up times
- Reduced pre-setting times
- Reduced stock-keeping costs for tools and indexable inserts
- Lower tool purchasing costs
- Foratura con fondo piano
- Risolutore di problemi nei casi di limitate posizioni utensili
- Riduce la programmazione macchina
- Riduce i tempi di setup utensili
- Riduce i tempi di setup
- Riduce i costi di magazzino di utensili ed inserti
- Riduce i costi di utensileria

4

SHARK-CUT® Mini:

DREHEN und BOHREN $\geq \varnothing 4 \text{ mm}$

Vollhartmetallwerkzeug

Turning and boring $\geq \varnothing 4 \text{ mm}$

Solid carbide tool

Foratura e barenatura $\geq \varnothing 4 \text{ mm}$

Utensile in metallo duro integrale

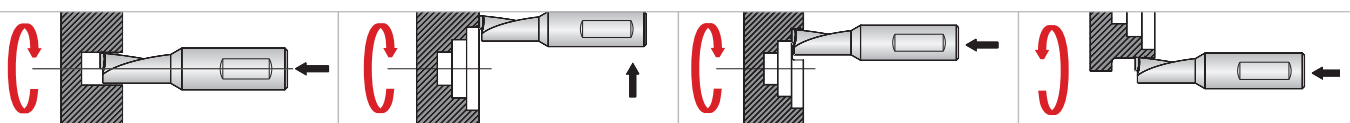

Bohren ins Volle mit ebenem Bohrungsgrund
Drilling with flat bottom face
Foratura con fondo piano

Drehen von Plankonturen
Facing operations
Sfacciatura

Drehen von Innenkonturen
Turning of internal profiles
Tornitura interna con ap ad inserto pieno

Drehen von Außenkonturen
Turning of external profiles
Tornitura esterna

SHARK-CUT® Standard:**DREHEN und BOHREN $\geq \varnothing 8$ mm***Turning and boring $\geq \varnothing 8$ mm*Foratura e barenatura $\geq \varnothing 8$ mm

1,5 x D

2,25 x D

3 x D

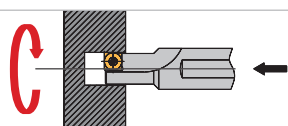

**Bohren ins Volle mit ebenem
Bohrungsgrund**
Drilling with flat bottom face
Foratura con fondo piano

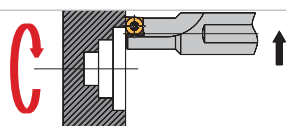

Drehen von Plankonturen
Facing operations
Sfacciatura

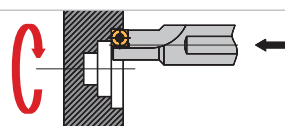

Drehen von Innenkonturen
Turning of internal profiles
Tornitura interna con ap ad
inserto pieno

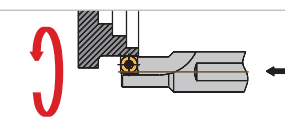

Drehen von Außenkonturen
Turning of external profiles
Tornitura esterna

SHARK-CUT® Rebore:**2-schneidig $\geq \varnothing 12$ mm***2 flute $\geq \varnothing 12$ mm*2 taglienti $\geq \varnothing 12$ mm

2,25 x D

3-schneidig $\geq \varnothing 24$ mm*3 flute $\geq \varnothing 24$ mm*3 taglienti $\geq \varnothing 24$ mm

2,25 x D

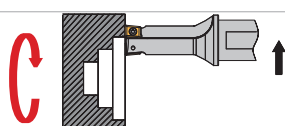

Drehen von Plankonturen
Facing operations
Sfacciatura

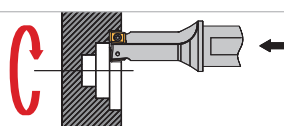

Drehen von Innenkonturen
Turning of internal profiles
Tornitura interna con ap ad
inserto pieno

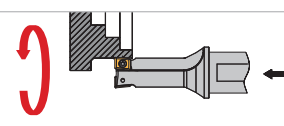

Drehen von Außenkonturen
Turning of external profiles
Tornitura esterna

Designation system
Sistema di numerazione

SHARK-CUT® Mini

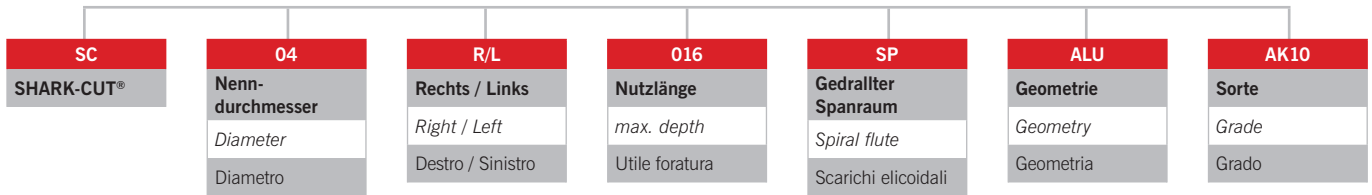

SHARK-CUT® Standard

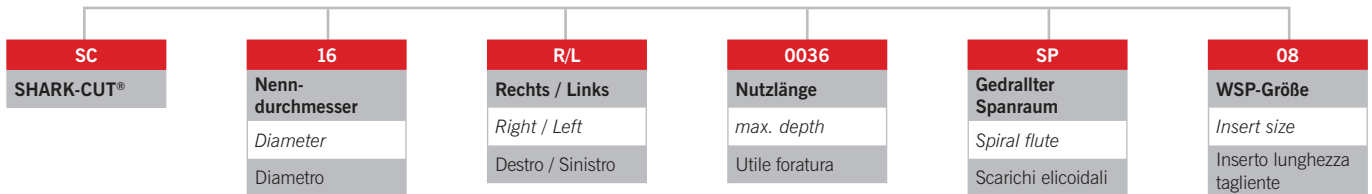

SHARK-CUT® Rebore

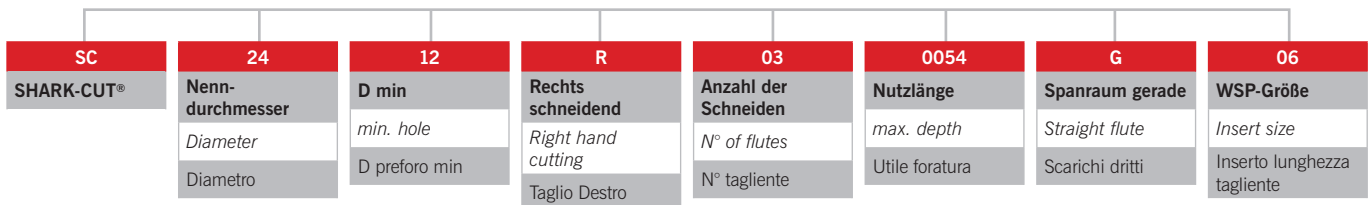

SHARK-CUT® Wendeschneidplatten / Inserts / Inserti

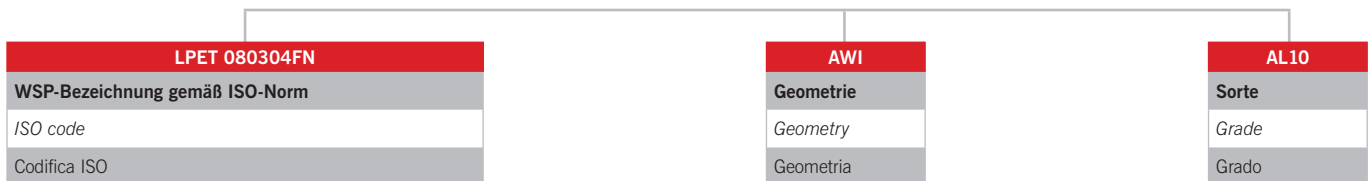

4



SHARK-CUT® **Mini**

2,25 x D	Ø 4,0 – 8,0 mm	172
4 x D	Ø 4,0 – 8,0 mm	172



SHARK-CUT® **Standard**

1,5 x D	Ø 8,0 – 32,0 mm	173
2,25 x D	Ø 8,0 – 32,0 mm	174
3 x D	Ø 8,0 – 32,0 mm	175
	Densimet	



SHARK-CUT® **Rebore**

2-schneidig / 2 flute / 2 taglienti		
2,25 x D	Ø 12,0 – 50,0 mm	176
3-schneidig / 3 flute / 3 taglienti		
2,25 x D	Ø 24,0 – 50,0 mm	177

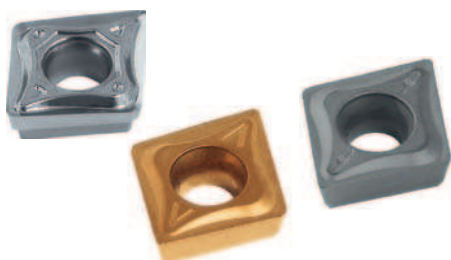

SHARK-CUT® **Wendeschneidplatten**

Inserts
Inserti

LPET	181
LPNT	182

Solid carbide cutter
Utensile in Metallo Duro

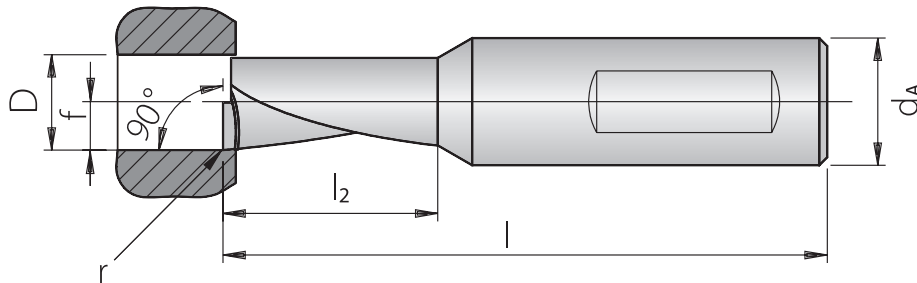

Schneideinsatz / Insert / Inserto

Rechte Ausführung abgebildet
Right-hand execution shown
Versione Destra in figura

Bezeichnung Designation Articolo	D	l	l ₂	d _A	f	r	beschichtet coated rivestito		unbeschichtet uncoated non rivestito	
							AL350	AM35C	AK10	AP40
SC04R/L-009SP	4	35	9,00	6	2,0	0,2	●			
SC04R/L-009SP-ALU	4	35	9,00	6	2,0	0,2			●	
SC04R/L-016SP	4	41	16,00	6	2,0	0,2	●			
SC04R/L-016SP-ALU	4	41	16,00	6	2,0	0,2			●	
SC05R/L-011SP	5	37	11,25	6	2,5	0,2	●			
SC05R/L-011SP-ALU	5	37	11,25	6	2,5	0,2			●	
SC05R/L-020SP	5	45	20,00	6	2,5	0,2	●			
SC05R/L-020SP-ALU	5	45	20,00	6	2,5	0,2			●	
SC06R/L-013SP	6	38	13,50	8	3,0	0,2	●			
SC06R/L-013SP-ALU	6	38	13,50	8	3,0	0,2			●	
SC06R/L-024SP	6	49	24,00	8	3,0	0,2	●			
SC06R/L-024SP-ALU	6	49	24,00	8	3,0	0,2			●	
SC07R/L-015SP	7	42	15,75	8	3,5	0,2	●			
SC07R/L-015SP-ALU	7	42	15,75	8	3,5	0,2			●	
SC07R/L-028SP	7	53	28,00	8	3,5	0,2	●			
SC07R/L-028SP-ALU	7	53	28,00	8	3,5	0,2			●	
SC08R/L-018SP	8	45	18,00	8	4,0	0,2	●			
SC08R/L-018SP-ALU	8	45	18,00	8	4,0	0,2			●	
SC08R/L-032SP	8	57	32,00	8	4,0	0,2	●			
SC08R/L-032SP-ALU	8	57	32,00	8	4,0	0,2			●	

4

Adapter / Holder / Adattatore

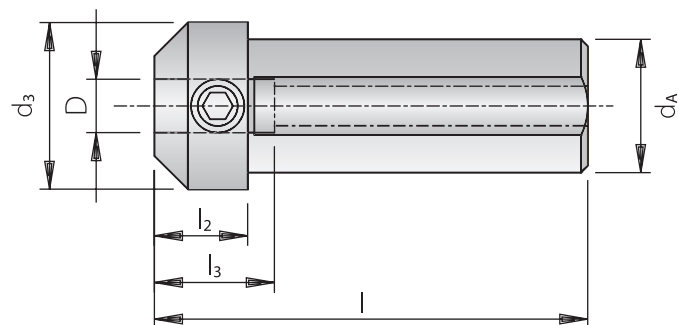

Trägerwerkzeug / Holder / Utensile

Bezeichnung Designation Articolo	D	d ₃	l	l ₂	l ₃	d _A	Klemmschraube Clambingscrew Vite
SC AD20-06	6	25	65	14	18	20	7897990
SC AD20-08	8	25	65	14	18	20	7897990

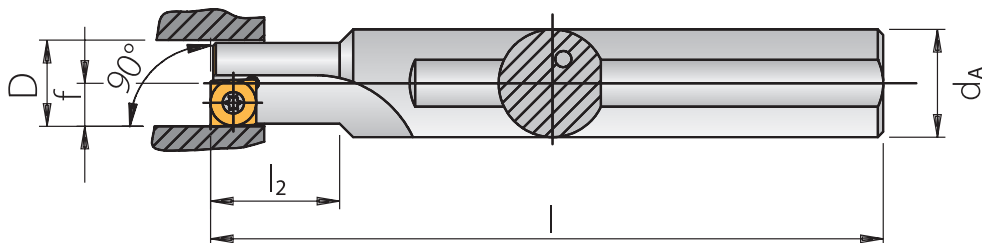
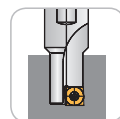
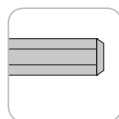

Trägerwerkzeug / Holder / Utensile

Rechte Ausführung abgebildet

Right-hand execution shown

Versione Destra in figura

Bezeichnung Designation Articolo	D	l	l ₂	d _A	f	Wendeschneidplatte Insert Inserto
SC08R/L-0012G-04*	8	80	12,0	12	4,0	LPET / LPNT 0401..
SC10R/L-0015G-05	10	90	15,0	12	5,0	LPET / LPNT 0502..
SC12R/L-0018G-06	12	100	18,0	16	6,0	LPET / LPNT 0602..
SC14R/L-0021G-07	14	110	21,0	16	7,0	LPET / LPNT 0703..
SC16R/L-0024G-08	16	125	24,0	20	8,0	LPET / LPNT 0803..
SC18R/L-0027G-09	18	135	27,0	25	9,0	LPET / LPNT 09T3..
SC20R/L-0030G-10	20	150	30,0	25	10,0	LPET / LPNT 10T3..
SC25R/L-0038G-13	25	180	37,5	32	12,5	LPET / LPNT 1304..
SC32R/L-0048G-17	32	200	48,0	40	16,0	LPET / LPNT 1705..

* Rechter Halter → Rechte Wendeschneidplatte

Linker Halter → Linke Wendeschneidplatte

* Right-hand holder → Right-hand indexable insert

Left-hand holder → Left-hand indexable insert

* Utensile Destro → Inserto Destro

Utensile Sinistro → Inserto Sinistro

HINWEIS:

Trägerwerkzeuge werden mit Klemmschrauben und Ersatzschrauben geliefert, jedoch ohne Schlüssel.

Ersatzteile und Zubehör siehe Seite 183.

INFORMATION: Holders will be supplied with clamping screws and spare screws, however without key. Spare parts and accessories see page 183.

NOTA:

L'utensile é fornito completo di vite, 1 vite di ricambio, ma SENZA chiave. Ricambi a pagina 183.

Drilling depth up to 2.25 x D
Foratura fino a 2,25 x D

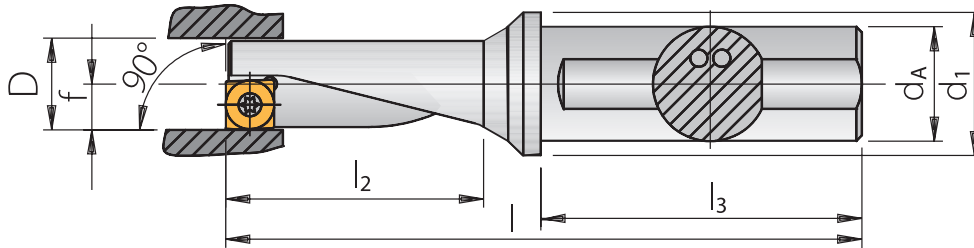
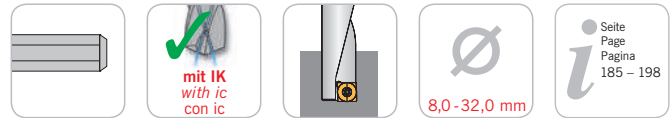

2,25
xD

Trägerwerkzeug / Holder / Utensile

Rechte Ausführung abgebildet
Right-hand execution shown
Versione Destra in figura

Bezeichnung Designation Articolo	D	l	l ₂	l ₃	d ₁	d _A	f	Wendeschneidplatte Insert Inserto
SC08R/L-0018SP-04*	8	60,0	18,0	38	12	10	4,0	LPET / LPNT 0401..
SC10R/L-0023SP-05	10	69,5	22,5	42	16	12	5,0	LPET / LPNT 0502..
SC12R/L-0027SP-06	12	78,0	27,0	45	20	16	6,0	LPET / LPNT 0602..
SC14R/L-0032SP-07	14	83,5	31,5	45	20	16	7,0	LPET / LPNT 0703..
SC16R/L-0036SP-08	16	94,0	36,0	50	25	20	8,0	LPET / LPNT 0803..
SC18R/L-0041SP-09	18	109,5	40,5	56	32	25	9,0	LPET / LPNT 09T3..
SC20R/L-0045SP-10	20	111,0	45,0	56	32	25	10,0	LPET / LPNT 10T3..
SC25R/L-0057SP-13	25	129,0	56,5	60	40	32	12,5	LPET / LPNT 1304..
SC32R/L-0072SP-17	32	158,0	72,0	70	50	40	16,0	LPET / LPNT 1705..

* Rechter Halter → Rechte Wendeschneidplatte
Linker Halter → Linke Wendeschneidplatte

* Right-hand holder → Right-hand indexable insert
Left-hand holder → Left-hand indexable insert

* Utensile Destro → Inserto Destro
Utensile Sinistro → Inserto Sinistro

HINWEIS: Trägerwerkzeuge werden mit Klemmschrauben und Ersatzschrauben geliefert, jedoch ohne Schlüssel.
Ersatzteile und Zubehör siehe Seite 183.

INFORMATION: Holders will be supplied with clamping screws and spare screws, however without key. Spare parts and accessories see page 183.

NOTA: L'utensile é fornito completo di vite, 1 vite di ricambio, ma SENZA chiave. Ricambi a pagina 183.

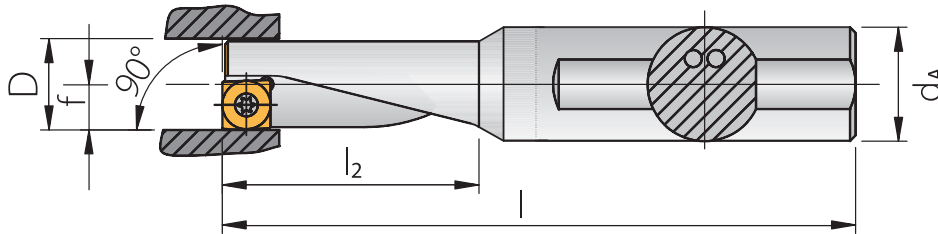
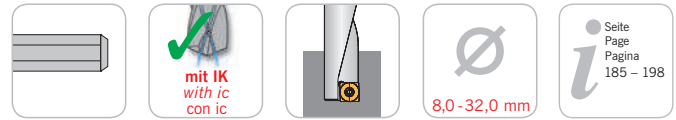

Schwingungsarm!
Vibration damped!
Stop alle vibrazioni!



Trägerwerkzeug / Holder / Utensile

Rechte Ausführung abgebildet
Right-hand execution shown
Versione Destra in figura

Bezeichnung Designation Articolo	D	l	l ₂	d _A	f	Wendeschneidplatte Insert Inserto
SC08R/L-0024SP-04*	8	80	24	12	4,0	LPET / LPNT 0401..
SC10R/L-0030SP-05	10	85	30	12	5,0	LPET / LPNT 0502..
SC12R/L-0036SP-06	12	95	36	16	6,0	LPET / LPNT 0602..
SC14R/L-0042SP-07	14	100	42	16	7,0	LPET / LPNT 0703..
SC16R/L-0048SP-08	16	110	48	20	8,0	LPET / LPNT 0803..
SC18R/L-0054SP-09	18	125	54	25	9,0	LPET / LPNT 09T3..
SC20R/L-0060SP-10	20	130	60	25	10,0	LPET / LPNT 10T3..
SC25R/L-0075SP-13	25	150	75	32	12,5	LPET / LPNT 1304..
SC32R/L-0096SP-17	32	185	96	40	16,0	LPET / LPNT 1705..

* Rechter Halter → Rechte Wendeschneidplatte
Linker Halter → Linke Wendeschneidplatte

* Right-hand holder → Right-hand indexable insert
Left-hand holder → Left-hand indexable insert

* Utensile Destro → Inserto Destro
Utensile Sinistro → Inserto Sinistro

HINWEIS: Trägerwerkzeuge werden mit Klemmschrauben und Ersatzschrauben geliefert, jedoch ohne Schlüssel.
Ersatzteile und Zubehör siehe Seite 183.

INFORMATION: Holders will be supplied with clamping screws and spare screws, however without key. Spare parts and accessories see page 183.

NOTA: L'utensile é fornito completo di vite, 1 vite di ricambio, ma SENZA chiave. Ricambi a pagina 183.

Drilling depth up to 2.25 x D – 2 flute
Foratura fino a 2,25 x D – 2 taglienti

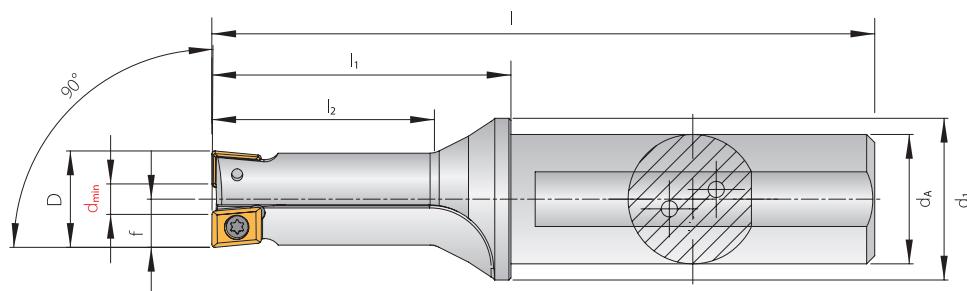

Trägerwerkzeug / Holder / Utensile

Rechte Ausführung abgebildet
Right-hand execution shown
Versione Destra in figura

Bezeichnung Designation Articolo	D	d _{min}	l	l ₁	l ₂	d ₁	d _A	f	z	Wendeschneidplatte Insert Inserto
SCR1204R02-0027G-04*	12,0	4,0	82	37	27	20	16	5,0	2	LPET / LPNT 0401..
SCR1305R02-0029G-04*	13,0	5,0	84	39	29	20	16	6,0	2	LPET / LPNT 0401..
SCR1406R02-0032G-04*	14,0	6,0	86	41	32	20	16	7,0	2	LPET / LPNT 0401..
SCR1507R02-0034G-04*	15,0	7,0	88	43	34	20	16	8,0	2	LPET / LPNT 0401..
SCR1606R02-0036G-05	16,0	6,0	97	47	36	25	20	7,0	2	LPET / LPNT 0502..
SCR1707R02-0038G-05	17,0	7,0	99	49	38	25	20	8,0	2	LPET / LPNT 0502..
SCR17575R02-0039G-05	17,5	7,5	101	51	39	25	20	8,5	2	LPET / LPNT 0502..
SCR1806R02-0041G-06	18,0	6,0	102	52	41	25	20	7,0	2	LPET / LPNT 0602..
SCR1907R02-0043G-06	19,0	7,0	104	54	43	25	20	8,0	2	LPET / LPNT 0602..
SCR2006R02-0045G-07	20,0	6,0	114	58	45	32	25	7,0	2	LPET / LPNT 0703..
SCR2107R02-0047G-07	21,0	7,0	116	60	47	32	25	8,0	2	LPET / LPNT 0703..
SCR2208R02-0050G-07	22,0	8,0	118	62	50	32	25	9,0	2	LPET / LPNT 0703..
SCR2309R02-0052G-07	23,0	9,0	120	64	52	32	25	10,0	2	LPET / LPNT 0703..
SCR2408R02-0054G-08	24,0	8,0	122	66	54	32	25	9,0	2	LPET / LPNT 0803..
SCR2509R02-0056G-08	25,0	9,0	130	70	56	40	32	10,0	2	LPET / LPNT 0803..
SCR2608R02-0059G-09	26,0	8,0	134	74	59	40	32	9,0	2	LPET / LPNT 09T3..
SCR2709R02-0061G-09	27,0	9,0	137	77	61	40	32	10,0	2	LPET / LPNT 09T3..
SCR2810R02-0063G-09	28,0	10,0	140	80	63	40	32	11,0	2	LPET / LPNT 09T3..
SCR2909R02-0065G-10	29,0	9,0	144	84	65	40	32	10,0	2	LPET / LPNT 10T3..
SCR3010R02-0068G-10	30,0	10,0	146	86	68	40	32	11,0	2	LPET / LPNT 10T3..
SCR3111R02-0070G-10	31,0	11,0	149	89	70	40	32	12,0	2	LPET / LPNT 10T3..
SCR3212R02-0072G-10	32,0	12,0	151	91	72	40	32	13,0	2	LPET / LPNT 10T3..
SCR3313R02-0074G-10	33,0	13,0	154	94	75	40	32	13,0	2	LPET / LPNT 10T3..
SCR3414R02-0077G-10	34,0	14,0	156	96	77	40	32	15,0	2	LPET / LPNT 1304..
SCR3510R02-0079G-13	35,0	10,0	166	96	79	50	40	10,0	2	LPET / LPNT 1304..
SCR3611R02-0081G-13	36,0	11,0	168	98	81	50	40	11,0	2	LPET / LPNT 1304..
SCR3712R02-0083G-13	37,0	12,0	170	100	83	50	40	12,0	2	LPET / LPNT 1304..
SCR3813R02-0086G-13	38,0	13,0	173	103	86	50	40	13,0	2	LPET / LPNT 1304..
SCR3914R02-0088G-13	39,0	14,0	175	105	88	50	40	14,0	2	LPET / LPNT 1304..
SCR4015R02-0090G-13	40,0	15,0	177	107	90	50	40	15,0	2	LPET / LPNT 1304..
SCR4116R02-0092G-13	41,0	16,0	179	109	92	50	40	16,0	2	LPET / LPNT 1304..
SCR4217R02-0095G-13	42,0	17,0	182	112	95	50	40	17,0	2	LPET / LPNT 1304..
SCR4318R02-0097G-13	43,0	18,0	185	115	97	50	40	18,0	2	LPET / LPNT 1304..
SCR4419R02-0099G-13	44,0	19,0	187	117	99	50	40	19,0	2	LPET / LPNT 1304..
SCR4513R02-0101G-17	45,0	13,0	192	122	101	55	40	13,0	2	LPET / LPNT 1705..
SCR4614R02-0104G-17	46,0	14,0	194	124	104	55	40	14,0	2	LPET / LPNT 1705..
SCR4715R02-0106G-17	47,0	15,0	196	126	106	55	40	15,0	2	LPET / LPNT 1705..
SCR4816R02-0108G-17	48,0	16,0	198	128	108	55	40	16,0	2	LPET / LPNT 1705..
SCR4917R02-0110G-17	49,0	17,0	200	130	110	55	40	17,0	2	LPET / LPNT 1705..
SCR5018R02-0113G-17	50,0	18,0	203	133	113	55	40	18,0	2	LPET / LPNT 1705..

* Rechter Halter → Rechte Wendeschneidplatte

* Right-hand holder → Right-hand indexable insert

* Utensile Destro → Inserto Destro

HINWEIS: Trägerwerkzeuge werden mit Klemmschrauben und Ersatzschrauben geliefert, jedoch ohne Schlüssel. Ersatzteile und Zubehör siehe Seite 183.

INFORMATION: Holders will be supplied with clamping screws and spare screws, however without key. Spare parts and accessories see page 183.

NOTA: L'utensile é fornito completo di vite, 1 vite di ricambio, ma SENZA chiave. Ricambi a pagina 183.

Drilling depth up to 2.25 x D – 3 flute
Foratura fino a 2,25 x D – 3 taglienti

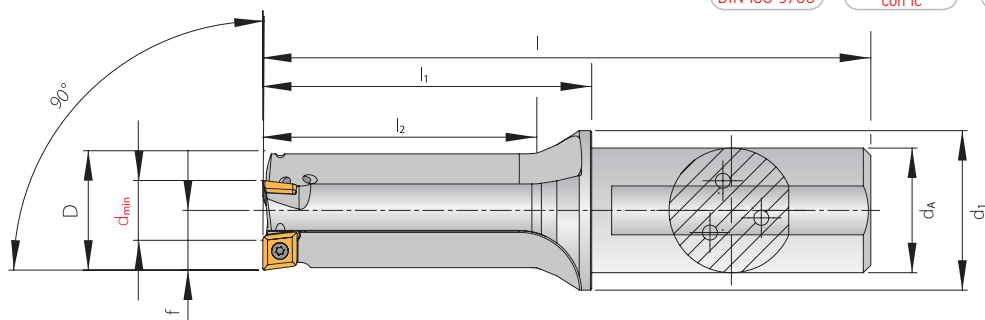
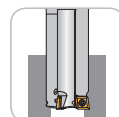

Trägerwerkzeug / Holder / Utensile

Rechte Ausführung abgebildet
Right-hand execution shown
Versione Destra in figura

Bezeichnung Designation Articolo	D	d _{min}	l	l ₁	l ₂	d ₁	d _A	f	z	Wendeschneidplatte Insert Inserto
SCR2412R03-0054G-06	24	12	122	66	54	32	25	13	3	LPET / LPNT 0602..
SCR2513R03-0056G-06	25	13	130	70	56	40	32	14	3	LPET / LPNT 0602..
SCR2612R03-0059G-07	26	12	134	74	59	40	32	13	3	LPET / LPNT 0703..
SCR2713R03-0061G-07	27	13	137	77	61	40	32	14	3	LPET / LPNT 0703..
SCR2814R03-0063G-07	28	14	140	80	63	40	32	15	3	LPET / LPNT 0703..
SCR2913R03-0065G-08	29	13	144	84	65	40	32	14	3	LPET / LPNT 0803..
SCR3014R03-0068G-08	30	14	146	86	68	40	32	15	3	LPET / LPNT 0803..
SCR3115R03-0070G-08	31	15	149	89	70	40	32	16	3	LPET / LPNT 0803..
SCR3216R03-0072G-08	32	16	151	91	72	40	32	17	3	LPET / LPNT 0803..
SCR3317R03-0074G-08	33	17	154	94	74	40	32	18	3	LPET / LPNT 0803..
SCR3418R03-0077G-08	34	18	156	96	77	40	32	19	3	LPET / LPNT 0803..
SCR3517R03-0079G-09	35	17	166	96	79	50	40	18	3	LPET / LPNT 09T3..
SCR3618R03-0081G-09	36	18	168	98	81	50	40	19	3	LPET / LPNT 09T3..
SCR3719R03-0083G-09	37	19	170	100	83	50	40	20	3	LPET / LPNT 09T3..
SCR3820R03-0086G-09	38	20	173	103	86	50	40	21	3	LPET / LPNT 09T3..
SCR3921R03-0088G-09	39	21	175	105	88	50	40	22	3	LPET / LPNT 09T3..
SCR4022R03-0090G-09	40	22	177	107	90	50	40	23	3	LPET / LPNT 09T3..
SCR4121R03-0092G-10	41	21	179	109	92	50	40	22	3	LPET / LPNT 10T3..
SCR4222R03-0095G-10	42	22	182	112	95	50	40	23	3	LPET / LPNT 10T3..
SCR4323R03-0097G-10	43	23	185	115	97	50	40	24	3	LPET / LPNT 10T3..
SCR4424R03-0099G-10	44	24	187	117	99	50	40	25	3	LPET / LPNT 10T3..
SCR4525R03-0101G-10	45	25	190	120	101	50	40	26	3	LPET / LPNT 10T3..
SCR4626R03-0104G-10	46	26	192	122	104	50	40	27	3	LPET / LPNT 10T3..
SCR4727R03-0106G-10	47	27	195	125	106	50	40	28	3	LPET / LPNT 10T3..
SCR4823R03-0108G-13	48	23	198	128	108	55	40	23	3	LPET / LPNT 1304..
SCR4924R03-0110G-13	49	24	200	130	110	55	40	24	3	LPET / LPNT 1304..
SCR5025R03-0113G-13	50	25	203	133	113	55	40	25	3	LPET / LPNT 1304..

HINWEIS: Trägerwerkzeuge werden mit Klemmschrauben und Ersatzschrauben geliefert, jedoch ohne Schlüssel.
Ersatzteile und Zubehör siehe Seite 184.

INFORMATION: Holders will be supplied with clamping screws and spare screws, however without key. Spare parts and accessories see page 184.

NOTA: L'utensile é fornito completo di vite, 1 vite di ricambio, ma SENZA chiave. Ricambi a pagina 184.

-ALU

- Hochglänzende, polierte Oberfläche der Wendeschneidplatte für minimale Verklebung und optimales Zerspanungsverhalten
- Hochpositive Schneidengeometrie
- Spezielle Geometrie für die Bearbeitung von Aluminiumwerkstoffen, NE-Metallen und Kunststoffen



-ALU

- *Ground and polished insert surface for minimum friction and optimum cutting performance*
- *Highpositive geometry*
- *Special geometry for machining aluminium, non-ferrous materials and synthetics*

-ALU

- Geometria lappata per un ottimo taglio del materiale e per ridurre incollaggi sulla superficie
- Geometria con spoglia superiore molto positiva
- Geometria dedicata alla lavorazione di materiali non ferrosi, ghise e plastiche

-EN/ER/EL

- Standardgeometrie für die Bearbeitung von Stahl, Guss und rostfreiem Stahl



-EN/ER/EL

- *Standard geometry for machining steel, stainless steel and cast iron*

-EN/ER/EL

- Geometria Standard per la lavorazione di acciai, acciai inossidabili e ghise acciai

-WI/AWI

- Extrem hochwertige Oberflächen durch Schleppschnide
- Breitschlichtgeometrie
- Erhöhter Vorschub für optimalen Spanbruch, geringere Bearbeitungszeiten und somit höhere Wirtschaftlichkeit



-WI/AWI

- *Extremely good surface finish with wiper geometry*
- *Wiper edge geometry*
- *Increased feed rate for better chip breaking, reduced machine time and therefore better productivity*

-WI/AWI

- Geometria con tecnologia wiper per ottime finiture superficiali
- Grazie al raschiante è possibile incrementare avanzamenti e ridurre tempi ciclo
- Geometria raschiante con tecnologia wiper su inserto -ALU per una migliorata finitura superficiale di leghe non ferrose, alluminio e plastiche

Hartmetall beschichtet / Carbide grade coated / Metallo duro rivestito**AK2015** Erste Wahl für die **Bearbeitung von Gusswerkstoffen.***First choice for machining cast materials.*

Qualità per la lavorazione di materiali non ferrosi, ghise e plastiche.

AM35C Erste Wahl für die **Bearbeitung von Stahl.***First choice for machining steel.*

Qualità per la lavorazione di acciai generici.

AM5035 Erste Wahl für die **Bearbeitung rostfreier Stähle.***First choice for machining stainless steel.*

Qualità per la lavorazione di acciai inossidabili.

AM5035 (AL350) – HC - P40, HC - M35**PVD-Mehrlagenbeschichtung,
Substrat + TiAlN****Hartmetallsorte für die Bearbeitung von rostfreien Stählen. Sorte ist auch zum Bearbeiten von Stahlwerkstoffen im niedrigen bis mittleren Festigkeitsbereich, sowie hochwarmfester Legierungen geeignet. Optimale Schneidkantenstabilität. Auch im mittleren und niedrigen Schnittgeschwindigkeitsbereich sehr gute Ergebnisse.***PVD-multilayer coating,
substrate + TiAlN**Grade for machining stainless steel, but can also be used for steel materials with low to medium hardness as well as high temperature alloys. Optimum cutting edge stability. Excellent results at low to medium cutting speeds.*Rivestimento multistrato PVD,
substrato + TiAlN

Qualità di metallo duro per lavorazione di acciaio inossidabile, anche idonea per acciai con durezza medio-bassa e per leghe altamente legate. Ottima stabilità tagliente. Eccellenti risultati a velocità di taglio medio basse.

AK2015 – HC - P15, HC - K15 - CVD**CVD-Mehrlagenbeschichtung,****Substrat + TiCN + TiCN + TiCNB + Al₂O₃****Das Hauptanwendungsgebiet dieser Sorte ist die Bearbeitung von Gusswerkstoffen aller Art. Sie eignet sich aber auch zum Bearbeiten von Stahlwerkstoffen. Das neue Substrat gewährleistet die erforderliche Zähigkeit und Warmfestigkeit.***CVD-multilayer coating,**substrate + TiCN + TiCN + TiCNB + Al₂O₃**The main application area for this grade is the machining of all cast materials. It is also suitable for machining steel. The new substrate offers the necessary toughness and heat resistance.*

Rivestimento multistrato CVD,

substrato + TiCN + TiCN + TiCNB + Al₂O₃

Grado studiato per lavorare materiali teneri stampati o da fusione. In alcune applicazioni idoneo anche alla lavorazione di acciai. Lo speciale substrato offre il giusto compromesso tra tenacità e resistenza all'usura.

AL10 – HC - P10, HC - M15, HC - K10, HC - N15, HC - S10**PVD-Mehrlagenbeschichtung,****Substrat + AlTiN****Extrem verschleißfeste Sorte zur Bearbeitung von Stählen und Grauguss. Diese Sorte zeichnet sich durch hohe Beschichtungshärte und äußerst hohe Verschleißfestigkeit aus. Besonders geeignet für sehr hohe Schnittgeschwindigkeiten.***PVD-multilayer coating,**substrate + AlTiN**Extremely wear resistant grade for machining steel materials, cast iron and non-ferrous products. Due to high hardness in coating, high wear-resistance can be achieved. Specially suitable for high cutting speeds.*

Rivestimento multistrato PVD,

substrato + AlTiN

Grado dall'elevata resistente all'usura per la lavorazione di acciai, ghise e materiali non ferrosi. Il rivestimento di elevata durezza assicura un'ottima resistenza all'usura. Valido per elevate velocità di taglio.

AM35C – HC - P35, HC - M30**CVD-Mehrlagenbeschichtung,****Substrat + TiC + TiCN + TiN****Hartmetallsorte mit hoher Zähigkeit für die Stahlbearbeitung im mittleren Schnittgeschwindigkeitsbereich.***CVD-multilayer coating,**substrate + TiC + TiCN + TiN**Carbide grade with high toughness for machining steel materials at medium cutting speeds.*

Rivestimento multistrato CVD,

substrato + TiC + TiCN + TiN

Grado di metallo duro universale per la lavorazione di acciai a medie velocità di taglio.

AR26C – HC - P25, HC - K20**CVD-Mehrlagenbeschichtung,****Substrat + TiN + TiCN + Al₂O₃****Hartmetallsorte mit hoher Verschleißfestigkeit für die Bearbeitung von Guss- und Stahlwerkstoffen.***CVD-multilayer coating,**substrate + TiN + TiCN + Al₂O₃**Carbide grade with high wear-resistance for machining cast iron and steel materials.*

Rivestimento multistrato CVD,

substrato + TiC + TiCN + Al₂O₃

Qualità di metallo duro con alta resistenza all'usura per la lavorazione di ghise ed alcuni acciai teneri debolmente legati o dal basso tenore di carbonio.

Grade description

Descrizione delle Qualità

Hartmetall unbeschichtet / Carbide grade uncoated / Metallo duro non rivestito

AK10 – HW - K10, HW - N10, HW - S10

Hartmetallsorte für die Bearbeitung von Aluminium, Aluminiumlegierungen, Nichteisenmetallen und Kunststoffen. Die Sorte ist auch bedingt geeignet für die Bearbeitung von Gusswerkstoffen, Titan und Titanlegierungen. Die Wendeschneidplatte ist umfangsseitig geschliffen und die Spanfläche poliert.

Grade for machining aluminium, aluminium alloys, non-ferrous metals and plastics. Grade can also be used for machining cast iron and temperature metals. Insert is periphery-ground and the chipbreaker is polished.

Metallo duro micrograna per la lavorazione di alluminio, leghe di alluminio, metalli non ferrosi e leghe plastiche. Valido anche in determinate condizioni di stabilità per la finitura di ghisa e leghe altamente legate. Gli inserti sono lappati sulla superficie e rettificati sul perimetro.

AP40 – HW - P40, HW - M35

Speziell für die Stahlbearbeitung bei Schnittgeschwindigkeiten unter 80 m/min oder bei ungünstigen Stabilitätsverhältnissen.

Special carbide grade for steel materials at cutting speeds below 80 m/min and unstable machining conditions.

Grado di metallo duro tenace per lavorare acciai a velocità di taglio inferiori agli 80 m/min ed in condizioni instabili di lavoro.

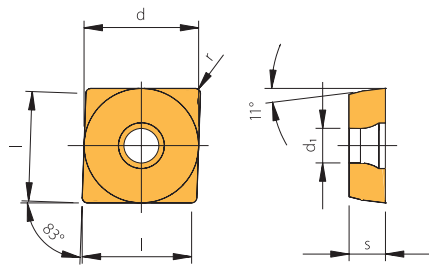

LPET

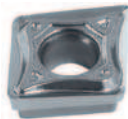

Bezeichnung Designation Articolo	l	d ^o	s	r	d ₁	beschichtet coated rivestito			unbeschichtet uncoated non rivestito
						AL10	AM35C	AR26C	AK10
LPET 050204FN-ALU	5,0	5,8	2,10	0,4	2,25	●			●
LPET 060204FN-ALU	6,0	6,5	2,38	0,4	2,50	●			●
LPET 070304FN-ALU	7,0	7,6	3,18	0,4	2,80	●			●
LPET 080304FN-ALU	8,0	8,5	3,18	0,4	3,40	●			●
LPET 09T304FN-ALU	9,0	9,6	3,00	0,4	3,40	●			●
LPET 10T304FN-ALU	10,0	10,6	3,97	0,4	4,40	●			●
LPET 130404FN-ALU	12,5	13,5	4,76	0,4	5,30	●			●
LPET 170508FN-ALU	16,0	17,5	5,56	0,8	5,30	●			●
LPET 040102FL-AWI*	4,0	4,5	1,80	0,2	2,10	●			●
LPET 040102FR-AWI*	4,0	4,5	1,80	0,2	2,10	●			●
LPET 040104FL-AWI*	4,0	4,5	1,80	0,4	2,10	●			●
LPET 040104FR-AWI*	4,0	4,5	1,80	0,4	2,10	●			●
LPET 050202FN-AWI	5,0	5,8	2,10	0,2	2,25	●			●
LPET 050204FN-AWI	5,0	5,8	2,10	0,4	2,25	●			●
LPET 060202FN-AWI	6,0	6,5	2,38	0,2	2,50	●			●
LPET 060204FN-AWI	6,0	6,5	2,38	0,4	2,50	●			●
LPET 070304FN-AWI	7,0	7,6	3,18	0,4	2,80	●			●
LPET 080304FN-AWI	8,0	8,5	3,18	0,4	3,40	●			●
LPET 09T304FN-AWI	9,0	9,6	3,97	0,4	3,40	●			●
LPET 10T304FN-AWI	10,0	10,6	3,97	0,4	4,40	●			●
LPET 10T308FN-AWI	10,0	10,6	3,97	0,8	4,40	●			●
LPET 130404FN-AWI	12,5	13,5	4,76	0,4	5,30	●			●
LPET 130408FN-AWI	12,5	13,5	4,76	0,8	5,30	●			●
LPET 170508FN-AWI	16,0	17,5	5,56	0,8	5,30	●			●
LPET 060204EN-WI	6,0	6,5	2,38	0,4	2,5		●	●	
LPET 070304EN-WI	7,0	7,6	3,18	0,4	2,8		●	●	
LPET 080304EN-WI	8,0	8,5	3,18	0,4	3,4		●	●	
LPET 09T304EN-WI	9,0	9,6	3,97	0,4	3,4		●	●	
LPET 10T304EN-WI	10,0	10,6	3,97	0,4	4,4		●	●	
LPET 130404EN-WI	12,5	13,5	4,76	0,4	5,3		●	●	
LPET 170508EN-WI	16,0	17,5	5,56	0,8	5,3		●	●	

- * Rechter Halter → Rechte Wendeschneidplatte
- * Right-hand holder → Right-hand indexable insert
- * Utensile Destro → Inserto Destro

- Maß „d“ gemessen auf Höhe Maß „s“
- Dimension “d” measured to height “s”
- Dimensione “d” misurata ad altezza “s”

- Hauptanwendung
Main application
Applicazione principale
- Nebenanwendung
Secondary application
Applicazione secondaria

P	●	●	●	
M	●	○	●	
K	○		●	○
N				●
S	○	○		
H	○			

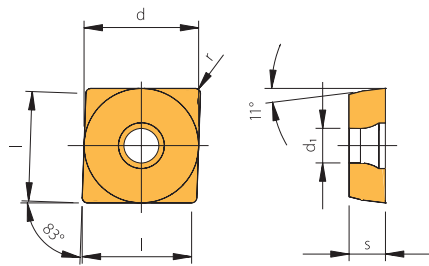

LPNT



Bezeichnung Designation Articolo	l	d ^o	s	r	d ₁	beschichtet coated rivestito					unbeschichtet uncoated non rivestito
						AM5035	AK2015	AL350	AM35C	AR26C	AP40
LPNT 040102ER*	4,0	4,5	1,80	0,2	2,10			●	●	●	●
LPNT 040104ER*	4,0	4,5	1,80	0,4	2,10	●	●	●	●	●	●
LPNT 040102EL	4,0	4,5	1,80	0,2	2,10			●	●	●	●
LPNT 040104EL	4,0	4,5	1,80	0,4	2,10	●	●	●	●	●	●
LPNT 050202EN	5,0	5,8	2,10	0,2	2,25			●	●	●	●
LPNT 050204EN	5,0	5,8	2,10	0,4	2,25	●	●	●	●	●	●
LPNT 060202EN	6,0	6,5	2,38	0,2	2,50			●	●	●	●
LPNT 060204EN	6,0	6,5	2,38	0,4	2,50	●	●	●	●	●	●
LPNT 070304EN	7,0	7,6	3,18	0,4	2,80	●	●	●	●	●	●
LPNT 080304EN	8,0	8,5	3,18	0,4	3,40	●	●	●	●	●	●
LPNT 09T304EN	9,0	9,6	3,97	0,4	3,40	●	●	●	●	●	●
LPNT 10T304EN	10,0	10,6	3,97	0,4	4,40	●	●	●	●	●	●
LPNT 10T308EN	10,0	10,6	3,97	0,8	4,40			●	●	●	●
LPNT 130404EN	12,5	13,5	4,76	0,4	5,30	●	●	●	●	●	●
LPNT 130408EN	12,5	13,5	4,76	0,8	5,30			●	●	●	●
LPNT 170508EN	16,0	17,5	5,56	0,8	5,30	●	●	●	●	●	●

- * Rechter Halter → Rechte Wendeschneidplatte
- * Right-hand holder → Right-hand indexable insert
- * Utensile Destro → Inserto Destro

- Maß „d“ gemessen auf Höhe Maß „s“
- Dimension “d” measured to height “s”
- Dimensione “d” misurata ad altezza “s”

- Hauptanwendung
Main application
Applicazione principale
- Nebenanwendung
Secondary application
Applicazione secondaria

P	○	○	○	●	●	●
M	●		●	○	●	
K		●			●	
N						
S	○		○	○		
H						

SHARK-CUT® Standard

Halter Holder Utensile	Schraube Srew Vite	Anzugsmoment Torque Momento di serraggio	Schlüssel Key Chiave
SC08R/L- ..SP04	7815108	0,6 Nm	T 5106
SC10R/L- ..SP05	7815110	0,6 Nm	T 5106
SC12R/L- ..SP06	SS 5151	1,0 Nm	T 5107
SC14R/L- ..SP07	SS 1751	1,3 Nm	T 5108
SC16R/L- ..SP08	SS 8831	2,2 Nm	T 5108
SC18R/L- ..SP09	SS 8831	2,2 Nm	T 5108
SC20R/L- ..SP10	SS 2314	3,4 Nm	T 5115
SC25R/L- ..SP13	7822114	6,2 Nm	T 5120
SC32R/L- ..SP17	7822114	6,2 Nm	T 5120

SHARK-CUT® Rebore 2-schneidig / 2 flute / 2 taglianti

Halter Holder Utensile	Schraube Srew Vite	Anzugsmoment Torque Momento di serraggio	Schlüssel Key Chiave
SCR 1204 R02..	7815108	0,6 Nm	T 5106
SCR 1305 R02..	7815108	0,6 Nm	T 5106
SCR 1406 R02..	7815108	0,6 Nm	T 5106
SCR 1507 R02..	7815108	0,6 Nm	T 5106
SCR 1606 R02..	7815110	0,6 Nm	T 5106
SCR 1707 R02..	7815110	0,6 Nm	T 5106
SCR 17575 R02..	7815110	0,6 Nm	T 5106
SCR 1806 R02..	SS 5151	1,0 Nm	T 5107
SCR 1907 R02..	SS 5151	1,0 Nm	T 5107
SCR 2006 R02..	SS 1751	1,3 Nm	T 5108
SCR 2107 R02..	SS 1751	1,3 Nm	T 5108
SCR 2208 R02..	SS 1751	1,3 Nm	T 5108
SCR 2309 R02..	SS 1751	1,3 Nm	T 5108
SCR 2408 R02..	SS 8831	2,2 Nm	T 5108
SCR 2509 R02..	SS 8831	2,2 Nm	T 5108
SCR 2608 R02..	SS 8831	2,2 Nm	T 5108
SCR 2709 R02..	SS 8831	2,2 Nm	T 5108
SCR 2810 R02..	SS 8831	2,2 Nm	T 5108
SCR 2909 R02..	SS 2314	3,4 Nm	T 5115
SCR 3010 R02..	SS 2314	3,4 Nm	T 5115
SCR 3111 R02..	SS 2314	3,4 Nm	T 5115
SCR 3212 R02..	SS 2314	3,4 Nm	T 5115
SCR 3313 R02..	SS 2314	3,4 Nm	T 5115
SCR 3414 R02..	SS 2314	3,4 Nm	T 5115
SCR 3510 R02..	7822114	6,2 Nm	T 5120
SCR 3611 R02..	7822114	6,2 Nm	T 5120
SCR 3712 R02..	7822114	6,2 Nm	T 5120
SCR 3813 R02..	7822114	6,2 Nm	T 5120
SCR 3914 R02..	7822114	6,2 Nm	T 5120
SCR 4015 R02..	7822114	6,2 Nm	T 5120
SCR 4116 R02..	7822114	6,2 Nm	T 5120
SCR 4217 R02..	7822114	6,2 Nm	T 5120
SCR 4318 R02..	7822114	6,2 Nm	T 5120
SCR 4419 R02..	7822114	6,2 Nm	T 5120
SCR 4513 R02..	7822114	6,2 Nm	T 5120
SCR 4614 R02..	7822114	6,2 Nm	T 5120
SCR 4715 R02..	7822114	6,2 Nm	T 5120
SCR 4816 R02..	7822114	6,2 Nm	T 5120
SCR 4917 R02..	7822114	6,2 Nm	T 5120
SCR 5018 R02..	7822114	6,2 Nm	T 5120

HINWEIS: Drehmoment-Schraubendreher siehe Seite 281.

INFORMATION: For torque screw drivers see page 281.

NOTA: Chiavi dinamometriche a pagina 281.



SHARK-CUT® **Rebore 3-schneidig / 3 flute / 3 taglienti**

Halter Holder Utensile	Schraube Srew Vite	Anzugsmoment Torque Momento di serraggio	Schlüssel Key Chiave
SCR 2412 R03..	SS 5151	1,0 Nm	T 5107
SCR 2513 R03..	SS 5151	1,0 Nm	T 5107
SCR 2612 R03..	SS 1751	1,3 Nm	T 5108
SCR 2713 R03..	SS 1751	1,3 Nm	T 5108
SCR 2814 R03..	SS 1751	1,3 Nm	T 5108
SCR 2913 R03..	SS 8831	2,2 Nm	T 5108
SCR 3014 R03..	SS 8831	2,2 Nm	T 5108
SCR 3115 R03..	SS 8831	2,2 Nm	T 5108
SCR 3216 R03..	SS 8831	2,2 Nm	T 5108
SCR 3317 R03..	SS 8831	2,2 Nm	T 5108
SCR 3418 R03..	SS 8831	2,2 Nm	T 5108
SCR 3517 R03..	SS 8831	2,2 Nm	T 5108
SCR 3618 R03..	SS 8831	2,2 Nm	T 5108
SCR 3719 R03..	SS 8831	2,2 Nm	T 5108
SCR 3820 R03..	SS 8831	2,2 Nm	T 5108
SCR 3921 R03..	SS 8831	2,2 Nm	T 5108
SCR 4022 R03..	SS 8831	2,2 Nm	T 5108
SCR 4121 R03..	SS 2314	3,4 Nm	T 5115
SCR 4222 R03..	SS 2314	3,4 Nm	T 5115
SCR 4323 R03..	SS 2314	3,4 Nm	T 5115
SCR 4424 R03..	SS 2314	3,4 Nm	T 5115
SCR 4525 R03..	SS 2314	3,4 Nm	T 5115
SCR 4626 R03..	SS 2314	3,4 Nm	T 5115
SCR 4727 R03..	SS 2314	3,4 Nm	T 5115
SCR 4823 R03..	7822114	6,2 Nm	T 5120
SCR 4924 R03..	7822114	6,2 Nm	T 5120
SCR 5025 R03..	7822114	6,2 Nm	T 5120

HINWEIS: Drehmoment-Schraubendreher siehe Seite 281.

INFORMATION: For torque screw drivers see page 281.

NOTA: Chiavi dinamometriche a pagina 281.



ISO	Werkstoff	Zugfestigkeit [N/mm ²]	Schnittgeschwindigkeit V _c [m/min]								
			AM5035	AK2015	AL10	AL350	AM35C	AR26C	AK10	AP40	
P	Unlegierter Stahl und Stahlguss	ca. 0,15 % C, gegläht	340	120 - 230	120 - 220	200 - 300	120 - 230	140 - 250	150 - 280	-	80 - 140
		ca. 0,45 % C, gegläht	640	80 - 160	100 - 160	170 - 280	80 - 160	100 - 180	120 - 200	-	70 - 100
		ca. 0,45 % C, vergütet	830	80 - 160	100 - 160	160 - 250	80 - 160	100 - 180	120 - 200	-	70 - 100
		ca. 0,75 % C, gegläht	900	60 - 130	80 - 140	150 - 250	60 - 130	80 - 150	100 - 180	-	60 - 100
		ca. 0,75 % C, vergütet	1000	50 - 130	80 - 130	150 - 250	50 - 130	70 - 150	100 - 170	-	50 - 100
	Niedrig legierter Stahl und Stahlguss	geglüht	600	80 - 160	100 - 160	170 - 270	80 - 160	100 - 180	120 - 200	-	60 - 100
		vergütet	920	60 - 130	70 - 130	160 - 250	60 - 130	80 - 150	90 - 160	-	50 - 90
		vergütet	1000	60 - 120	60 - 130	150 - 250	60 - 120	80 - 150	80 - 160	-	50 - 80
		vergütet	1170	60 - 100	60 - 110	150 - 220	60 - 100	70 - 120	80 - 140	-	50 - 80
	Hochlegierter Stahl, hochlegierter Werkzeugstahl und Stahlguss	geglüht	670	80 - 140	90 - 140	-	80 - 140	100 - 160	110 - 180	-	60 - 80
gehärtet und angelassen		1100	50 - 100	60 - 110	-	50 - 100	60 - 120	80 - 140	-	-	
Nichtrostender Stahl und Stahlguss	ferritisch/martensitisch, gegläht	670	50 - 200	-	160 - 280	50 - 200	100 - 180	-	-	-	
	martensitisch, vergütet	1000	50 - 150	-	140 - 280	50 - 150	80 - 150	-	-	-	
M	Nichtrostender Stahl und Stahlguss	austenitisch und austenitisch/ferritisch, abgeschreckt	450 - 600	50 - 190	-	140 - 280	50 - 190	100 - 190	-	-	50 - 150
		600 - 900	50 - 100	-	-	50 - 100	-	-	-	-	40 - 90
K	Grauguss	perlitisch, ferritisch	500 - 700	-	140 - 240	170 - 300	-	-	120 - 200	100 - 150	-
		perlitisch, martensitisch	700 - 850	-	140 - 240	150 - 270	-	-	120 - 200	100 - 150	-
			800 - 1100	-	120 - 190	120 - 240	-	-	100 - 160	80 - 120	-
	Gusseisen mit Kugelgraphit	ferritisch	550	-	130 - 240	140 - 230	-	-	110 - 200	100 - 140	-
		perlitisch	800	-	130 - 240	120 - 170	-	-	110 - 200	100 - 140	-
	Temperguss	ferritisch	450	-	120 - 240	150 - 200	-	-	100 - 200	100 - 160	-
perlitisch		750	-	120 - 240	140 - 200	-	-	100 - 200	100 - 160	-	
N	Aluminium-Knetlegierungen	nicht aushärtbar	200	-	-	800 - 1300	-	-	-	100 - 500	-
		aushärtbar, ausgehärtet	350	-	-	400 - 900	-	-	-	100 - 300	-
	Aluminium-Gusslegierungen	≤ 12% Si, ausgehärtet	250	-	-	250 - 800	-	-	-	100 - 500	-
		≤ 12% Si, aushärtbar, ausgehärtet	300	-	-	200 - 550	-	-	-	100 - 300	-
		≤ 12% Si, nicht aushärtbar	450	-	-	200 - 550	-	-	-	100 - 300	-
	Kupfer und Kupferlegierungen (Bronze/Messing)	Automatenlegierung, Pb > 1%	400	-	-	-	-	-	-	100 - 500	-
		Messing, Rotguss	300	-	-	-	-	-	-	100 - 500	-
		Aluminiumbronze	500	-	-	-	-	-	-	100 - 300	-
		Kupfer und Elektrolytkupfer	200	-	-	-	-	-	-	100 - 300	-
	Nichtmetallische Werkstoffe	Duroplaste		-	-	-	-	-	-	80 - 180	-
Faserverstärkte Kunststoffe			-	-	-	-	-	-	60 - 150	-	
Hartgummi			-	-	-	-	-	-	100 - 250	-	
S	Warmfeste Legierungen	Fe-Basis gegläht	700	20 - 50	-	20 - 50	20 - 50	-	-	-	-
		Fe-Basis ausgehärtet	950	20 - 40	-	20 - 50	20 - 40	-	-	-	-
		Ni- oder Co-Basis gegläht	800	15 - 25	-	15 - 40	15 - 25	-	-	-	-
		Ni- oder Co-Basis gegossen	1100	10 - 20	-	15 - 30	-	-	-	-	-
		Ni- oder Co-Basis ausgehärtet	1200	10 - 20	-	15 - 30	-	-	-	-	-
	Titanlegierungen	Reintitan	500 - 700	50 - 120	-	-	50 - 120	-	-	50 - 120	-
Alpha+Beta-Legierungen, ausgehärtet	700 - 1000	30 - 50	-	-	30 - 50	-	-	30 - 50	-		
H	Gehärteter Stahl	gehärtet und angelassen	1000 - 1350	-	-	-	-	-	-	-	-
		gehärtet und angelassen	1350 - 1700	-	-	-	-	-	-	-	-
	Hartguss	gegossen	1350	-	-	-	-	-	-	-	-
Gehärtetes Gusseisen	gehärtet und angelassen	1900	-	-	-	-	-	-	-	-	

Die Tabellenwerte sind Richtwerte. Es kann notwendig sein, die Werte den jeweiligen Bearbeitungsumständen anzupassen.

ISO	Material	Tensile strength [N/mm ²]	Cutting speed V _c (m/min)								
			AM5035	AK2015	AL10	AL350	AM35C	AR26C	AK10	AP40	
P	Unalloyed steel and cast steel	ca. 0,15 % C, annealed	340	120 - 230	120 - 220	200 - 300	120 - 230	140 - 250	150 - 280	-	80 - 140
		ca. 0,45 % C, annealed	640	80 - 160	100 - 160	170 - 280	80 - 160	100 - 180	120 - 200	-	70 - 100
		ca. 0,45 % C, hardened and tempered	830	80 - 160	100 - 160	160 - 250	80 - 160	100 - 180	120 - 200	-	70 - 100
		ca. 0,75 % C, annealed	900	60 - 130	80 - 140	150 - 250	60 - 130	80 - 150	100 - 180	-	60 - 100
		ca. 0,75 % C, hardened and tempered	1000	50 - 130	80 - 130	150 - 250	50 - 130	70 - 150	100 - 170	-	50 - 100
	Low alloyed steel and cast steel	annealed	600	80 - 160	100 - 160	170 - 270	80 - 160	100 - 180	120 - 200	-	60 - 100
		hardened and tempered	920	60 - 130	70 - 130	160 - 250	60 - 130	80 - 150	90 - 160	-	50 - 90
		hardened and tempered	1000	60 - 120	60 - 130	150 - 250	60 - 120	80 - 150	80 - 160	-	50 - 80
		hardened and tempered	1170	60 - 100	60 - 110	150 - 220	60 - 100	70 - 120	80 - 140	-	50 - 80
	High alloyed steel, high alloyed toolsteel and cast steel	annealed	670	80 - 140	90 - 140	-	80 - 140	100 - 160	110 - 180	-	60 - 80
hardened and tempered		1100	50 - 100	60 - 110	-	50 - 100	60 - 120	80 - 140	-	-	
Stainless steel and cast steel	ferritic / martensitic, annealed	670	50 - 200	-	160 - 280	50 - 200	100 - 180	-	-	-	
	martensitic, hardened and tempered	1000	50 - 150	-	140 - 280	50 - 150	80 - 150	-	-	-	
M	Stainless steel and cast steel	austenitic and	450 - 600	50 - 190	-	140 - 280	50 - 190	100 - 190	-	-	50 - 150
		austenitic/ferritic, chilled	600 - 900	50 - 100	-	-	50 - 100	-	-	-	40 - 90
K	Cast iron	pearlitic, ferritic	500 - 700	-	140 - 240	170 - 300	-	-	120 - 200	100 - 150	-
		pearlitic, martensitic	700 - 850	-	140 - 240	150 - 270	-	-	120 - 200	100 - 150	-
			800 - 1100	-	120 - 190	120 - 240	-	-	100 - 160	80 - 120	-
	Cast iron with nodular graphite	ferritic	550	-	130 - 240	140 - 230	-	-	110 - 200	100 - 140	-
		pearlitic	800	-	130 - 240	120 - 170	-	-	110 - 200	100 - 140	-
	Malleable cast iron	ferritic	450	-	120 - 240	150 - 200	-	-	100 - 200	100 - 160	-
pearlitic		750	-	120 - 240	140 - 200	-	-	100 - 200	100 - 160	-	
N	Aluminium alloys, long chipping	not heat treatable	200	-	-	800 - 1300	-	-	-	100 - 500	-
		heat treatable, heat - treated	350	-	-	400 - 900	-	-	-	100 - 300	-
	Casted aluminium alloys	≤ 12% Si, hardened	250	-	-	250 - 800	-	-	-	100 - 500	-
		≤ 12% Si, heat treatable	300	-	-	200 - 550	-	-	-	100 - 300	-
		≤ 12% Si, not heat treatable	450	-	-	200 - 550	-	-	-	100 - 300	-
	Copper and copper alloys (brass/bronze)	Lead alloys, Pb > 1 %	400	-	-	-	-	-	-	100 - 500	-
		Brass, bronze	300	-	-	-	-	-	-	100 - 500	-
Aluminium bronze		500	-	-	-	-	-	-	100 - 300	-	
Copper and electrolyte copper		200	-	-	-	-	-	-	100 - 300	-	
Non ferrous materials	Duroplastics		-	-	-	-	-	-	80 - 180	-	
	Re- inforced plastics		-	-	-	-	-	-	60 - 150	-	
	Hard rubber		-	-	-	-	-	-	100 - 250	-	
S	High temperature resistant alloys	Fe-alloyed, annealed	700	20 - 50	-	20 - 50	20 - 50	-	-	-	-
		Fe-alloyed, heat-treated	950	20 - 40	-	20 - 50	20 - 40	-	-	-	-
		Ni- or annealed	800	15 - 25	-	15 - 40	15 - 25	-	-	-	-
		Co - based, casting	1100	10 - 20	-	15 - 30	-	-	-	-	-
		Co - based, heat-treated	1200	10 - 20	-	15 - 30	-	-	-	-	-
	Titanium alloys, high strength	Pure titan	500 - 700	50 - 120	-	-	50 - 120	-	-	50 - 120	-
Alpha-and Beut-alloys, hardened		700 - 1000	30 - 50	-	-	30 - 50	-	-	30 - 50	-	
H	Hardened steel	hardened and tempered	1000 - 1350	-	-	-	-	-	-	-	-
		hardened and tempered	1350 - 1700	-	-	-	-	-	-	-	-
	Hard cast iron	casting	1350	-	-	-	-	-	-	-	-
Hardened cast iron	hardened and tempered	1900	-	-	-	-	-	-	-	-	

The datas given are only approximate values. It can be necessary to adjust these datas to the individual machining operation.

ISO	Materiale	Resistenza [N/mm ²]	Velocità di taglio V _c (m/min)								
			AM5035	AK2015	AL10	AL350	AM35C	AR26C	AK10	AP40	
P	Acciaio non legati o debolmente legati	ca. 0,15 % C, ricotto	340	120 - 230	120 - 220	200 - 300	120 - 230	140 - 250	150 - 280	-	80 - 140
		ca. 0,45 % C, ricotto	640	80 - 160	100 - 160	170 - 280	80 - 160	100 - 180	120 - 200	-	70 - 100
		ca. 0,45 % C, temprato	830	80 - 160	100 - 160	160 - 250	80 - 160	100 - 180	120 - 200	-	70 - 100
		ca. 0,75 % C, ricotto	900	60 - 130	80 - 140	150 - 250	60 - 130	80 - 150	100 - 180	-	60 - 100
		ca. 0,75 % C, temprato	1000	50 - 130	80 - 130	150 - 250	50 - 130	70 - 150	100 - 170	-	50 - 100
	Acciaio debolmente legati	ricotto	600	80 - 160	100 - 160	170 - 270	80 - 160	100 - 180	120 - 200	-	60 - 100
		temprato	920	60 - 130	70 - 130	160 - 250	60 - 130	80 - 150	90 - 160	-	50 - 90
		temprato	1000	60 - 120	60 - 130	150 - 250	60 - 120	80 - 150	80 - 160	-	50 - 80
		temprato	1170	60 - 100	60 - 110	150 - 220	60 - 100	70 - 120	80 - 140	-	50 - 80
	Acciai fortemente legati, acciai da utensili	ricotto	670	80 - 140	90 - 140	-	80 - 140	100 - 160	110 - 180	-	60 - 80
temprato e rinvenuto		1100	50 - 100	60 - 110	-	50 - 100	60 - 120	80 - 140	-	-	
Acciai inossidabili e stampati	ferritico / martensitico, ricotto	670	50 - 200	-	160 - 280	50 - 200	100 - 180	-	-	-	
	martensitico, temprato	1000	50 - 150	-	140 - 280	50 - 150	80 - 150	-	-	-	
M	Acciai inossidabili e stampati	austenitico e austenitico/ferritico	450 - 600	50 - 190	-	140 - 280	50 - 190	100 - 190	-	-	50 - 150
		trattato o temprato	600 - 900	50 - 100	-	-	50 - 100	-	-	-	40 - 90
K	Ghisa grigia	perlitica, ferritica	500 - 700	-	140 - 240	170 - 300	-	-	120 - 200	100 - 150	-
		perlitica, martensitica	700 - 850	-	140 - 240	150 - 270	-	-	120 - 200	100 - 150	-
			800 - 1100	-	120 - 190	120 - 240	-	-	100 - 160	80 - 120	-
	Ghisa sferoidale	ferritica	550	-	130 - 240	140 - 230	-	-	110 - 200	100 - 140	-
		perlitica	800	-	130 - 240	120 - 170	-	-	110 - 200	100 - 140	-
	Ghisa malleabile	ferritica	450	-	120 - 240	150 - 200	-	-	100 - 200	100 - 160	-
perlitica		750	-	120 - 240	140 - 200	-	-	100 - 200	100 - 160	-	
N	Leghe di alluminio a truciolo lungo	non trattabile	200	-	-	800 - 1300	-	-	-	100 - 500	-
		temprabile, trattato	350	-	-	400 - 900	-	-	-	100 - 300	-
	Fusioni di Alluminio	≤ 12% Si, temprato	250	-	-	250 - 800	-	-	-	100 - 500	-
		≤ 12% Si, temprabile, trattato	300	-	-	200 - 550	-	-	-	100 - 300	-
		≤ 12% Si, non trattabile	450	-	-	200 - 550	-	-	-	100 - 300	-
	Leghe di Rame (Bronzo, Ottone)	Leghe di Piombo, Pb > 1 %	400	-	-	-	-	-	-	100 - 500	-
		Ottone, Bronzo	300	-	-	-	-	-	-	100 - 500	-
		Bronzo alluminio	500	-	-	-	-	-	-	100 - 300	-
		Rame e rame elettrolitico	200	-	-	-	-	-	-	100 - 300	-
	Materiali non ferrosi	Plastiche dure		-	-	-	-	-	-	80 - 180	-
Plastiche rinforzate			-	-	-	-	-	-	60 - 150	-	
Gomme dure			-	-	-	-	-	-	100 - 250	-	
S	Leghe refrattarie, Superleghe	a base di Fe, ricotto	700	20 - 50	-	20 - 50	20 - 50	-	-	-	-
		a base di Fe, temprato	950	20 - 40	-	20 - 50	20 - 40	-	-	-	-
		a base di Ni, ricotto	800	15 - 25	-	15 - 40	15 - 25	-	-	-	-
		a base di Co, da fusione	1100	10 - 20	-	15 - 30	-	-	-	-	-
		a base di Co, temprato	1200	10 - 20	-	15 - 30	-	-	-	-	-
	Leghe di Titanio	titanio puro	500 - 700	50 - 120	-	-	50 - 120	-	-	50 - 120	-
Leghe Alfa e Beta, trattate		700 - 1000	30 - 50	-	-	30 - 50	-	-	30 - 50	-	
H	Acciaio temprato	temprato e rinvenuto	1000 - 1350	-	-	-	-	-	-	-	-
		temprato e rinvenuto	1350 - 1700	-	-	-	-	-	-	-	-
	Ghisa temprata	da fusione	1350	-	-	-	-	-	-	-	-
	Ghisa trattata	temprato e rinvenuto	1900	-	-	-	-	-	-	-	-

I parametri di tagli indicati sono solo indicativi. E' necessario ottimizzarli ad ogni applicazione sulle specifiche condizioni di lavoro.

ISO-Application area
ISO-Campi di applicazione

ISO	Hartmetall beschichtet Carbide coated Metallo duro rivestito	Hartmetall unbeschichtet Carbide uncoated Metallo duro non rivestito	Schneidstoff Cutting material Materiale da taglio	Anwendung Application Parametri
P Stahl, Stahlguss, langspanender Temperguss <i>Steel, cast steel, long chipping malleable iron</i> Acciaio, acciaio colato, ghisa temprata a truciolo lungo	10	AL10	Zähigkeit Toughness / Tenacità Verschleißbeständigkeit / Wear resistance / Resistenza all'usura Vorschub Feed rate / Avanzamento Schnittgeschwindigkeit Cutting speed / Velocità di taglio	Zähigkeit Toughness / Tenacità Verschleißbeständigkeit / Wear resistance / Resistenza all'usura Vorschub Feed rate / Avanzamento Schnittgeschwindigkeit Cutting speed / Velocità di taglio
	20	AR26C, AM35C, AK2015		
	30	AM35C, AP40		
	40	AL350, AM5035		
	50			
M Rostfreier Stahl, Stahlguss, Manganstahl, Automatenstahl <i>Stainless steel, cast steel, manganese steel, free cutting steel</i> Acciaio inossidabile, acciaio colato, acciaio al manganese, ghisa legata, ghisa temprata, acciaio automatico, leghe refrattarie	10	AL10	Zähigkeit Toughness / Tenacità Verschleißbeständigkeit / Wear resistance / Resistenza all'usura Vorschub Feed rate / Avanzamento Schnittgeschwindigkeit Cutting speed / Velocità di taglio	Zähigkeit Toughness / Tenacità Verschleißbeständigkeit / Wear resistance / Resistenza all'usura Vorschub Feed rate / Avanzamento Schnittgeschwindigkeit Cutting speed / Velocità di taglio
	20			
	30	AM35C, AL350, AM5035		
	40			
	50			
K Grauguss, Kokillenhartguss, kurzspanender Temperguss <i>Grey cast iron, chilled hard cast iron, short chipping malleable iron</i> Ghisa grigia, ghisa fusa in conchiglia, ghisa temprata a truciolo corto, acciaio temprato, metalli non ferrosi, plastica, legno	10	AL10, AK2015	Zähigkeit Toughness / Tenacità Verschleißbeständigkeit / Wear resistance / Resistenza all'usura Vorschub Feed rate / Avanzamento Schnittgeschwindigkeit Cutting speed / Velocità di taglio	Zähigkeit Toughness / Tenacità Verschleißbeständigkeit / Wear resistance / Resistenza all'usura Vorschub Feed rate / Avanzamento Schnittgeschwindigkeit Cutting speed / Velocità di taglio
	20	AR26C, AK10		
	30			
	40			
	50			
N Aluminium und Al-Legierungen, nichtmetallische Werkstoffe <i>Aluminium and Al-alloys, non ferrous materials</i> Alluminio e leghe di alluminio, materiali non metallici	10		Zähigkeit Toughness / Tenacità Verschleißbeständigkeit / Wear resistance / Resistenza all'usura Vorschub Feed rate / Avanzamento Schnittgeschwindigkeit Cutting speed / Velocità di taglio	Zähigkeit Toughness / Tenacità Verschleißbeständigkeit / Wear resistance / Resistenza all'usura Vorschub Feed rate / Avanzamento Schnittgeschwindigkeit Cutting speed / Velocità di taglio
	20	AK10		
	30			
	40			
	50			
S Warmfeste Legierungen, Titanlegierungen <i>High temperature resistant alloys, Titanium alloys</i> Leghe refrattarie, leghe di titanio	10	AL10	Zähigkeit Toughness / Tenacità Verschleißbeständigkeit / Wear resistance / Resistenza all'usura Vorschub Feed rate / Avanzamento Schnittgeschwindigkeit Cutting speed / Velocità di taglio	Zähigkeit Toughness / Tenacità Verschleißbeständigkeit / Wear resistance / Resistenza all'usura Vorschub Feed rate / Avanzamento Schnittgeschwindigkeit Cutting speed / Velocità di taglio
	20			
	30	AL350, AM5035		
	40			
	50			
H Gehärteter Stahl, Hartguss <i>Hardened Steel, hard cast iron</i> Acciaio temprato, ghisa conchigliata	10		Zähigkeit Toughness / Tenacità Verschleißbeständigkeit / Wear resistance / Resistenza all'usura Vorschub Feed rate / Avanzamento Schnittgeschwindigkeit Cutting speed / Velocità di taglio	Zähigkeit Toughness / Tenacità Verschleißbeständigkeit / Wear resistance / Resistenza all'usura Vorschub Feed rate / Avanzamento Schnittgeschwindigkeit Cutting speed / Velocità di taglio
	20			
	30			
	40			
	50			

Hauptanwendungsbereich / Main application area / Applicazione principale

Nebenanwendungsbereich / Secondary application area / Applicazione dsecondaria

AM35C — Sorte / Grade / Qualità
Empfohlener Anwendungsbereich / Recommended application area / Applicazione consigliata

AR26C — Sorte / Grade / Qualità
Empfohlener Anwendungsbereich / Recommended application area / Applicazione consigliata

Recommended cutting data
Parametri di taglio

Längsdrehen / Turning / Tornitura

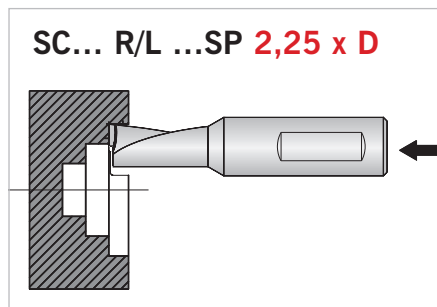

SHARK-Cut®-Ø [mm]	Spantiefe ap [mm] / Depth of cut / Profondità di passata							
	0,5	1	1,5	2	2,5	3	3,5	4
Vorschub f [mm/U] / Feed rate / Velocità di avanzamento								
SC04	0,10	0,10	0,08	0,05	-	-	-	-
SC05	0,10	0,10	0,09	0,06	0,04	-	-	-
SC06	0,10	0,10	0,10	0,08	0,06	0,04	-	-
SC07	0,10	0,10	0,10	0,10	0,08	0,06	0,04	-
SC08	0,10	0,10	0,10	0,10	0,10	0,08	0,06	0,04

Längsdrehen / Turning / Tornitura

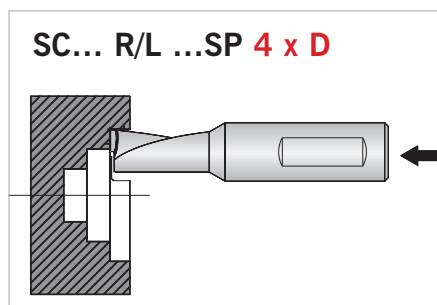

SHARK-Cut®-Ø [mm]	Spantiefe ap [mm] / Depth of cut / Profondità di passata					
	0,5	1	1,5	2	2,5	3
Vorschub f [mm/U] / Feed rate / Velocità di avanzamento						
SC04	0,10	0,08	0,050	-	-	-
SC05	0,10	0,09	0,060	0,040	-	-
SC06	0,10	0,09	0,060	0,040	-	-
SC07	0,10	0,10	0,080	0,060	0,040	-
SC08	0,10	0,10	0,085	0,075	0,055	0,040

Plandrehen / Facing / Sfacciatura

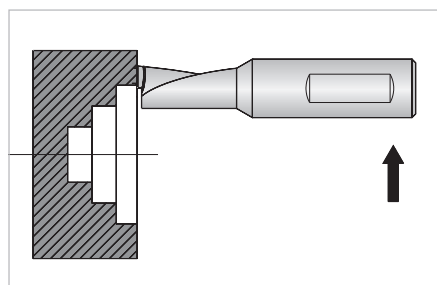

SHARK-Cut®-Ø [mm]	SC...R/L...SP (2,25 x D)		SC...R/L...SP-ALU (4 x D)	
	ap [mm]	f [mm/U]	ap [mm]	f [mm/U]
SC04	0,7	0,07	0,7	0,05
SC05	0,7	0,07	0,7	0,05
SC06	0,7	0,07	0,7	0,05
SC07	1,0	0,08	1,0	0,06
SC08	1,0	0,08	1,0	0,06

Bohren / Drilling / Foratura

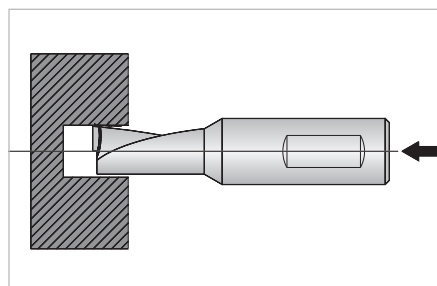

SHARK-Cut®-Ø [mm]	SC...R/L...SP (2,25 x D)	SC...R/L...SP-ALU (4 x D)
	f [mm/U]	f [mm/U]
SC04	0,005 - 0,030	0,005 - 0,020
SC05	0,005 - 0,030	0,005 - 0,020
SC06	0,005 - 0,030	0,005 - 0,020
SC07	0,005 - 0,035	0,005 - 0,025
SC08	0,005 - 0,040	0,005 - 0,030



Längsdrehen / Turning / Tornitura

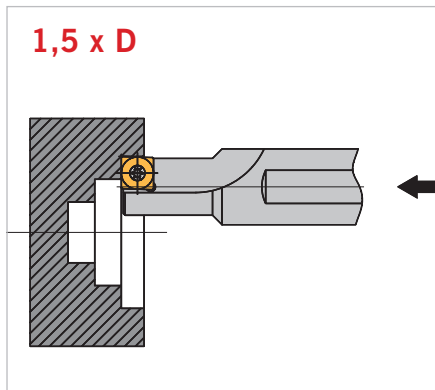

SHARK-Cut®-Ø [mm]	Spantiefe ap [mm] / Depth of cut / Profondità di passata											
	1	2	3	4	5	6	7	8	9	10	12	14
Vorschub f [mm/U] / Feed rate / Velocità di avanzamento												
SC08...(LP...04)	0,12	0,11	0,10	0,07	-	-	-	-	-	-	-	-
SC10...(LP...05)	0,15	0,15	0,12	0,10	0,09	-	-	-	-	-	-	-
SC12...(LP...06)	0,16	0,16	0,15	0,13	0,12	0,10	-	-	-	-	-	-
SC14...(LP...07)	0,18	0,18	0,18	0,15	0,13	0,11	-	-	-	-	-	-
SC16...(LP...08)	0,20	0,20	0,20	0,19	0,17	0,15	0,14	0,12	-	-	-	-
SC18...(LP...09)	0,21	0,21	0,21	0,21	0,19	0,17	0,16	0,14	-	-	-	-
SC20...(LP...10)	0,22	0,22	0,22	0,22	0,22	0,21	0,19	0,17	0,16	0,15	-	-
SC25...(LP...13)	0,26	0,26	0,26	0,26	0,26	0,26	0,25	0,23	0,22	0,20	0,16	-
SC32...(LP...17)	0,30	0,30	0,30	0,30	0,30	0,30	0,30	0,28	0,27	0,25	0,17	0,18

Längsdrehen / Turning / Tornitura

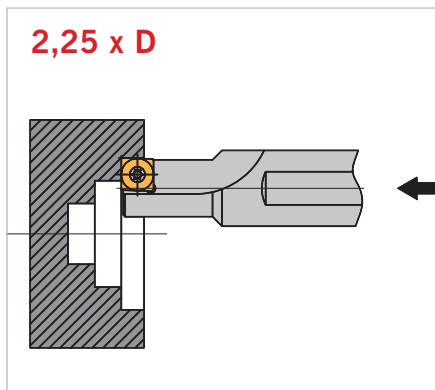

SHARK-Cut®-Ø [mm]	Spantiefe ap [mm] / Depth of cut / Profondità di passata						
	1	2	2,5	3	3,5	4	5
Vorschub f [mm/U] / Feed rate / Velocità di avanzamento							
SC08...(LP...04)	0,12	0,09	0,07	-	-	-	-
SC10...(LP...05)	0,15	0,12	0,10	0,09	-	-	-
SC12...(LP...06)	0,16	0,16	0,13	0,12	0,10	-	-
SC14...(LP...07)	0,18	0,18	0,16	0,14	0,11	-	-
SC16...(LP...08)	0,20	0,20	0,18	0,16	0,14	0,12	-
SC18...(LP...09)	0,21	0,21	0,20	0,18	0,16	0,14	-
SC20...(LP...10)	0,22	0,22	0,22	0,21	0,19	0,17	0,12
SC25...(LP...13)	0,28	0,28	0,28	0,28	0,25	0,23	0,20
SC32...(LP...17)	0,30	0,30	0,30	0,30	0,28	0,28	0,25

Längsdrehen / Turning / Tornitura

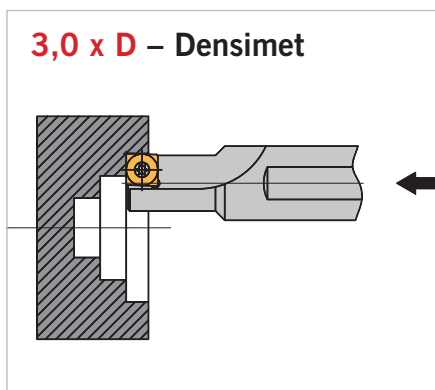

SHARK-Cut®-Ø [mm]	Spantiefe ap [mm] / Depth of cut / Profondità di passata						
	1	2	2,5	3	3,5	4	5
Vorschub f [mm/U] / Feed rate / Velocità di avanzamento							
SC08...(LP...04)	0,12	0,09	0,07	-	-	-	-
SC10...(LP...05)	0,13	0,11	0,09	0,07	-	-	-
SC12...(LP...06)	0,15	0,13	0,12	0,11	0,10	-	-
SC14...(LP...07)	0,16	0,16	0,15	0,13	0,11	-	-
SC16...(LP...08)	0,18	0,18	0,17	0,15	0,13	0,12	-
SC18...(LP...09)	0,20	0,20	0,18	0,17	0,15	0,14	-
SC20...(LP...10)	0,22	0,22	0,22	0,21	0,19	0,16	0,14
SC25...(LP...13)	0,25	0,25	0,25	0,25	0,23	0,22	0,18
SC32...(LP...17)	0,28	0,28	0,28	0,28	0,28	0,28	0,22

Längsdrehen / Turning / Tornitura

Werkstoff Material Materiale	Elastizitätsmodul [kg/mm²] Modulus of elasticity Modulo di elasticità	Dichte [g/cm³] Thickness Peso specifico
Densimet	360	17,50
Stahl	210	7,85

Höchste Präzision bei hervorragender Oberflächengüte und gesteigerten Standzeiten werden durch hohes Elastizitätsmodul und hohe Dichte erreicht, da diese besonders schwingungsdämpfend wirken.

Absolute precision, excellent surface quality and improved tool life have been achieved as a result of the high modulus of elasticity and density since these particularly reduce vibrations.

Assoluta precisione, eccellente finitura superficiale ed incremento delle vita utensile sono ottenute da un materiale antivibrante risultato di un abbinamento tra un elevato modulo di elasticità ed un elevato peso specifico.

Recommended cutting data
Parametri di taglio

Plandrehen / Facing / Sfacciatura

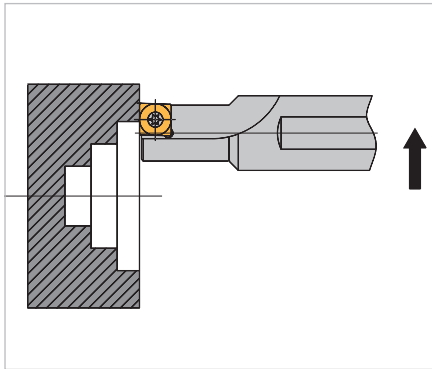

SHARK-Cut®-Ø [mm]	1,5 x D		2,25 x D		3 x D – Densimet	
	ap [mm]	f [mm/U]	ap [mm]	f [mm/U]	ap [mm]	f [mm/U]
SC08...(LP...04)	2,00	0,10	1,50	0,07	1,00	0,10
SC10...(LP...05)	2,50	0,12	2,00	0,12	1,20	0,12
SC12...(LP...06)	3,00	0,15	2,50	0,14	1,50	0,15
SC14...(LP...07)	3,50	0,16	3,00	0,15	1,70	0,16
SC16...(LP...08)	4,00	0,17	3,50	0,16	2,00	0,17
SC18...(LP...09)	5,00	0,18	3,50	0,17	2,30	0,18
SC20...(LP...10)	5,00	0,20	4,00	0,18	2,50	0,20
SC25...(LP...13)	6,00	0,24	5,00	0,22	3,00	0,24
SC32...(LP...17)	8,00	0,27	6,00	0,26	3,50	0,27

Bohren / Drilling / Foratura

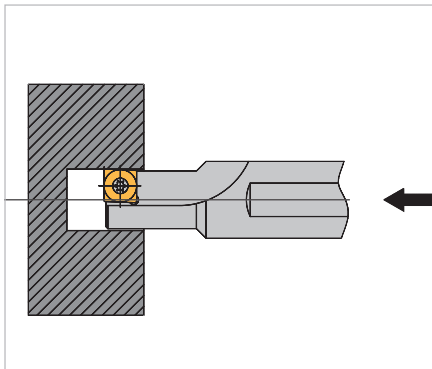

SHARK-Cut®-Ø [mm]	1,5 - 2,25 x D	3 x D – Densimet
	f [mm/U]	f [mm/U]
SC08...(LP...04)	0,01 - 0,04	0,01 - 0,02
SC10...(LP...05)	0,01 - 0,05	0,01 - 0,03
SC12...(LP...06)	0,01 - 0,05	0,01 - 0,04
SC14...(LP...07)	0,01 - 0,07	0,01 - 0,05
SC16...(LP...08)	0,02 - 0,08	0,02 - 0,06
SC18...(LP...09)	0,03 - 0,09	0,03 - 0,07
SC20...(LP...10)	0,03 - 0,10	0,03 - 0,08
SC25...(LP...13)	0,03 - 0,12	0,04 - 0,09
SC32...(LP...17)	0,05 - 0,15	0,05 - 0,11

Recommended cutting data
Parametri di taglio

Aufbohren / Boring / Barenatura

2-schneidig

2 flute
2 taglienti

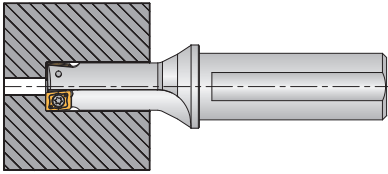

SHARK-Cut® Rebore- Ø [mm]	Spantiefe ap [mm] / Depth of cut / Profondità di passata													
	1	2	3	4	5	6	7	8	9	10	12	14		
Vorschub f [mm/U] / Feed rate / Velocità di avanzamento														
12 - 15 (LP..04)	0,25	0,22	0,20	0,16	-	-	-	-	-	-	-	-	-	-
16 - 17,5 (LP..05)	0,30	0,30	0,28	0,24	0,20	-	-	-	-	-	-	-	-	-
18 - 19 (LP..06)	0,34	0,34	0,34	0,30	0,25	0,20	-	-	-	-	-	-	-	-
20 - 23 (LP..07)	0,36	0,36	0,36	0,33	0,30	0,26	0,22	-	-	-	-	-	-	-
24 - 25(LP..08)	0,42	0,42	0,42	0,42	0,38	0,34	0,30	0,25	-	-	-	-	-	-
26 - 28 (LP..09)	0,44	0,44	0,44	0,44	0,44	0,40	0,35	0,32	0,28	-	-	-	-	-
29 - 24(LP..10)	0,48	0,48	0,48	0,48	0,48	0,45	0,40	0,36	0,32	0,30	-	-	-	-
35 - 44 (LP..13)	0,52	0,52	0,52	0,52	0,52	0,52	0,50	0,47	0,43	0,38	0,30	-	-	-
45 - 50 (LP..17)	0,60	0,60	0,60	0,60	0,60	0,60	0,60	0,60	0,55	0,50	0,42	0,35	-	-

Aufbohren / Boring / Barenatura

3-schneidig

3 flute
3 taglienti

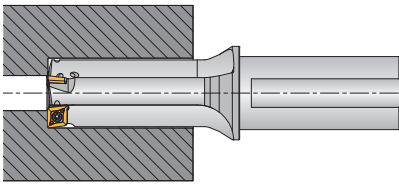

SHARK-Cut® Rebore- Ø [mm]	Spantiefe ap [mm] / Depth of cut / Profondità di passata													
	1	2	3	4	5	6	7	8	9	10	12	14		
Vorschub f [mm/U] / Feed rate / Velocità di avanzamento														
24 - 25 (LP..06)	0,51	0,51	0,51	0,45	0,38	0,30	-	-	-	-	-	-	-	-
26 - 28 (LP..07)	0,54	0,54	0,54	0,49	0,45	0,39	0,33	-	-	-	-	-	-	-
29 - 34 (LP..08)	0,63	0,63	0,63	0,63	0,57	0,51	0,45	0,38	-	-	-	-	-	-
35 - 40 (LP..09)	0,66	0,66	0,66	0,66	0,66	0,60	0,53	0,48	0,42	-	-	-	-	-
41 - 47 (LP..10)	0,72	0,72	0,72	0,72	0,72	0,68	0,60	0,54	0,48	0,45	-	-	-	-
48 - 50 (LP..13)	0,78	0,78	0,78	0,78	0,78	0,78	0,75	0,70	0,65	0,57	0,45	-	-	-

Maximale Bohrtiefen / Maximum drilling depth / Massima profondità di foratura

Maximale Bohrtiefen / Maximum drilling depth / Massima profondità di foratura					
SHARK-Cut®-Ø [mm]	Mini (2,25 x D) [mm]	Mini ALU (4 x D) [mm]	1,5 x D [mm]	2,25 x D [mm]	3 x D [mm]
4	9,00	16	-	-	-
5	11,25	20	-	-	-
6	13,50	24	-	-	-
7	15,75	28	-	-	-
8	18,00	32	12	18,0	24
10	-	-	15	22,0	30
12	-	-	18	27,0	36
14	-	-	21	31,5	42
16	-	-	24	36,0	48
18	-	-	27	40,5	54
20	-	-	30	45,0	60
25	-	-	38	56,0	75
32	-	-	48	72,0	96

Bohren aus der Mitte / Drilling off centre / Foratura fuori centro

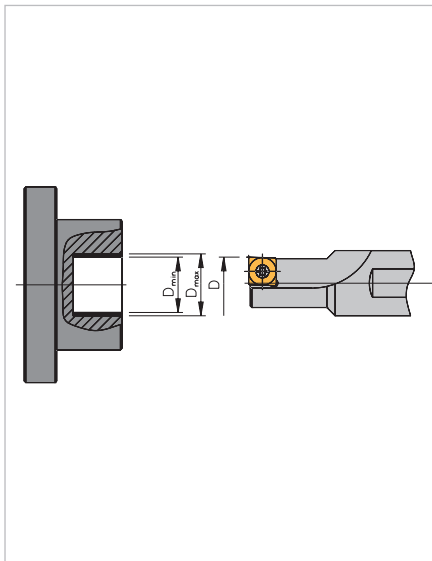

Werkzeugtyp Type of tool Tipo di utensile	Werkzeug-Nennendurchmesser Nominal tool diameter Diametro Nominale utensile	Werkstück-Bohrdurchmesser Drilling diameter Diametri ottenibili	
		D [mm]	D _{min} [mm]
SC 04 R/L-...SP...(Mini)	4	3,90	4,2
SC 05 R/L-...SP...(Mini)	5	4,90	5,2
SC 06 R/L-...SP...(Mini)	6	5,90	6,2
SC 07 R/L-...SP...(Mini)	7	6,90	7,2
SC 08 R/L-...SP...(Mini)	8	7,90	8,2
SC 08 R/L-...04	8	7,85	8,3
SC 10 R/L-...05	10	9,85	10,5
SC 12 R/L-...06	12	11,85	12,5
SC 14 R/L-...07	14	13,85	14,5
SC 16 R/L-...08	16	15,85	16,5
SC 18 R/L-...09	18	17,85	18,5
SC 20 R/L-...10	20	19,80	20,5
SC 25 R/L-...13	25	24,80	25,8
SC 32 R/L-...17	32	31,80	33,0

Durch die speziell entwickelte und aufeinander abgestimmte Ausführung von Werkzeug und Wendeschneidplatte ist es möglich außer Mitte zu bohren. Es können somit Abweichungen zum Werkzeugdurchmesser erreicht werden.

Because of the special design of the holder and indexable inserts, it is possible to drill off centre.

Grazie allo speciale profilo dell'inserto e utensile è possibile forare fuori centro.

Coolant-Booster / Coolant-Booster / Ugelli Booster

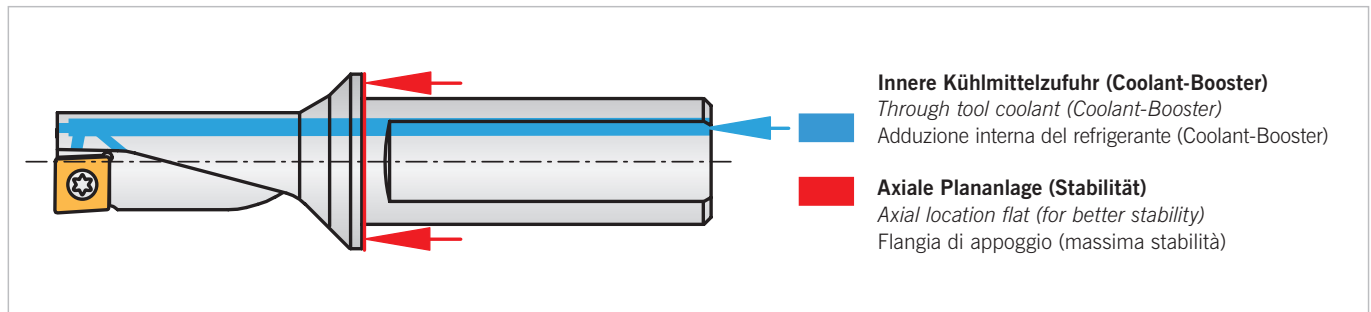

Kühlmitteldruck

Als innovative Detaillösung bietet der SHARK-Cut® eine spezielle Kühlmittelzufuhr zur besseren Ausbringung der Späne aus der Bohrung. Ein eigener, rückwärtsgerichteter Kühlmittelstrahl sorgt für einen verbesserten Spänetransport. Der Kühlmitteldruck muss dafür, unabhängig vom Durchmesser, ca. 1,5–3 bar (optimal 5–7 bar) betragen.

Coolant pressure

The SHARK-Cut® tool offer a unique detail when it comes to swarf evacuation. A "return" (pointing back up the flute) coolant channel ensures optimum swarf evacuation, therefore the coolant pressure, no matter the diameter, must be 1.5–3 bar (optimum 5–7 bar).

Pressione del refrigerante

Lo SHARK-Cut® offre un dettaglio unico per l'aiuto nell'evacuazione truciolo. Un ugello orientato in direzioni di uscita del foro aiuta il truciolo ad incanalarsi e ad essere espulso. La pressione suggerita, indipendente dal diametro deve essere di almeno 1,5–3 bar (optimale 5–7 bar).

Achsversatz der Maschine / Displacement of the machine / Montaggio sulla macchina utensile

4

<p>Situation / Situation / Condizione</p> <p>Versatz in X-Richtung Displacement in X-direction Collisione lungo l'asse X</p>		<p>Lösung / Solution / Soluzione</p> <p>Werkzeugkorrektur anpassen Correct tool positioning Correggere posizione</p>
<p>Situation / Situation / Condizione</p> <p>Winkelfehler Angle error Orientamento errato</p>		<p>Lösung / Solution / Soluzione</p> <p>Revolver und/oder Spindelstock ausrichten Turret and/or spindle adjustment Registrazione torretta e/o mandrino</p>
<p>Situation / Situation / Condizione</p> <p>Revolver-Positionierfehler Turret positioning error Posizionamento della torretta errato</p>		<p>Lösung / Solution / Soluzione</p> <p>Revolverscheibe ausrichten (Y-Achse) Adjust turret plate (Y-axis) Registrazione piano torretta (Asse Y)</p>

WIPER-Geometrie / WIPER-Geometry / WIPER-Geometria
Funktionsprinzip (Nutzen) / Information / Obiettivi

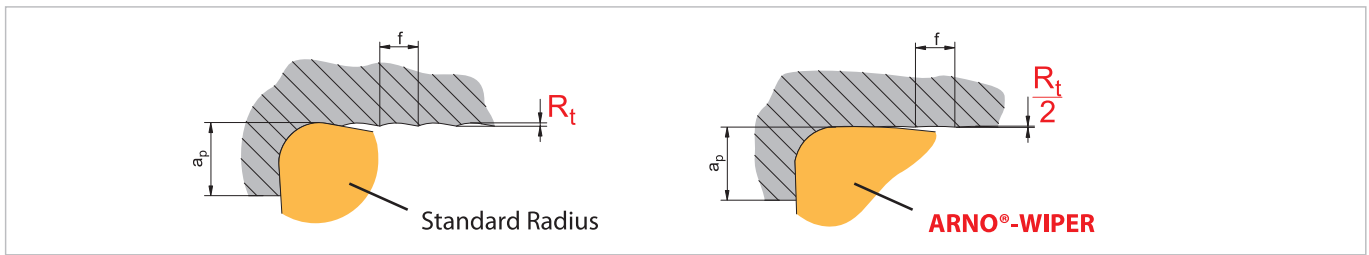

Bessere Oberfläche

Bei gleichem Vorschub erreicht die Wende-schneidplatte mit WIPER-Schneide einen um das Vielfache besseren R_a -Wert gegenüber einer herkömmlichen Wende-schneidplatte.

Better surface

At the same feed rate the WIPER insert achieves a much better R_a -value against a conventional insert.

Migliore finitura superficiale

Con i medesimi avanzamenti dell'inserto normale, la geometria WIPER assicura un migliore valore R_a .

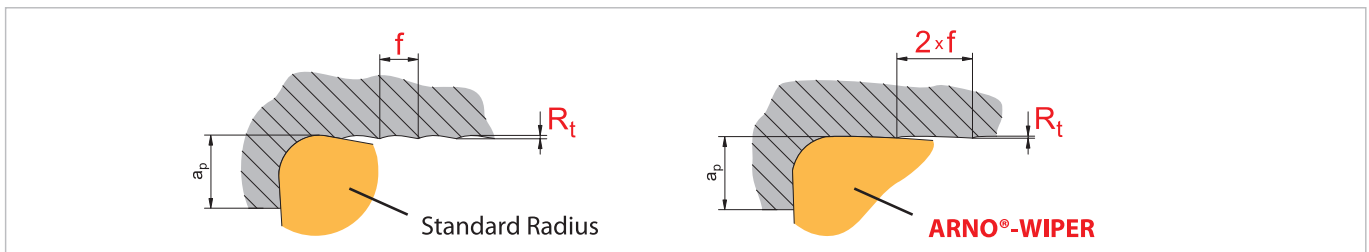

Geringere Bearbeitungszeit

Soll der gleiche R_a -Wert erreicht werden wie mit einer Standard-Wende-schneidplatte, so kann mit der Schneidplatte mit WIPER-Schneide der doppelte Vorschub gefahren werden (= geringere Stückzeiten!).

Reduced machine time

If the required R_a -value is achieved with a standard insert, the insert can be applied using up to twice the feed rate and thereby reducing machine time.

Riduzione tempo ciclo

La geometria WIPER permette avanzamenti anche doppi rispetto agli inserti a raggio standard assicurando pari rugosità superficiale. Questa caratteristica arriva a dimezzare i tempi ciclo, specialmente in operazioni di barenatura.

Bearbeitung über Mitte / Machining over centre / Lavorazione fuori asse

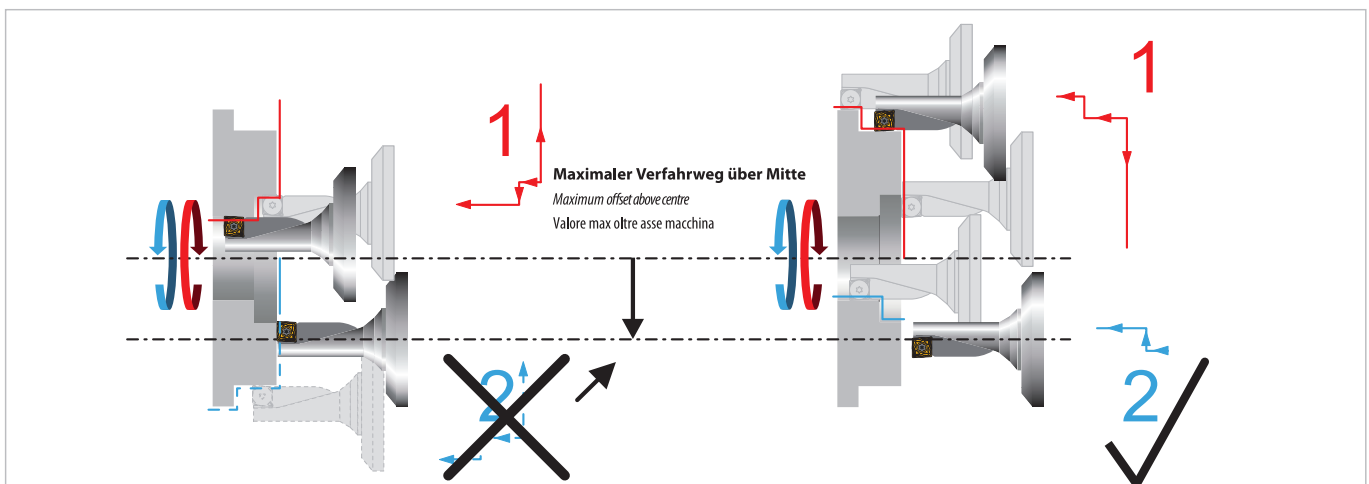

4

Situation / Situation / Condizione

Bei nicht ausreichendem Verfahrweg der Maschine über die Mittel-achse ist der Außendurchmesser nicht mit dem selben Werkzeug bearbeitbar.

At not adequate travel of the machine over the centre the outside diameter can not be machined with the same tool.

Nel caso di corse ridotte delle macchine utensili i diametri esterni possono non essere lavorabili con il medesimo utensile.

Lösung / Solution / Soluzione

Verwendung eines rechten SHARK-Cut® Werkzeuges.

Using a right hand SHARK-Cut® tool.

Utilizzare un utensile SHARK-Cut® destro.

Durchgangsbohrung / Through hole drilling / Foratura passante

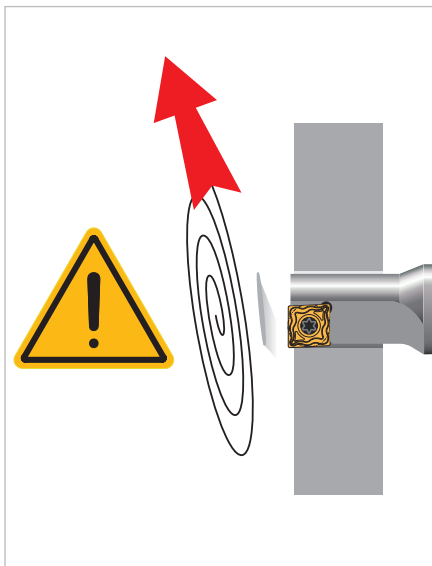

Hinweis

Bei feststehendem Werkzeug und rotierendem Werkstück fällt bei Durchgangsbohrungen eine scharfkantige Ronde ab. Bitte Sicherheitsvorkehrungen treffen.

Der Kühlmitteldruck sollte für SHARK-Cut® 2,25 x D ca. 5–7 bar und für SHARK-Cut® 1,5 x D ca. 1,5–3 bar betragen. Ist der notwendige Kühlmitteldruck maschinenseitig nicht vorhanden, kann es von Vorteil sein, den Bohrvorgang kurz zu unterbrechen, um die Bohrung zu entleeren.

Information

When through hole drilling with stationary tool and rotating component a sharp disc is produced, please ensure adequate safety precautions.

The coolant pressure for a 1.5 x D SHARK-Cut® should be minimum 1.5–3 bar, for 2.25 x D drill depth 5–7 bar is required. If the necessary coolant pressure is not available, it could be beneficial to interrupt the cutting briefly in order to clear the hole.

Accorgimenti

In operazioni di foratura passante con utensile fisso, un disco affilato risulta a fine operazione, assicurare adeguate protezioni.

La pressione del refrigerante per un utensile SHARK-Cut® 1,5 x D deve essere minimo 1,5–3 bar, mentre per la versione 2,25 x D è suggerito un minimo di 5–7 bar. Nei casi in cui la pressione del refrigerante non fosse sufficiente è suggerito prevedere una lavorazione con interruzioni per assicurare una giusta evacuazione truciolo.

Bohrtiefen bis 3 x D / Deep bores up to 3 x D / Per forature fino a 3 x D

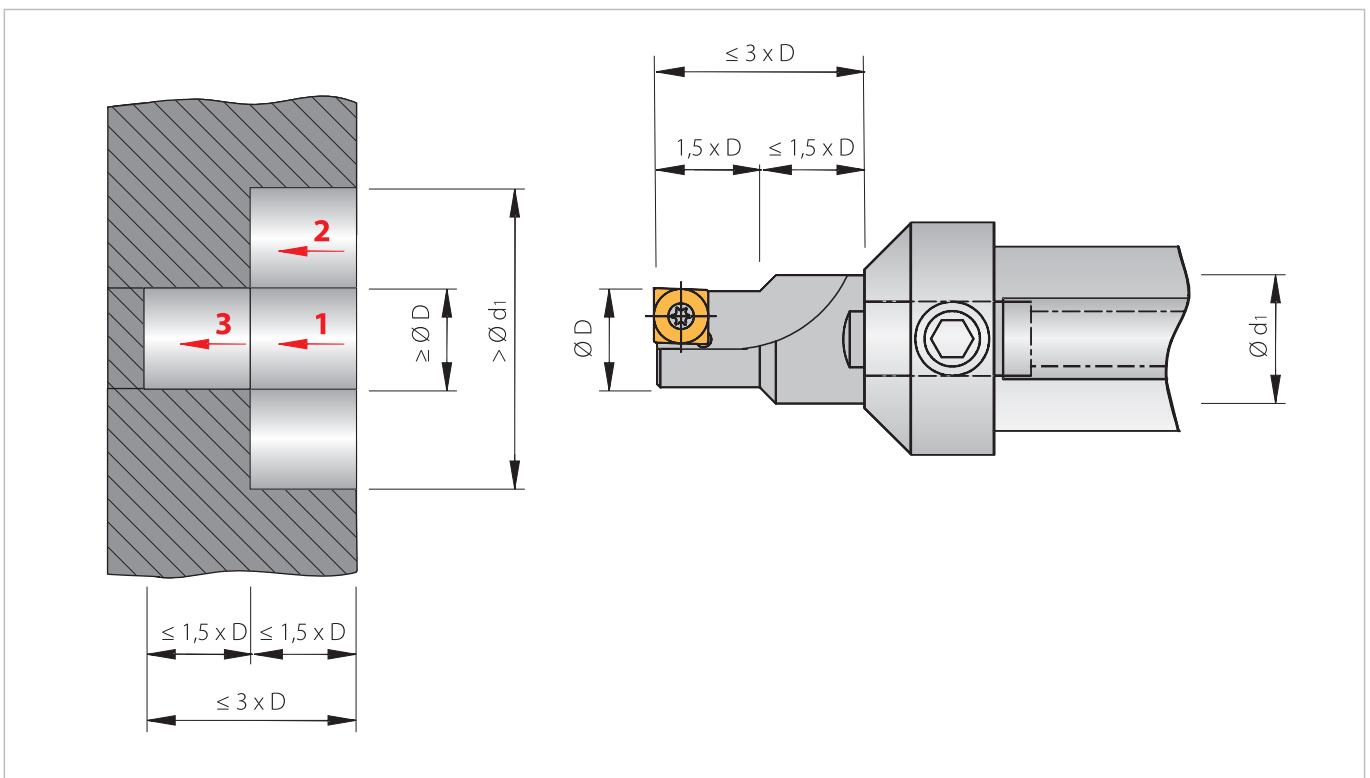

Mit SHARK-Cut® Werkzeugen SC..1,5 x D können bei entsprechender Werkstückkontur, Bohrtiefen bis zum Dreifachen des Nenn-durchmessers erreicht werden (siehe Bild). Es ist dabei auf die Arbeitsabfolge 1, 2 und 3 zu achten. Für Werkzeuge mit dem Durchmesser 8 mm werden rechte und linke Wendeschneidplatten benötigt. Für Werkzeuge mit Durchmesser 10 bis 32 mm kommen neutrale Wendeschneidplatten zum Einsatz.

With the SHARK-Cut® tools SC..1.5 x D it is possible to drill up to three times the diameter (see picture). However please note working order 1, 2 and 3. For holders with diameter 8 mm use inserts with right and left chip breakers. For holders with diameter 10 to 32 mm use neutral inserts.

Con corpo utensile SC..1,5 x D è possibile forare fino a 3 x D a condizione che la forma del foro corrisponda alla figura. Prestare attenzione all'ordine 1, 2 e 3. Per utensili diametro 8 mm prestare attenzione agli inserti che hanno versione Destra e Sinistra. Per utensili superiori a 10 a 32 mm di diametro gli inserti sono neutri.

Werkzeug zum Aufbohren mit 2 bzw. 3 Schneiden.

Tools for boring with 2 or 3 edges.

Utensile per barenatura con 2 o 3 inserti.

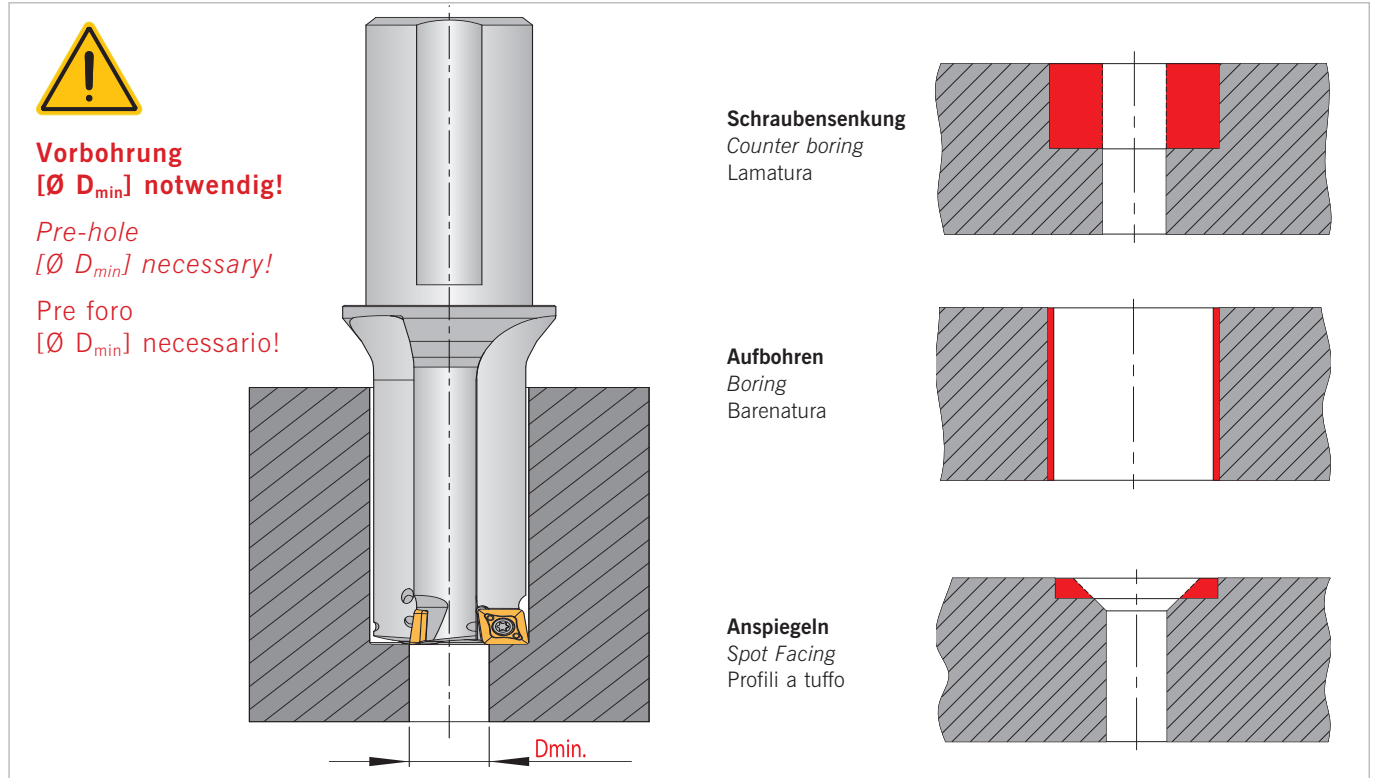

Formeln / Formulas / Formule

Schnittgeschwindigkeit

Cutting Speed
Velocità di taglio

$$V_c = \frac{\pi \cdot D \cdot n}{1000}$$

Drehzahl

Revolution per minute
Numero di giri al minuto

$$n = \frac{V_c \cdot 1000}{\pi \cdot D}$$

Zeitspanvolumen

Chip removal rate
Volume truciolo

$$Q = V_c \cdot a_p \cdot f_n$$

D	Durchmesser Diameter Diametro	[mm]	f_n	Vorschub pro Umdrehung Feed rate per revolution Avanzamento al giro	[mm/U]	n	Spindeldrehzahl Spindel revolution Numero di giri	[U/min]
V_c	Schnittgeschwindigkeit Cutting speed Velocità di taglio	[m/min]	a_p	Schnitttiefe Depth of cut Profondità di passata	[mm]	Q	Zeitspanvolumen Chip removal rate Volume truciolo	[cm ³ /min]



Anwendungsproblem / Type of problem / Tipo di problema								Abhilfe Corrective measures Soluzioni possibili	Kriterium / Criteria / Criterio
Ausbrüche Edge chipping Scheggiatura inserto	Aufbauschneide Built-up edge Tagliente di riporto	Freiflächenverschleiß Wear in clearance face Labbro di usura	Plastische Verformung Plastic deformation Deformazione plastica	Vibrationen Vibrations Vibrazioni	Oberflächengüte Surface finish Finitura superficiale	Span zu lang Chip too long Truciolo lungo	Span zu kurz Chip too short Truciolo troppo corto		
	↑	↓	↓	↓	↑	↓		Schnittgeschwindigkeit Cutting speed Velocità di taglio	Schnittwerte / Cutting values / Parametri di taglio
↓		~	↓	↑	↓	↑	↓	Vorschub Feed Avanzamento	
↑		↑	↑	↓	↑			Eckenradius Corner radius Raggio di punta	Wende- schneidplatten / Insert selection / Scelta inserto
↓		↑	↑					Schneidstoff Cutting material Materiale da taglio	
~				~	~			Spannung Werkzeug Tool clamping Bloccaggio utensile	Allgemeine Kriterien / General criteria / Accorgimenti generali
~				~	~			Spannung Werkstück Workpiece clamping Bloccaggio pezzo	
~				~	↓			Auskragung Overhang Sporgenza	
~		~		~	~			Spitzenhöhe Tip height Altezza tagliente	
	•	•	•		•	•		Kühlschmierstoff Cooling lubricant Lubro-refrigerante	

↑ erhöhen, vergrößern - großer Einfluss
 increase, bigger effect
 aumentare notevolmente i valori

↓ senken, verkleinern - großer Einfluss
 increase, bigger effect
 aumentare notevolmente i valori

↑ erhöhen, vergrößern - kleiner Einfluss
 increase, smaller effect
 aumentare leggermente i valori

↓ senken, verkleinern - kleiner Einfluss
 reduce, smaller effect
 diminuire notevolmente i valori

• verwenden
 apply
 utilizzare

~ kontrollieren, optimieren
 check, optimize
 controllare, ottimizzare